



SIDE ROTARY ASSEMBLIES

KUBOTA M105X/S
CAB / WOC

Current as of 07/12/2010

PARTS LISTING WITH
MOUNTING AND OPERATING
INSTRUCTIONS

Tiger Corporation
3301 N. Louise Ave.
Sioux Falls, SD 57107
1-800-843-6849
1-605-336-7900
www.tiger-mowers.com

06070001

TO THE OWNER / OPERATOR / DEALER

All implements with moving parts are potentially hazardous. There is no substitute for a cautious, safe-minded operator who recognizes the potential hazards and follows reasonable safety practices. The manufacturer has designed this implement to be used with all its safety equipment properly attached to minimize the chance of accidents.

BEFORE YOU START!! Read the safety messages on the implement and shown in this manual. Observe the rules of safety and use common sense!

READ AND UNDERSTAND THIS MANUAL! Non-English speaking operators will need to GET THE MANUAL TRANSLATED as needed!



DANGER

FAILING TO FOLLOW SAFETY MESSAGES AND OPERATING INSTRUCTIONS CAN CAUSE SERIOUS BODILY INJURY OR EVEN DEATH TO OPERATOR AND OTHERS IN THE AREA.

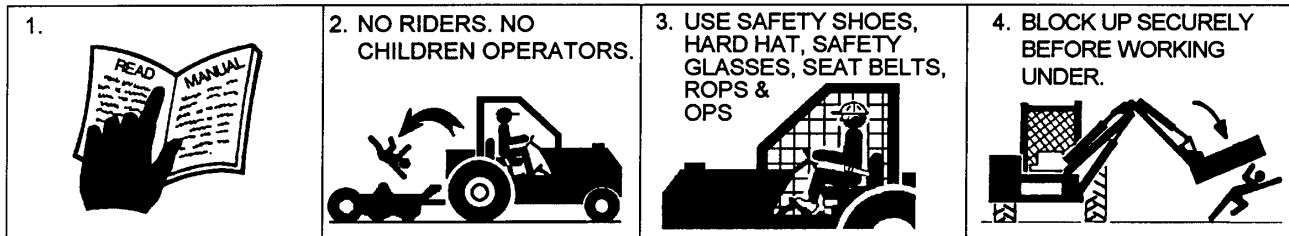

1. Study and understand Operator's Manuals, Safety Decals, and Instructional Decals for tractor and implement to prevent misuse, abuse, and accidents. Practice before operating in a confined area or near passersby.

● Learn how to stop engine suddenly in an emergency. Be alert for passersby and especially children

2. Allow no children on or near folding mower or tractor. Allow no riders on tractor or implement. Falling off may cause serious injury or death from being run over by tractor or mower or contact with rotating blades.

3. Operate only with tractor having Roll-Over Protective Structure (ROPS) and with seat belt securely fastened to prevent injury and possible death from falling off or tractor overturn.

● Personal Protective Equipment such as Hard Hat, Safety Glasses, Safety Shoes, & Ear Plugs are recommended.

4. Block up or support raised machine and all lifted components securely before putting hands or feet under or working underneath any lifted component to prevent crushing injury or death from sudden dropping or inadvertent operation of controls. Make certain area is clear before lowering or folding

5. Before transporting, put Lift Lever in detent or full-lift position. Install Transport Safety Devices securely on folding mowers. Put Booms securely in Transport Rest.

● Folding and Boom Mowers have raised center of gravity. Slow down when turning and on hillsides.

6. Make certain that SMV sign, warning lights, and reflectors are clearly visible. Follow local traffic codes.

7. Never operate with Cutting Head or Folding Section raised if passersby, bystanders, or traffic are in the area to reduce possibility of injury or death from objects thrown by Blades under Guards or mower structure.

8. Before dismounting, secure implement in transport position or lower to ground.

● Put tractor in park or set brake, disengage PTO, stop engine, remove key, and wait until noise of rotation has ceased to prevent crushing by entanglement in rotating parts which could cause injury or death.

● Never mount or dismount a moving vehicle. Crushing from rollover may cause serious injury or death.

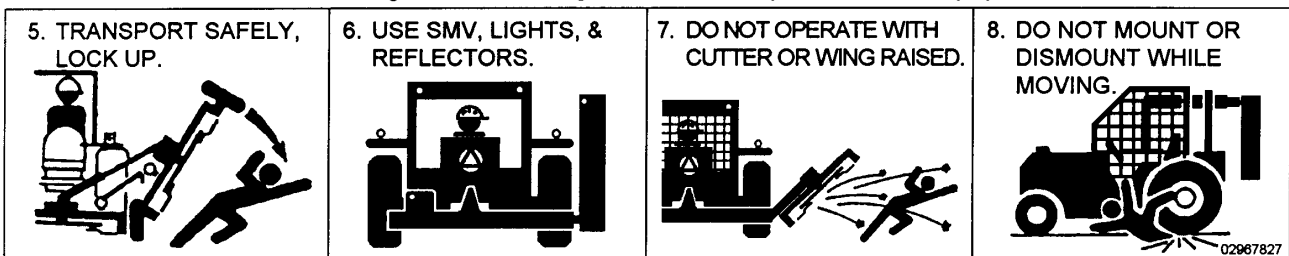

02967827

Warranty Information: Read and understand the complete Warranty Statement found in this manual. Fill out the Warranty Registration form in full and return it within 90 days. Make certain the Serial Number of the machine is recorded on the Warranty Card, and form that you retain.

FORWARD

This manual contains information about many features of the Tiger mowing and roadside maintenance equipment. Some of these include: Safety precautions, Assembly instructions, Operations, Maintenance and Parts. This manual will also assist you in the proper break-in, daily care, and troubleshooting of your new mower.

We recommend that you read carefully the entire manual before operating the unit. Also, time spent in becoming fully acquainted with its performance features, adjustments, and maintenance schedules will be repaid in a long and satisfactory life of the equipment.

Troubleshooting - Please, before you call, help us to help you!

Please look at the equipment to observe what is happening, then:

- Classify the problem
 - Hydraulic, electrical or mechanical - Read the trouble shooting section
 - Tractor or Truck chassis - Contact vehicle dealer

- If unable to correct the problem yourself, contact your local Tiger Dealer after gathering:
 - Machine model _____
 - Serial number _____
 - Dealer name _____
 - Detailed information about the problem including results of troubleshooting

Attention Owner / Operator / Dealer: It is your obligation to read, and understand, the warranty information section located at the back of this manual denoting that the purchaser understands the safety issues relating to this machine and has received and will read a copy of this manual.

If at any time, you have a service problem with your Tiger mower, Contact your local dealer for service and parts needed.

MANUFACTURED BY:

Tiger Corporation

3301 N. Louise Ave.

Sioux Falls, SD 57107

1-800-843-6849

1-605-336-7900

www.tiger-mowers.com

DISTRIBUTED BY:

1-_____-_____-_____

1-_____-_____-_____

TABLE OF CONTENTS

SAFETY _____	1-1
Safety Information_____	1-2
ASSEMBLY / MOUNTING SECTION _____	2-1
OPERATION SECTION _____	3-1
MAINTENANCE SECTION _____	4-1
PARTS SECTION _____	5-1
Parts Ordering Guide_____	5-2
Parts Table of Contents_____	5-3
Common Parts Section _____	6-1
WARRANTY INFORMATION _____	7-1



1012

This symbol means:

CAUTION – YOUR SAFETY IS AT RISK!

When you see this symbol, read and follow the associated instructions carefully or personal injury or damage may result.

Tiger is a registered trademark.



SAFETY SECTION

SAFETY

SAFETY

General Safety Instructions and Practices

A safe and careful operator is the best operator. Safety is of primary importance to the manufacturer and should be to the owner / operator. Most accidents can be avoided by being aware of your equipment, your surroundings, and observing certain precautions. The first section of this manual includes a list of Safety Messages that, if followed, will help protect the operator and bystanders from injury or death. Read and understand these Safety Messages before assembling, operating or servicing this mower. This equipment should only be operated by those persons who have read the Manual, who are responsible and trained, and who know how to do so safely and responsibly.



The Safety Alert Symbol combined with a Signal Word, as seen below, is used throughout this manual and on decals which are attached to the equipment. The Safety Alert Symbol means: “**ATTENTION! BECOME ALERT! YOUR SAFETY IS INVOLVED!**” The symbol and signal word are intended to warn the owner / operator of impending hazards and the degree of possible injury when operating this equipment.

Practice all usual and customary safe working precautions and above all -- remember safety is up to YOU! Only YOU can prevent serious injury or death from unsafe practices.

DANGER!



Indicates an imminently hazardous situation that, if not avoided, WILL result in DEATH OR VERY SERIOUS INJURY.

WARNING!



Indicates an imminently hazardous situation that, if not avoided, COULD result in DEATH OR SERIOUS INJURY.

CAUTION!



Indicates an imminently hazardous situation that, if not avoided, MAY result in MINOR INJURY.

IMPORTANT!

Identifies special instructions or procedures that, if not strictly observed, could result in damage to, or destruction of the machine, attachments or the environment.

NOTE: *Identifies points of particular interest for more efficient or convenient operation or repair.* (SG-1)

READ, UNDERSTAND, and FOLLOW the following Safety Messages. Serious injury or death may occur unless care is taken to follow the warnings and instructions stated in the Safety Messages. Always use good common sense to avoid hazards. (SG-2)

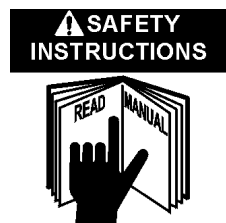

SAFETY

SAFETY

PELIGRO!



Si no lee Ingles, pida ayuda a alguien qui si lo lea para que le traduzca las medida de seguridad. (SG-3)



¡ LEA EL INSTRUCTIVO!

DANGER!



Never operate the Tractor or Implement until you have read and completely understand this Manual, the Tractor Operator's Manual, and each of the Safety Messages found in the Manual or on the Tractor and Implement. Learn how to stop the tractor engine suddenly in an emergency. Never allow inexperienced or untrained personnel too operate the Tractor and Implement without supervision. Make sure the operator has fully read and understood the manuals prior to operation. (SG-4)

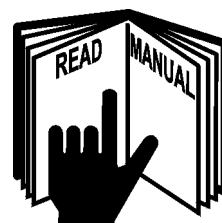

WARNING!



Always maintain the safety decals in good readable condition. If the decals are missing, damaged, or unreadable, obtain and install replacement decals immediately. (SG-5)

WARNING!



Make certain that the "Slow Moving Vehicle" (SMV) sign is installed in such a way as to be clearly visible and legible. When transporting the Equipment use the Tractor flashing warning lights and follow all local traffic regulations. (SG-6)

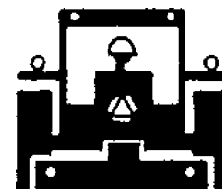

WARNING!



Operate this Equipment only with a Tractor equipped with an approved roll-over-protective system (ROPS). Always wear seat belts. Serious injury or even death could result from falling off the tractor--particularly during a turnover when the operator could be pinned under the ROPS. (SG-7)



WARNING!



Do not modify or alter this Implement. Do not permit anyone to modify or alter this Implement, any of its components or any Implement function. (SG-8)

DANGER!



BEFORE leaving the tractor seat, always engage the brake and/or set the tractor transmission in parking gear, disengage the PTO, stop the engine, remove the key, and wait for all moving parts to stop. Place the tractor shift lever into a low range or parking gear to prevent the tractor from rolling. Never dismount a Tractor that is moving or while the engine is running. Operate the Tractor controls from the tractor seat only. (SG-9)

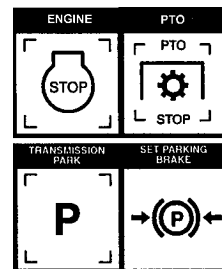

SAFETY

SAFETY

DANGER!



Never allow children or other persons to ride on the Tractor or Implement. Falling off can result in serious injury or death.

(SG-10)



DANGER!



Never allow children to operate or ride on the Tractor or Implement.

(SG-11)



WARNING!



Do not mount the Tractor while the tractor is moving. Mount the Tractor only when the Tractor and all moving parts are completely stopped.

(SG-12)



DANGER!



Start tractor only when properly seated in the Tractor seat. Starting a tractor in gear can result in injury or death. Read the Tractor operators manual for proper starting instructions. (SG-13)



DANGER!



Never work under the Implement, the framework, or any lifted component unless the Implement is securely supported or blocked up to prevent sudden or inadvertent falling which could cause serious injury or even death. (SG-14)



DANGER!



Do not operate this Equipment with hydraulic oil leaking. Oil is expensive and its presence could present a hazard. Do not check for leaks with your hand! Use a piece of heavy paper or cardboard. High-pressure oil streams from breaks in the line could penetrate the skin and cause tissue damage including gangrene. If oil does penetrate the skin, have the injury treated immediately by a physician knowledgeable and skilled in this procedure. (SG-15)

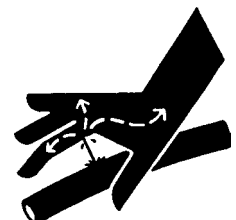

SAFETY

WARNING!



The operator and all support personnel should wear hard hats, safety shoes, safety glasses, and proper hearing protection at all times for protection from injury including injury from items thrown by the equipment. (SG-16)

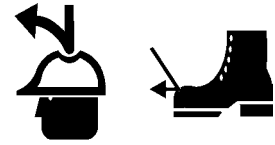

CAUTION!



PROLONGED EXPOSURE TO LOUD NOISE MAY CAUSE PERMANENT HEARING LOSS! Tractors with or without an Implement attached can often be noisy enough to cause permanent hearing loss. We recommend that you always wear hearing protection if the noise in the Operator's position exceeds 80db. Noise over 85db over an extended period of time will cause severe hearing loss. Noise over 90db adjacent to the Operator over an extended period of time will cause permanent or total hearing loss. *Note:* Hearing loss from loud noise [from tractors, chain saws, radios, and other such sources close to the ear] is cumulative over a lifetime without hope of natural recovery. (SG-17)

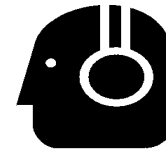

WARNING!



Transport only at safe speeds. Serious accidents and injuries can result from operating this equipment at unsafe speeds. Understand the Tractor and Implement and how it handles before transporting on streets and highways. Make sure the Tractor steering and brakes are in good condition and operate properly.



Before transporting the Tractor and Implement, determine the safe transport speeds for you and the equipment. Make sure you abide by the following rules:

1. **Test the tractor at a slow speed and increase the speed slowly. Apply the Brakes smoothly to determine the stopping characteristics of the Tractor and Implement. As you increase the speed of the Tractor the stopping distance increases. Determine the maximum safe transport speed for you and this Equipment.**
2. **Test the equipment at a slow speed in turns. Increase the speed through the turn only after you determine that it is safe to operate at a higher speed. Use extreme care and reduce your speed when turning sharply to prevent the tractor and implement from turning over.**
3. **Only transport the Tractor and Implement at the speeds that you have determined the safe and safe turning speed for you and this equipment before operating on roads or uneven equipment.**

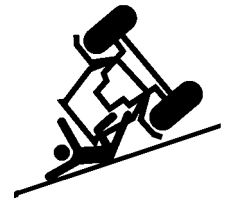

Be aware of the operating conditions. Do not operate the Tractor with weak or faulty brakes. When operating down a hill or on wet or rain slick roads, the braking distance increases: use extreme care and reduce your speed. When operating in traffic always use the Tractor's flashing warning lights and reduce your speed. Be aware of traffic around you and watch out for the other guy. (SG-19)

SAFETY

SAFETY

WARNING!



Never attempt to lubricate, adjust, or remove material from the Implement while it is in motion or while tractor engine is running. Make sure the tractor engine is off before working on the Implement.

(SG-20)

WARNING!



Periodically inspect all moving parts for wear and replace when necessary with authorized service parts. Look for loose fasteners, worn or broken parts, and leaky or loose fittings. Make sure all pins have cotter pins and washers. Serious injury may occur from not maintaining this machine in good working order. (SG-21)

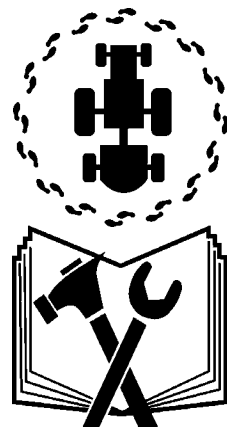

WARNING!



Always read carefully and comply fully with the manufacturers instructions when handling oil, solvents, cleansers, and any other chemical agent. (SG-22)



DANGER!



Never run the tractor engine in a closed building or without adequate ventilation. The exhaust fumes can be hazardous to your health.

(SG-23)

DANGER!



KEEP AWAY FROM ROTATING ELEMENTS to prevent entanglement and possible serious injury or death. (SG-24)



DANGER!



Never allow children to play on or around Tractor or Implement. Children can slip or fall off the Equipment and be injured or killed. Children can cause the Implement to shift or fall crushing themselves or others. (SG-25)

DANGER!



DO NOT allow any person under a folded wing unless wing is securely locked up or supported. **DO NOT** approach the Implement unless the Tractor is turned off and all motion has ceased. Never work under the frame work, or any lifted component unless the implement is securely supported or blocked up. A sudden or inadvertent fall by any of these components could cause serious injury or even death. (STI-3)



SAFETY

CAUTION!



On a fully-assembled unit, do not remove the Wing Retaining Strap until hoses are attached to the tractor and the Wing Cylinders are filled with oil. Lower the Wings slowly and carefully. Keep bystanders away during operations. (STI-5)

DANGER!



NEVER use drugs or alcohol immediately before or while operating the Tractor and Implement. Drugs and alcohol will affect an operator's alertness and coordination and therefore affect the operator's ability to operate the equipment safely. Before operating the Tractor or Implement, an operator on prescription or over-the-counter medication must consult a medical professional regarding any side effects of the medication that would hinder their ability to operate the Equipment safely. **NEVER** knowingly allow anyone to operate this equipment when their alertness or coordination is impaired. Serious injury or death to the operator or others could result if the operator is under the influence of drugs or alcohol. (SG-27)

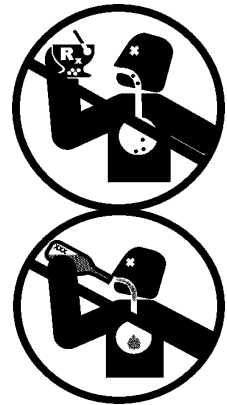

DANGER!



Operate the Tractor and/or Implement controls only while properly seated in the Tractor seat with the seat belt securely fastened around you. Inadvertent movement of the Tractor or Implement may cause serious injury or death. (SG-29)

WARNING!



Mow only in conditions where you have clear visibility in daylight or with adequate artificial lighting. Never mow in darkness or foggy conditions where you cannot clearly see at least 100 yards in front and to the sides of the tractor and mower. Make sure that you can clearly see and identify passersby, steep slopes, ditches, drop-offs, overhead obstructions, power lines, debris and foreign objects. If you are unable to clearly see this type of items discontinue mowing. (SGM-1)

DANGER!



There are obvious and hidden potential hazards in the operation of this Mower. **REMEMBER!** This machine is often operated in heavy brush and in heavy weeds. The Blades of this Mower can throw objects if shields are not properly installed and maintained. Serious injury or even death may occur unless care is taken to insure the safety of the operator, bystanders, or passersby in the area. Do not operate this machine with anyone in the immediate area. Stop mowing if anyone is within 100 yards of mower. (SGM-2)



DANGER!



All Safety Shields, Guards and Safety devices including (but not limited to) - the Deflectors, Chain Guards, Steel Guards, Gearbox Shields, PTO integral shields, and Retractable Door Shields should be used and maintained in good working condition. All safety devices should be inspected carefully at least daily for missing or broken components. Missing, broken, or worn items must be replaced at once to reduce the possibility of injury or death from thrown objects, entanglement, or blade contact. (SGM-3)

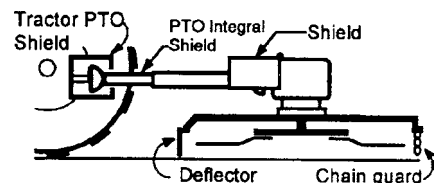

SAFETY

SAFETY

DANGER!



The rotating parts of this machine have been designed and tested for rugged use. However, the blades could fail upon impact with heavy, solid objects such as metal guard rails and concrete structures. Such impact could cause the broken objects to be thrown outward at very high velocities. To reduce the possibility of property damage, serious injury, or even death, never allow the cutting blades to contact such obstacles. (SGM-4)

WARNING!



Extreme care should be taken when operating near loose objects such as gravel, rocks, wire, and other debris. Inspect the area before mowing. Foreign objects should be removed from the site to prevent machine damage and/or bodily injury or even death. Any objects that cannot be removed must be clearly marked and carefully avoided by the operator. Stop mowing immediately if blades strike a foreign object. Repair all damage and make certain rotor or blade carrier is balanced before resuming mowing. (SGM-5)



WARNING!



Many varied objects, such as wire, cable, rope, or chains, can become entangled in the operating parts of the mower head. These items could then swing outside the housing at greater velocities than the blades. Such a situation is extremely hazardous and could result in serious injury or even death. Inspect the cutting area for such objects before mowing. Remove any like object from the site. Never allow the cutting blades to contact such items. (SGM-6)

WARNING!



Mow at the speed that you can safely operate and control the tractor and mower. Safe mowing speed depends on terrain condition and grass type, density, and height of cut. Normal ground speed range is from 0 to 5 mph. Use slow mowing speeds when operating on or near steep slopes, ditches, drop-offs, overhead obstructions, power lines, or when debris and foreign objects are to be avoided. (SGM-7)

WARNING!



Avoid mowing in reverse direction when possible. Check to make sure there are no persons behind the mower and use extreme care when mowing in reverse. Mow only at a slow ground speed where you can safely operate and control the tractor and mower. Never mow an area that you have not inspected and removed debris or foreign material. (SGM-8)

WARNING!



Do not put hands or feet under mower decks. Blade Contact can result serious injury or even death. Stay away until all motion has stopped and the decks are securely blocked up. (SGM-9)

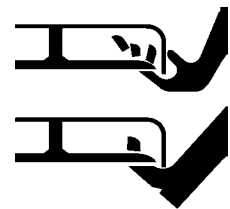

DANGER!



Replace bent or broken blade with new blades. NEVER ATTEMPT TO STRAIGHTEN OR WELD ON BLADES SINCE THIS WILL LIKELY CRACK OR OTHERWISE DAMAGE THE BLADE WITH SUBSEQUENT FAILURE AND POSSIBLE SERIOUS INJURY FROM THROWN BLADES. (SGM-10)

WARNING!



Do not mow with two machines in the same area except with Cab tractors with the windows closed. (SGM-11)

SAFETY

DANGER!



Rotary Mowers are capable under adverse conditions of throwing objects for great distances (100 yards or more) and causing serious injury or death. Follow safety messages carefully.

STOP MOWING IF PASSERSBY ARE WITHIN 100 YARDS UNLESS:

- Front and Rear Deflectors are installed and in good, working condition;
- Mower Head is running close to and parallel to the ground without exposed Blades;
- Passersby are outside the existing thrown-object zone;
- All areas have been thoroughly inspected and all foreign material such as rocks, cans, glass, and general debris has been removed.

NOTE: Where there are grass and weeds high enough to hide debris that could be struck by the blades, the area should be: inspected and large debris removed, mowed at an intermediate height, inspected closely with any remaining debris removed, and mowed again at desired final height. (SBM-1)

WARNING!



Each Rear Wheel must have a minimum of 1,000 pounds contact with the surface to prevent lateral instability and possible tip-over which could result in serious bodily injury or even death. Widen the wheel tread and add weights if needed. Refer to the mounting instructions or call Customer Service if you need assistance with Counterweight Procedure. (SFL-3)

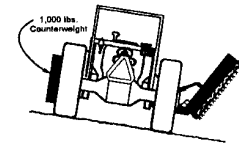

WARNING!



Do not operate Mower if excessive vibration exists. Shut down PTO and the Tractor engine. Inspect the Mower to determine the source of the vibration. If Mower blades are missing or damaged replace them immediately. Do not operate the mower until the blades have been replaced and the Mower operates smoothly. Operating the Mower with excessive vibration can result in component failure and broken objects to be thrown outward at very high velocities. To reduce the possibility of property damage, serious injury, or even death, never allow the Mower to be operated with blades missing. (SFL-4)

WARNING!



Do not let the Blades turn when the Mower Deck is raised for any reason, including clearance or for turning. Raising the Mower deck exposes the Cutting Blades which creates a potentially serious hazard and could cause serious injury or even death from objects thrown from the Blades. (SRM-7)

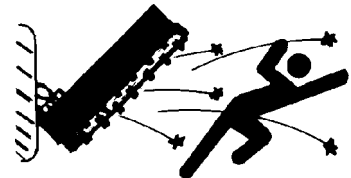

DANGER!



Use extreme caution when raising the Mower head. Stop the Blades from turning when the Mower Head is raised and passersby are within 100 yards. Raising the Mower head exposes the Cutting Blades which creates a potentially serious hazard and can cause serious injury by objects thrown from the Blades or by contact with the Blades.

(SBM-2)

SAFETY

SAFETY

WARNING!



Never leave the Tractor and Implement unattended while the Implement is in the lifted position. Accidental operation of lifting lever or a hydraulic failure may cause sudden drop of unit with injury or death by crushing. To properly park the implement when disconnecting it from the tractor, lower the stand and put the retaining pin securely in place, or put a secure support under the A-Frame. Lower the implement carefully to the ground. Do not put hands or feet under lifted components. (S3PT-1)

WARNING!



Relieve hydraulic pressure prior to doing any maintenance or repair work on the Implement. Place the Mower Head on the ground or securely supported on blocks or stands, disengage the PTO, and turn off the engine. Push and pull the control Levers or Joystick several times to relieve pressure prior to starting any maintenance or repair work. (SBM-6)

DANGER!



Always disconnect the wire leads from the mower valve solenoid before performing service on the Tractor or Mower. Use caution when working on the Tractor or Mower. Tractor engine must be stopped before working on Mower or Tractor. The Mower Blades could inadvertently be turned on without warning and cause immediate dismemberment, injury or death. (SBM-12)

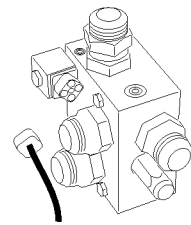

WARNING!



Use extreme care when lowering or unfolding the implement's wings. Make sure no bystanders are close by or underneath the wings. Allow ample clearance around the implement when folding or unfolding the wings. Use extreme caution around buildings or overhead power lines.

(S3PT-

5)

WARNING!



Relieve hydraulic pressure prior to doing any maintenance or repair work on the Implement. Place the Implement on the ground or securely blocked up, disengage the PTO, and turn off the tractor engine. Push and pull the Remote Cylinder lever in and out several times prior to starting any maintenance or repair work. (S3PT-9)



DANGER!



This Implement is wider than the Tractor. Be careful when operating or transporting this equipment to prevent the Implement from running into or striking sign posts, guard rails, concrete abutments or other solid objects. Such an impact could cause the Implement and Tractor to pivot violently resulting in loss of steering control, serious injury, or even death. Never allow the Implement to contact obstacles. (S3PT-12)

DANGER!



The flail cutter shaft is designed for standard rotation (same rotation as the tractor wheel during forward travel). **Never operate the cutter shaft in the reverse rotation.** Operating this mower in reverse rotation may cause objects to be thrown out the front of the mower head.



SAFETY

SAFETY

WARNING!



The rotating parts of this machine continue to rotate even after the Tractor has been turned off. The operator should remain in his seat for 60 seconds after the brake has been set, the PTO disengaged, the tractor turned off, and all evidence of rotation has ceased. (SBM-5)

“Wait a minute...Save a life!”

WARNING!



Engine Exhaust, some of its constituents, and certain components contain or emit chemicals known to the state of California to cause cancer and birth or other reproductive harm.

WARNING!



Battery post, terminals and related accessories contain lead and lead compounds, chemicals known to the state of California to cause cancer and birth or other reproductive harm. **Wash hands after handling!**

Tiger mowers use balanced and matched system components for blade carriers, blades, cutter-shafts, knives, knife hangers, rollers, drive-train components and bearings. These parts are made and tested to Tiger specifications. Non-genuine “will fit” parts do not consistently meet these specifications. The use of “will fit” parts may reduce mower performance, void mower warranties and present a safety hazard. Use genuine Tiger mower parts for economy and safety.

SEE YOUR



DEALER

In addition to the design and configuration of this Implement, including Safety Signs and Safety Equipment, hazard control and accident prevention are dependent upon the awareness, concern, prudence, and proper training of personnel involved in the operation, transport, maintenance, and storage of the machine. Refer also to Safety Messages and operation instruction in each of the appropriate sections of the Tractor and Equipment Manuals. Pay close attention to the Safety Signs affixed to the Tractor and Equipment. (SG-18)

SAFETY

SAFETY

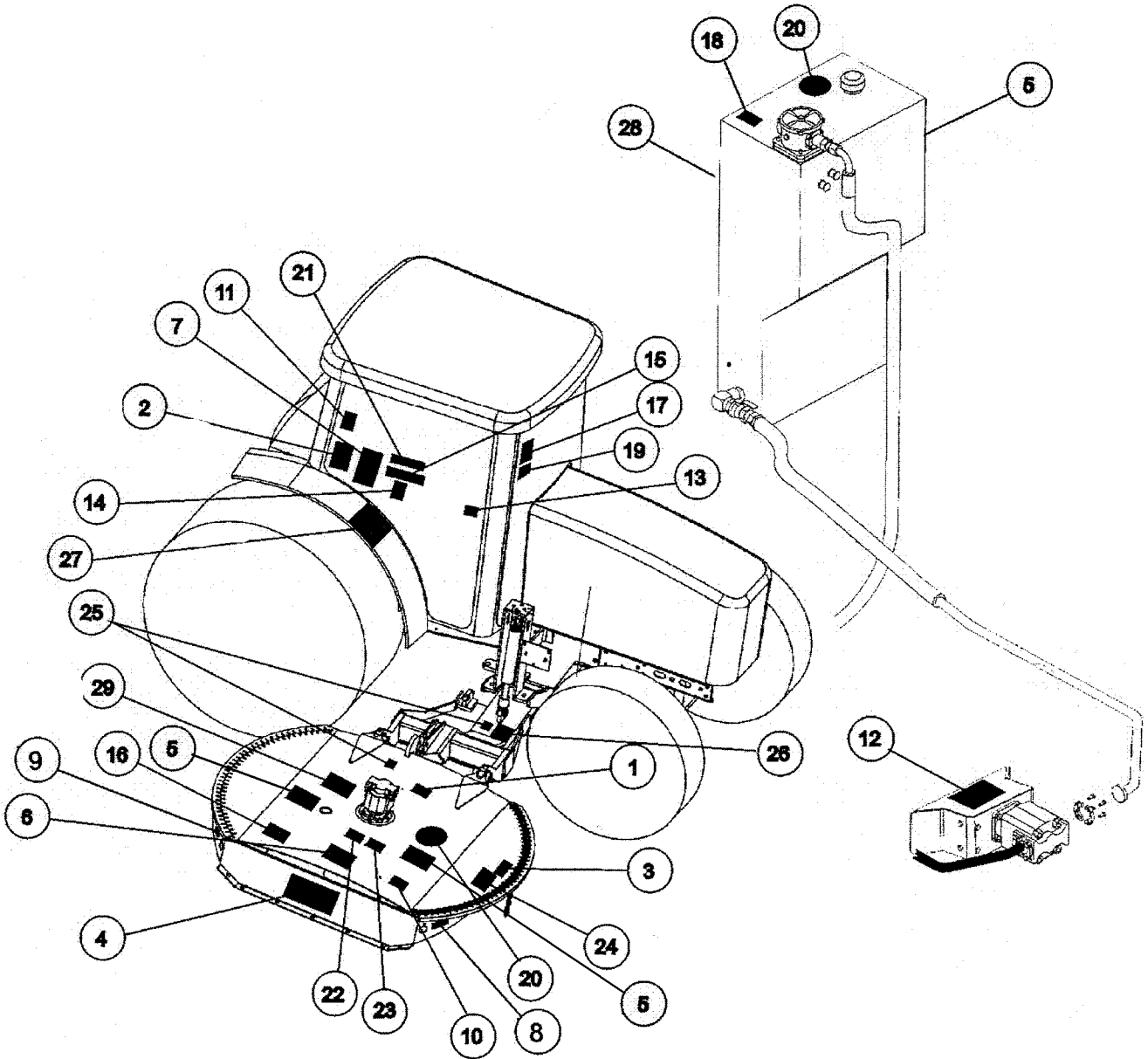

SAFETY

SAFETY

ITEM	PART NO.	QTY.		DESCRIPTION
1	22839	1	INSTRUCT	Don Not Lubricate With Automatic Grease Gun
2	22840	1	WARNING	Foreign Objects Contacted
3	24028	1	WARNING	Inspect Rear Flap
4	31522	1	LOGO	TIGER MOWERS
5	31523	3	LOGO	TIGER MOWERS
6	42350	1	DANGER	Cuttershaft Direction
7	33743	1	INSTRUCT	Mowing Safet Tips
8	42399	1	REFLECT	Red Reflector
9	42400	1	REFLECT	Amber Reflector
10	6T3217	1	DANGER	Keep Hands and Feet Clear
11	6T3219	1	WARNING	Read Operators and Maintenance Manuals
12	6T3220	1	INTRUCT	Lubricate Pump, Driveshaft Daily
13	6T3221	1	CAUTION	Lubricate Spindle When Mower and Tractor Off
14	6T3222	1	INSTRUCT	Engine will not start when mower is engaged
15	1059	1	INSTRUCT	Mower Positions
16	6T3224	1	DANGER	Stay Clear, Discharge Opening
17	6T3230	1	WARNING	Don't Operate with Bystanders in Area
18	6T3233	1	CAUTION	DONOT Start or Run with Valves closed
19	6T3234	1	CAUTION	Check Crankshaft Adapter Daily
20	6T3236	1	LOGO	Made In USA
21	6T3243	1	WARNING	Replace Bolts and Locknut if damaged
22	6T3249A	1	INSTRUCT	Grease Inst. Cuttershaft Bearing
23	6T3261	1	INSTRUCT	Grease Inst. Ground Roller Bearing
24	TB1011	1	WARNING	Do Not Work Mower with Safety Shiel Removed
25	02962764	1	WARNING	Pinch Point
26	02965262	1	WARNING	Hydraulic Hose Repair
27	02967827	1	DANGER	Multi Warn Messages
28	34852	1	INSTRUCT	Hydraulic Specifications
29	00756059	1	WARNING	Check Hydraulic Hose with Cardboard

SAFETY

SAFETY

DO NOT LUBRICATE WITH AUTOMATIC GREASE GUN. GREASE WITH HAND GREASE GUN ONLY.

P/N22839

PART NO.
LOCATION

22839
MOWER DECK



22840
INSIDE OF CAB

WARNING

INSPECT REAR FLAP FREQUENTLY TO BE SURE IT IS IN SAFE WORKING CONDITION. DO NOT OPERATE MOWER WITH FLAP REMOVED OR WORN.

24028

24028
MOWER DECK



10"X5.5" 31522
MOWER DECK

18.25"X10" 31523
HYDRAULIC TANK

SAFETY

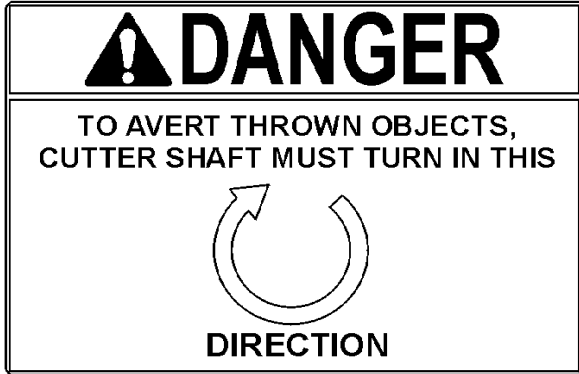

PART NO.
LOCATION

42350
MOWER DECK



33743
INSIDE OF CAB

5

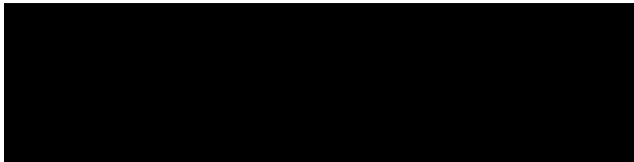

42399
MOWER DECK

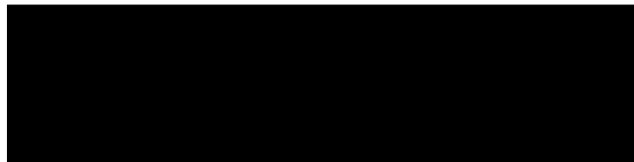

42400
MOWER DECK

SAFETY

SAFETY

SAFETY



PART NO.
LOCATION

6T3217
MOWER DECK



6T3219
INSIDE OF CAB

6T3220
FRONT PUMP MOUNT

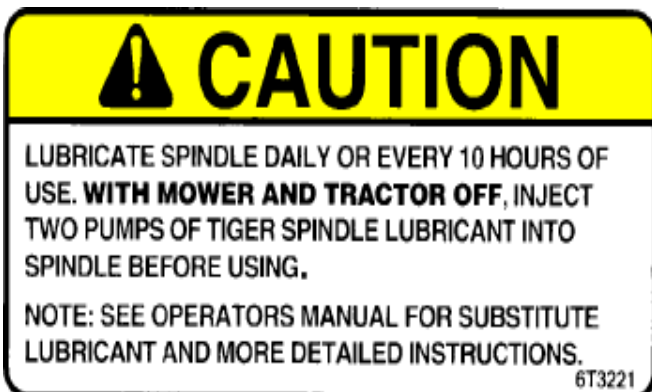

6T3221
INSIDE OF CAB

29-6T3221

SAFETY

NOTICE:
Engine will not
start when mower
is engaged.

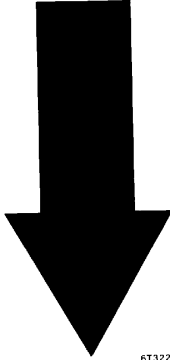

6T3222

PART NO.
LOCATION

6T3233
INSIDE OF CAB

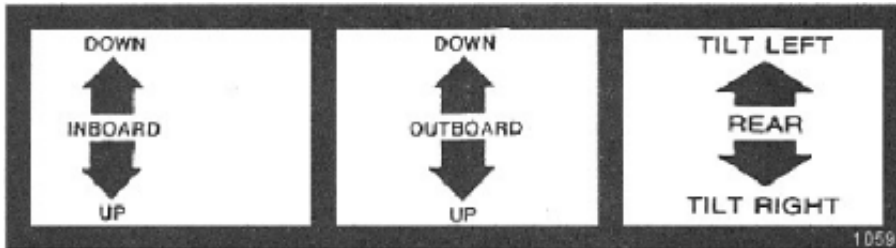

1059

1059

6T3234
INSIDE OF CAB



6T3236
MOWER DECK

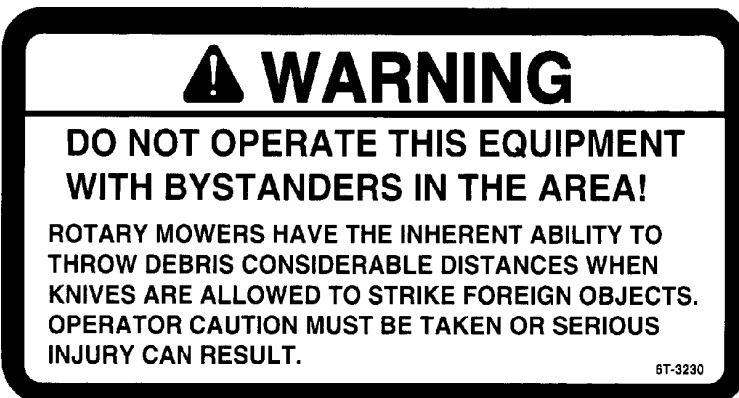

6T-3230

6T3243
INSIDE OF CAB

SAFETY

SAFETY

SAFETY

PART NO.
LOCATION



6T3233
HYDRAULIC TANK



6T3234
INSIDE OF CAB



6T3236
MOWER DECK
HYDRAULIC TANK

6T3243
INSIDE OF CAB

SAFETY

PART NO.
LOCATION

GREASING INSTRUCTIONS

GROUND SHAFT BEARING
GREASE EVERY 8 HRS. OR DAILY

NOTE: If unusual environmental conditions exist; extreme temperatures, moisture, or contaminants more frequent lubrication is required.

6T3249A

6T3249A
MOWER DECK

GREASING INSTRUCTIONS

GROUND ROLLER BEARING
GREASE EVERY 8 HRS. OR DAILY

NOTE: If unusual environmental conditions exist; extreme temperatures, moisture, or contaminants more frequent lubrication is required.

6T3261

6T3261
MOWER DECK

WARNING

**DO NOT OPERATE MOWER
WITH SAFETY SHIELD REMOVED.**

TB1011

TB1011
MOWER DECK



WARNING

PINCH POINTS

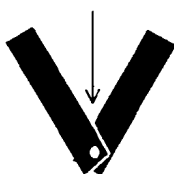

02962764

02962764
MOWER DECK
DRAFT BEAM

SAFETY

SAFETY

SAFETY

PART NO.
LOCATION

02965262
DRAFT BEAM

DANGER

FAILING TO FOLLOW SAFETY MESSAGES AND OPERATING INSTRUCTIONS CAN CAUSE SERIOUS BODILY INJURY OR EVEN DEATH TO OPERATOR AND OTHERS IN THE AREA.

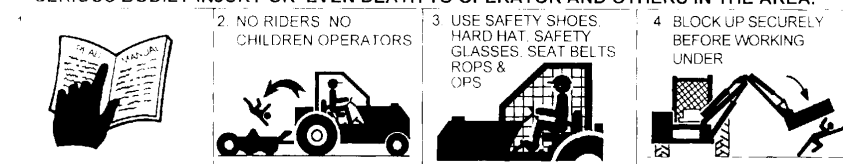

1. Study and understand Operator's Manuals, Safety Decals, and Instructional Decals for tractor and implement to prevent misuse, abuse, and accidents. Practice before operating in a confined area or near passersby.
 - Learn how to stop engine suddenly in an emergency. Be alert for passersby and especially children.
2. Allow no children on or near folding mower or tractor. Allow no riders on tractor or implement. Falling off may cause serious injury or death from being run over by tractor or mower or contact with rotating blades.
3. Operate only with tractor having Roll-Over Protective Structure (ROPS) and with seat belt securely fastened to prevent injury and possible death from falling off or tractor overturn.
 - Personal Protective Equipment such as Hard Hat, Safety Glasses, Safety Shoes, & Ear Plugs are recommended.
4. Block up or support raised machine and all lifted components securely before putting hands or feet under or working underneath any lifted component to prevent crushing injury or death from sudden dropping or inadvertent operation of controls. Make certain area is clear before lowering or folding.
5. Before transporting, put Lift Lever in detent or full-lift position. Install Transport Safety Devices securely on folding mowers. Put Booms securely in Transport Rest.
 - Folding and Boom Mowers have raised center of gravity. Slow down when turning and on hillsides.
6. Make certain that SMV sign, warning lights, and reflectors are clearly visible. Follow local traffic codes.
7. Never operate with Cutting Head or Folding Section raised if passersby, bystanders, or traffic are in the area to reduce possibility of injury or death from objects thrown by Blades under Guards or mower structure.
8. Before dismounting, secure implement in transport position or lower to ground.
 - Put tractor in park or set brake, disengage PTO, stop engine, remove key, and wait until noise of rotation has ceased to prevent crushing by entanglement in rotating parts which could cause injury or death.
 - Never mount or dismount a moving vehicle. Crushing from rollover may cause serious injury or death.

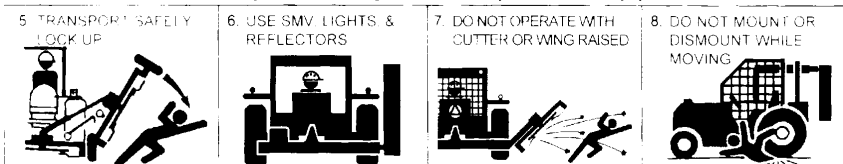

02967827
CAB FENDER

SAFETY



Tiger Corporation

800-843-6849

www.tiger-mowers.com

Description	Application	General Specification	Recommended Lubricant
Tractor Hydraulics	Reservoir	JD-20C	Mobilfluid® 424
Mower Hydraulics	Reservoir	ISO 46 Anti-Wear/ Low Temp	Mobil DTE® 15M
Cold Temperatures 0°F Start-up		JD-20C	Mobilfluid® 424
Normal Temperatures 10°F Start-up		ISO 46 Anti-Wear	Mobil DTE® 25
Normal Temperatures 15°F Start-up		ISO 100 Anti-Wear	Mobil DTE® 15M
High Operating Temperatures Above 90°F Ambient			
Flail Rear Gearbox	Reservoir	PAO Synthetic Extreme Pressure Gear Lube	Mobilube SHC® 75W-90, Mobil 1 Synthetic Gear Lubricant
Cutter Shaft and Ground Roller Shaft (Flail)	Grease Gun	Lithium Complex, NLGI 2 ISO 320	Mobilgrease® CM-S
Drive Shaft Coupler (Rotary and Flail) Drive Shaft Yoke, U - Joint and Stub Shaft	Grease Gun	Lithium Complex, NLGI 2 ISO 320	Mobilgrease® CM-S
Boom Swivel, Boom Cylinder Pivots (Rotary and Flail Boom Type)	Grease Gun	Lithium Complex, NLGI 2 ISO 320	Mobilgrease® CM-S
Deck Boom Pivot & Deck Stop Adjustment (Rotary and Flail)	Grease Gun	Lithium Complex, NLGI 2 ISO 320	Mobilgrease® CM-S
Deck Spindle (Rotary)	Grease Gun	Tiger Spindle Lubricant	Tiger Part #25351

For Mobil product information, availability, or technical information, call 1-800-862-4525.

Tiger PN 34852

34852
HYDRAULIC TANK

WARNING

USE PAPER OR CARDBOARD TO CHECK FOR LEAKS. **NEVER USE YOUR HAND.** IF OIL PENETRATES SKIN, GANGRENE OR OTHER SERIOUS INJURY COULD OCCUR. **GET IMMEDIATE MEDICAL ATTENTION.**
See Operator's Manual.

00756059

00756059
MOWER DECK

SAFETY

SAFETY

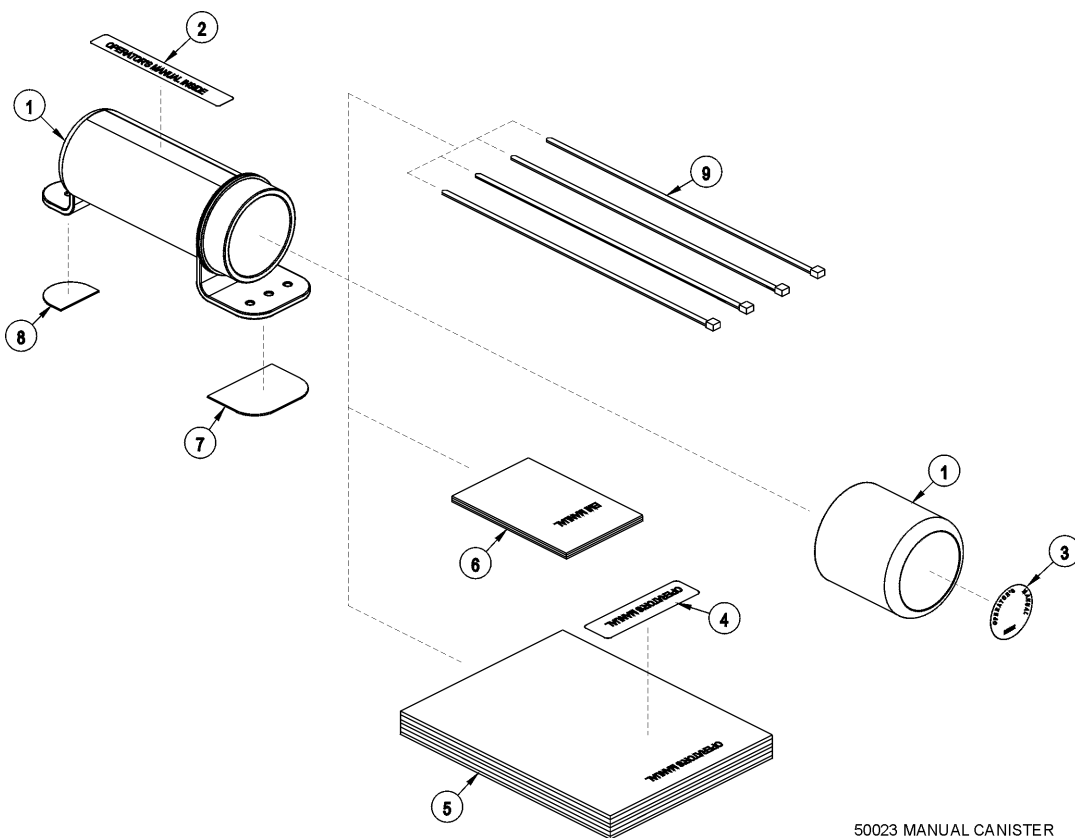

ITEM	PART NO.	QTY.	DESCRIPTION
	50023	AVAIL	MANUAL CANISTER COMPLETE
1	00776031	1	Round Manual Canister
	33997	1	Decal, Sheet, Manual Canister
2		*	Decal
3		*	Decal
4		*	Decal
5	*	AVAIL	Specification Product Manual
6	33753	1	EMI Safety Manual
7	34296	1	Front Adhesive Pad
8	34297	1	Rear Adhesive Pad
9	6T1823	4	Zip Tie 14" Long

NOTE:

The manual canister can be bolted, zip tied or adhered to a variety of surfaces. Locate a protected area within the view of the operator. Then select an installation method and attach the canister. **CAUTION-AVOID DRILLING HOLES INTO UNKNOWN AREAS**, wires and other parts may be located behind these areas. When adhering the canister to a surface, thoroughly clean that surface before installing the canister.

SAFETY

FEDERAL LAWS AND REGULATIONS

This section is intended to explain in broad terms the concept and effect of federal laws and regulations concerning employer and employee equipment operators. This section is not intended as a legal interpretation of the law and should not be considered as such.

Employer-Employee Operator Regulations

U.S. Public Law 91-596 (The Williams-Steiger Occupational and Health Act of 1970) OSHA

This Act Seeks:

“...to assure so far as possible every working man and woman in the nation safe and healthful working conditions and to preserve our human resources...”

DUTIES

Sec. 5 (a) Each employer-

(1) shall furnish to each of his employees employment and a place of employment which are free from recognized hazards that are causing or are likely to cause death or serious physical harm to his employees;

(2) shall comply with occupational safety and health standards promulgated under this Act.

(b) Each employee shall comply with occupational safety and health standards and all rules, regulations and orders issued pursuant to this Act which are applicable to his own actions and conduct.

OSHA Regulations

OSHA regulations state in part: “At the time of initial assignment and at least annually thereafter, the employer shall instruct every employee in the safe operation and servicing of all equipment with which the employee is, or will be involved.”

Employer Responsibilities:

To ensure employee safety during Truck and Implement operation, it is the employer’s responsibility to:

1. Train the employee in the proper and safe operation of the Truck and Implement.
2. Require that the employee read and fully understand the Truck and Implement Operator’s manual.
3. Permit only qualified and properly trained employees to operate the Truck and Implement.
4. Maintain the Truck and Implement in a safe operational condition and maintain all shields and guards on the equipment.
5. Ensure the Truck is equipped with functional seat belts and require that the employee operator securely fasten the safety belts at all times.
6. Forbid the employee operator to carry additional riders on the Truck.
7. Provide the required tools to maintain the Truck and Implement in a good safe working condition and provide the necessary support devices to secure the equipment safely while performing repairs and service.

Child Labor Under 16 Years of Age

Some regulations specify that no one under the age of 16 may operate power machinery. It is your responsibility to know what these regulations are in your own area or situation. (Refer to U.S. Dept. of Labor, Employment Standard Administration, Wage & Home Division, Child Labor Bulletin #102.)

SAFETY

SAFETY

ASSEMBLY SECTION

ASSEMBLY

Before attempting to mount your Tiger mower, it is important to read and understand all of the Safety Messages in the Safety section of this manual.

Check complete shipment list against the packing list to make sure there are no shortages. Make certain the tractor model is the appropriate one for the mower received!

WARNING!



Always use a floor jack, hoist or fork lift to lift and raise heavy parts.

Read and understand the entire assembly section instructions before attempting to mount your Tiger mower. Refer to the parts section of this manual for detailed illustrations to locate all parts.

TRACTOR PREPARATION

- A: Remove right hand steps.
- B: Disconnect battery cables from both batteries.
- C: Remove engine side panels, or raise hood to access front pulley.
- D: Remove plugs from tractor casting where main frame and pump mount will be attached.
- E: Remove any front weights and weight supports.
- F: Raise the tractor onto jack-stands and remove the rear wheels.

ADJUSTING REAR WHEELS

Follow the instructions in the tractor owners manual for adjusting tires and rims. The rear wheels **MUST** be adjusted to the widest setting. **NOTE:** This may require switching the wheels to opposite sides of the tractor. Also take note of any width restrictions when transporting by trailer. (For ease of installation, it is best to leave rear wheels removed during installation of the mower).

CRANKSHAFT ADAPTER

If necessary remove the four capscrews from the crankshaft pulley. Then install the crankshaft adapter plate and adapter to the pulley with capscrews and lockwashers as shown in the parts section.

ASSEMBLY

MAIN FRAME INSTALLATION

With an overhead hoist and / or jack-stands, raise one side of the frame up to the correctly matching mounting holes. Install capscrews and all other hardware as shown in main frame parts section to secure the sides of the main frame to the tractor casting, DO NOT tighten at this time. Remove the capscrews one at a time and apply a thread locking agent. Reinsert the capscrews and tighten / torque to values noted in the torque chart located in the maintenance section of this manual. (The front capscrews are 14mm X 1.5 pitch, Class 10.9. They should be torqued to 155 Ft.-Lbs. - Dry or 122 Ft.-Lbs. - Lubricated.)

AXLE BRACE INSTALLATION

With the tractor on jack-stands, remove the existing hardware and the three point links on the rear axle where the axle braces will be mounted. Use a hoist to raise the axle braces to the correctly matching mounting holes on the rear axle and the main frame. Use the existing hardware to attach the braces to the tractor. **NOTE:** All capscrews are threaded from the bottom up, except the inner rear capscrew. DO NOT tighten the hardware at this time. Remove the capscrews one at a time and apply a thread locking agent. Reinsert the capscrews and tighten / torque to values noted in the torque chart located in the maintenance section of this manual. Reattach the links to the three point hitch with the existing pins.

KUBOTA RIGHT SIDE FUEL TANK

NOTE: THE FUEL TANK IS REPLACED ONLY ON BOOM UNITS.

Drain the right hand fuel tank. Remove the three hoses and the wire connection to the fuel gauge. Remove and reuse the fuel gauge, the gasket and hardware. The gasket has a unique hole pattern and is marked to match the fuel gauge. When taking out the gauge, pull upward until the float reaches the top of the tank. Tip the gauge toward the opposite end of the tank and remove the gauge. Save the gauge for later.

Remove the tank straps and the lower cross bar and discard. Drill two 1/2" holes on the upper front plate according to the measurements shown in the parts section. Drill two 1/2" holes on the lower rear plate according to the measurements in the parts section.

To add the tank gauge to the Tiger tank, first place the gasket that you removed from the original tank on the fuel gauge and match up the holes. Insert the float section of the gauge into the top hole. Then tip the gauge so the long end of the gauge fits into the long end of the tank. Secure the gauge with the existing hardware.

Add the barbed elbow to the top of the tank. Place the rear tank strap over the back end of the tank. Insert the front tank strap into the holes on the top plate and hold in place with the Tiger hardware. Insert the back end of the fuel tank on to the rear plate. Slide the front end of the tank into the front tank straps. Place one piece of split hose on the lower rear plate under the Tiger tank. Thread the Tank strap into the newly drilled holes and add the hardware. Cut the other piece of split hose in half and add them to the front tank strap corners under the tank. This keeps the straps from wearing holes in the tank. Tighten the hardware and secure the fuel tank to the tractor.

Finally, attach the proper hoses to the corresponding holes and add the wires for the fuel gauge. Refer to the parts section for hardware used and dimensions.

ASSEMBLY

FRONT PUMP MOUNTING

Install the pump mounting bracket on the front of the tractor with capscrews and lockwashers as shown in the parts section illustration. DO NOT tighten fasteners at this time.

Slide the pump drive shaft into the crankshaft adapter. The end with the shorter splines should be inserted into the adapter (if applicable).

Slide the splined drive shaft coupler onto the pump drive shaft. Install the pump on the mounting bracket. NOTE: the shaft is offset to one direction, the pump should be installed with the offset side on top. Install hardware for securing pump to the pump mount, DO NOT tighten.

Align pump so that splined coupling can be moved back and forth by hand. Tighten pump mounting bolts in succession rechecking for spline coupling movement. Remove the pump mounting bracket bolts one at a time and apply a thread locking agent. Tighten these bolts in succession, again checking for free movement in the drive shaft. After all bolts are torqued, the end play on the drive shaft should be 1/16" to 1/8", and coupler should move freely with hand pressure. If end play is less than 1/16", grind the end of the shaft to achieve the proper end play. If there is more than 1/4" of end play, return the shaft with specifications for a longer shaft.

CAUTION: DO NOT START THE TRACTOR UNTIL ALL HOSES ARE ATTACHED AND TANK IS FILLED WITH PROPER OIL! STARTING THE TRACTOR AT THIS TIME WILL CAUSE SERIOUS DAMAGE TO THE PUMP.

BUMPER HYDRAULIC TANK INSTALLATION

Install all fittings and tubes into tank and tank filter as shown in the parts section illustration. Insert tank sight glass on the inner right side of the tank. Install the temperature sensor (optional), or pipe plug into side of the tank.

Attach the large mounting brackets on the front casting of the tractor. Secure the brackets to the tank with the hardware shown in the parts section.

Install the filter gauge into the filter housing so that it points to the rear of the tractor and is clearly visible to the operator. The breather cap will be installed after tank is filled.

TEMPERATURE GAUGE MOUNTING

(OPTIONAL)

Mount the temperature gauge where it is clearly visible to the operator. Attach the green (-) wire from the negative post on the gauge to a grounded bolt on the tractor frame. Remove paint if needed to make a good ground. Remove the pipe plug from the side of the hydraulic reservoir, and install the temperature sensor using thread sealing tape. Run the white wire from the (s) sensor post of the gauge to the temperature sensor on the hydraulic reservoir tank.

ASSEMBLY

SIDE ROTARY OR FLAIL HYDRAULIC DIAGRAM

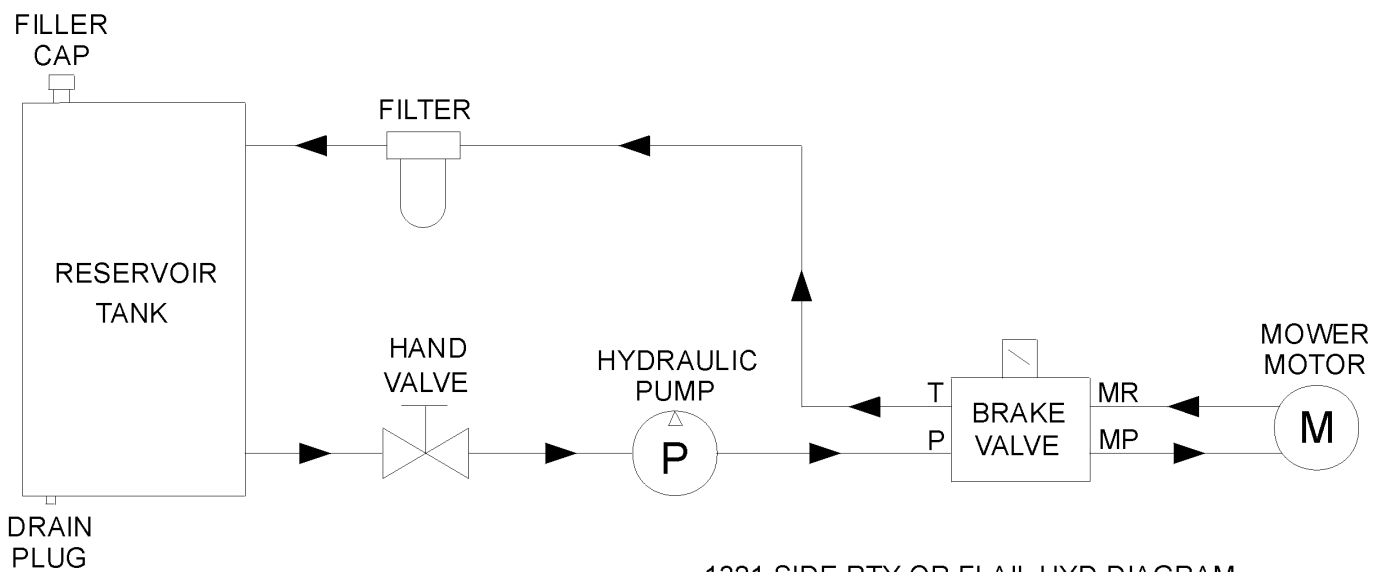
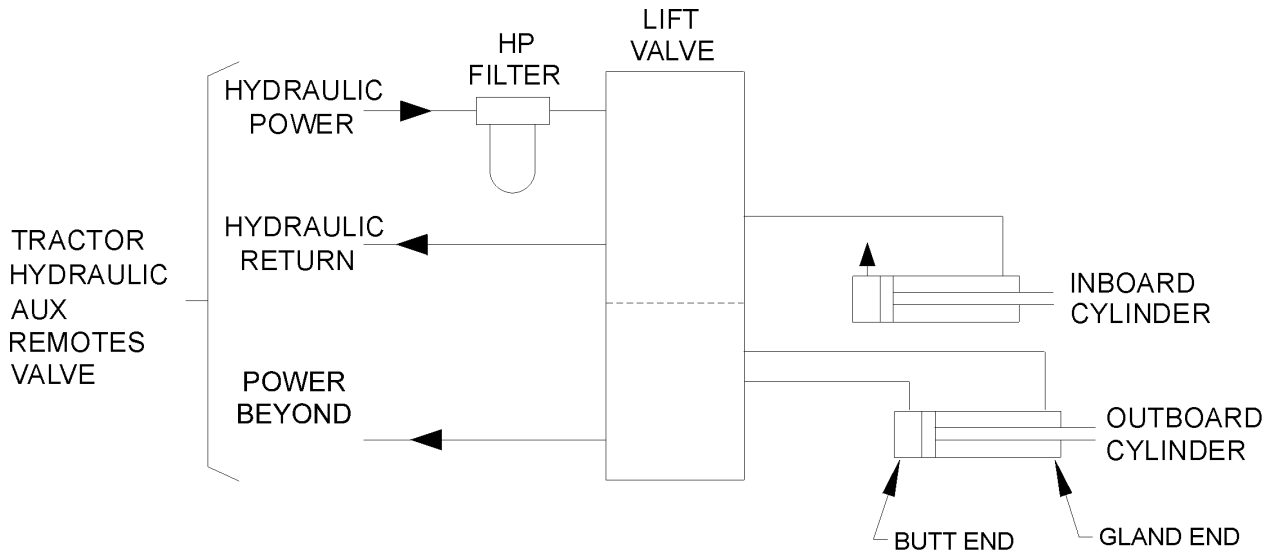

1321 SIDE RTY OR FLAIL HYD DIAGRAM

FILLING HYDRAULIC RESERVOIR

Refer to the maintenance section for filling specifications and hydraulic oil requirements.

NOTE: Starting or running your Tiger mower before filling reservoir will cause serious damage to hydraulic pump.

ASSEMBLY

VALVE MOUNTING BRACKET

The valve mounts are made to fasten to the back fenders of the tractor. The top rear hole on the mounting bracket match an existing hole on the fender. Ream out the existing mounting holes to fit the 3/8" hardware. Attach the valve mounting plate to the brackets. Next, attach the brackets to the fender by the rear holes, level the valve mounting plate and mark the two remaining holes on each bracket. Drill the four remaining 3/8" holes. Apply the hardware to the top two holes of the valve mounting brackets and attach them to the fender.

The ends of the valve mount brace are threaded and the brace supports the lower portion of the bracket. Refer to the parts section for the hardware used. Attach the right lower hole of the bracket to the fender with the 3/8" capscrew, flatwasher and hex nut. Thread the brace on to the end of the lower right capscrew. Attach the other end of the brace to the fender and to the bracket with the other capscrew and flatwasher.

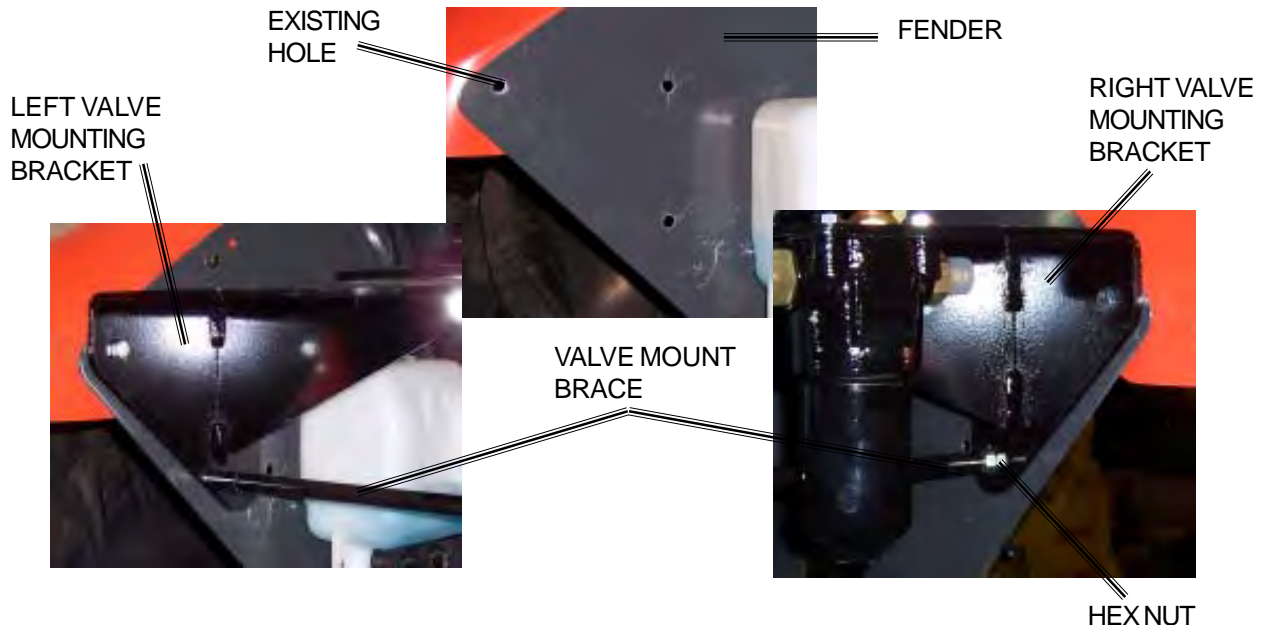

CABLE CONTROL MOUNTING BRACKET

Preassemble the cable control boxes to the control mounting bracket as shown in the parts section. **Use the image below for positioning the cable control bracket.** Position the support bracket on the floor as a template. The upper right hole of the bracket is 2-1/2" from the right edge of the floor mat and 4" from the upper lip of the mat as shown below. The upper left hole of the bracket is 5-5/8" from the upper lip of the mat as shown below. Mark the holes on top of the floor mat. Be sure that the location of the stand will allow clearance between the cable control box handles and all existing interior levers, etc. Also watch out for wiring and brackets when placing the bracket for drilling and cutting. Cut holes in the mat with a 1" hole saw. The spacers provided are used to allow the cable control bracket to set on top of the floor mat while being held securely to the floor of the cab. Drill 3 holes for the capscrews using the bracket and spacers as a template. Then secure with the hardware as noted in the parts section.

ASSEMBLY



2 1/8" HOLE



FRONT STEERING CONSOLE - CUT HOLE TO ACCESS
POWER SOURCE FOR SWITCH BOX

CABLE SWITCH BOX WIRING

Refer to the parts section for wiring diagram to hook up the switch box. Cover the four wires from the switch box with plastic wire wrap provided. Route the wires, that tap into the tractor's power, from the switch box to the front council panel. Remove the console panel under the steering wheel to access wires. Locate the black wire with the white stripe. **Using a test light or meter verify** this wire is the neutral safety wire. Cut the black wire with the white stripe and connect the green wires from the switch box as shown in the wiring diagram. The red wire is to be hooked to the tractor ignition switch or an available slot in the fuse box. **NOTE: Be certain that the power taken for the switch box is "HOT" ONLY when the tractor ignition is "ON". Also double check that the line is fused.**

Cut a 2-1/8" hole through the floor mat and cab floor at the base of the right console and the cable mounting bracket. Check under the cab and under the mat for a clean cut. Run the switch box wires out with the cables and wrap with hose wrap. Secure the hose wrap with zip ties. Place trim lock around the hole. Run the cables to the valve. Run the white wire to the solenoid valve. Cover wires with wire wrap.

The wires from the switch box are longer than needed and should carefully cut and spliced as required. Zip ties should be used to secure the wires and cables to the tractor framework.

ASSEMBLY

HUSCO VALVE MOUNTING

Match the holes on the valve to the holes on the valve plate. The holes on the plate for the cables should be on your right. Always start by matching the mounting holes on the Husco valve to the two mounting holes closest to you on the plate. There will be two more holes on the plate to match the other mounting holes on the valve. Use the hardware shown in the parts section to mount the valve to the valve plate. Refer to the parts section for all parts and hardware needed.

HUSCO HYDRAULIC LINE INSTALLATION

The Tiger Husco valve used needs to access the pressure, return and power beyond ports of the tractor. To access the ports, 1/2" adapters are used.

The pressure port is located under the drivers seat in the cab. Route the hose from the pressure port to the high pressure filter. Next run the pressure hose from the filter to the pressure port on the Husco valve.

The return port is located above the PTO shaft and to the right of the oil filler cap. The return hose runs from the return port on the Husco valve to the return port on the tractor.

The power beyond port is located by the right rear axle of the tractor. Install the hose from the power beyond port of the Husco valve to the power beyond port of the tractor.

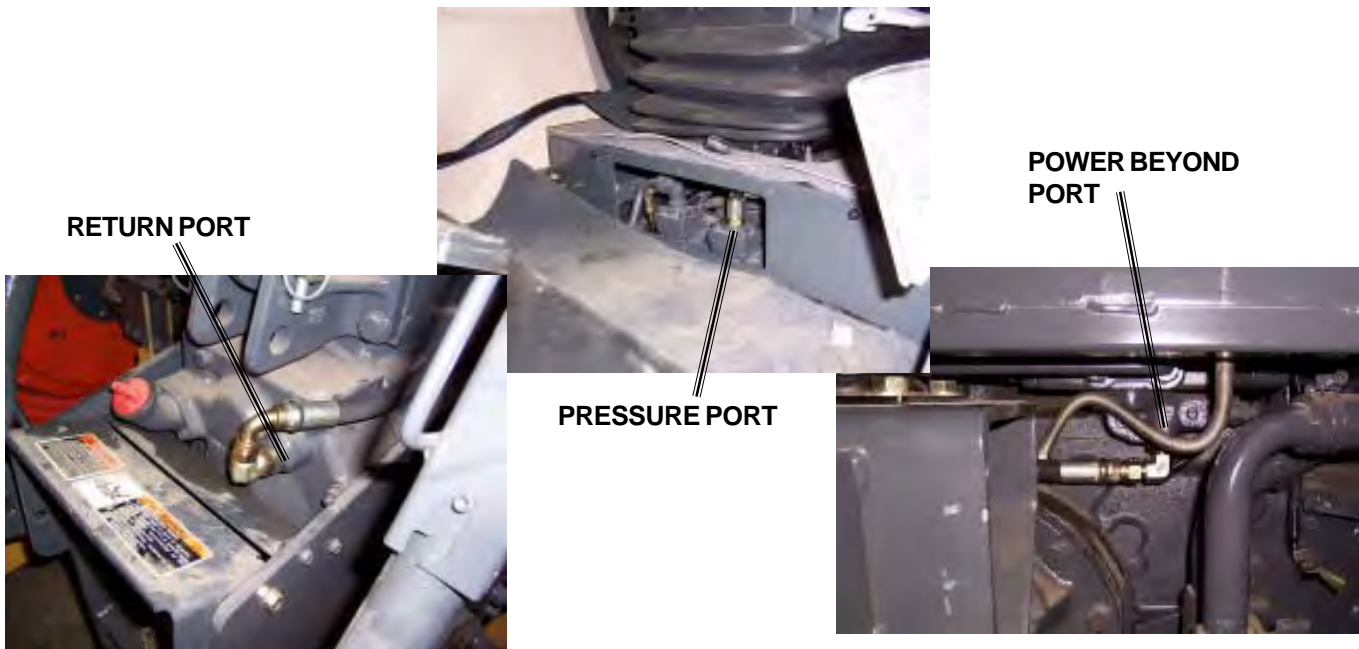

HIGH PRESSURE FILTER - HUSCO

The high pressure filter is mounted to the right valve mounting bracket with two capscrews, as shown in the parts section. Attach the two adapters to the filter. The pressure line from the tractor is plumbed to the left side of the filter. The pressure hose that is attached to the right side of the filter feeds the pressure port of the Tiger lift valve.

ASSEMBLY

POLYCARBONATE SAFETY WINDOWS

NOTE: Installing a boom mower requires that all of the right side windows be replaced with polycarbonate. Install the safety windows after all of the cab wiring and mounting is done; and before the boom arm is mounted. Locate all the hardware in the Parts Section on the Safety Screen page, when installing the polycarbonate.

Remove the right hand rail, the right rear window and the right door from the tractor cab. Remove the hardware and check the parts section for which parts are re-used. Wrap the trim seal around the polycarbonate and cut the trim to match the other end so a seal will form to the frame. Apply the adhesive in the groove of the trim seal where the polycarbonate sits and apply the trim seal to the polycarbonate. Add the hardware for the existing holes to the polycarbonate and install the polycarbonate to the tractor frame.

Locate the 4 holes where the hand rail attaches to the cab. Place the front two support brackets over the holes and attach the hand rail over the brackets with the hardware provided. Place the bottom support bracket in the center of the bottom edge of the door and mark the position of the center hole. Drill one 3/8" hole through the door frame. Use the hardware shown in the parts book to secure the bracket into place.

Locate the existing hardware over the fender in the door frame of the cab. Position the polycarbonate mount over the corresponding holes. Remove the existing hardware. Attach the mount to the fender with the hardware provided. Drill a 5/16" hole through the polycarbonate and secure the window to the mount.



ASSEMBLY

INSTALLING O-RING FITTINGS

Installing straight, 45° and 90° O-rings requires that the O-ring and washer (A) be up against the swivel body (B). Insert the swivel and turn in until the swivel is pointed in the right direction and the O-ring contact is made. Hold swivel in set direction with a wrench and turn the O-ring contact is made. Hold swivel in set direction with a wrench and turn the O-ring nut away from the swivel body and carefully tighten.

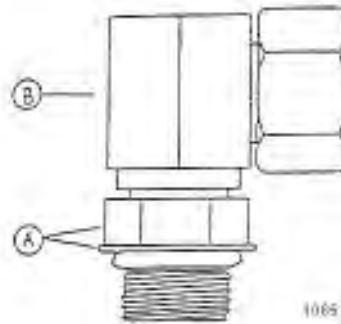

INSTALLING NATIONAL PIPE FITTINGS

Whenever installing a pipe fitting, wrap the thread clockwise (looking at the end) with teflon tape. In this way, the tape will be tightened when installed. NOTE: It is not necessary to tape O-ring fittings, or those installed in swivels.

GENERAL HOSE INSTALLATION

Refer to the parts section for detailed information about hoses and fittings for this application.

Whenever mounting the suction hose between the pump and the tank, the stainless steel bands provided must be used. **CAUTION: DO NOT** use regular hose clamps for this purpose.

HOSE COVERING

Where hoses may contact the frame or other edges, wrap with split hose and secure with hose clamps or zip ties. On non cab units the pressure and return hoses from the control valve will also need to be routed inside the protective clear hose wrap. Cover the valve, valve fittings with the yellow hose cover and secure with black string provided.

ASSEMBLY

WEATHER-PACK/METRI-PACK ASSEMBLY

These instructions apply to both Weather-Pack and Metri-pack connectors.

NOTE: Use the specific tool for the type of connector you are assembling.

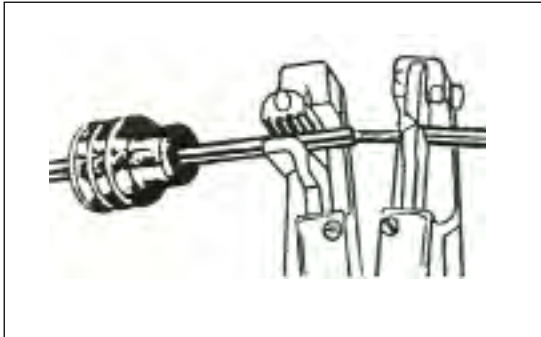

1. Apply seal to cable, before stripping



2. Align seal with cable insulation.

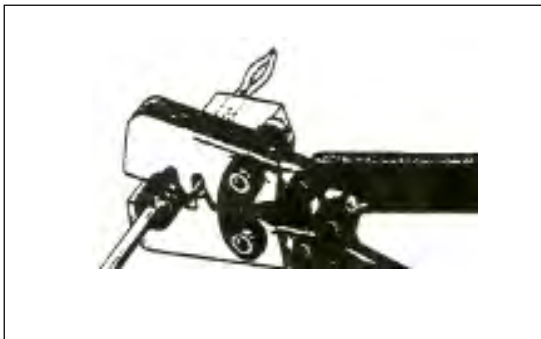

3. Put terminal in crimping tool, then



4. Crimp and visually inspect for a good

ASSEMBLY

COMBO LIFT DRAFT BEAM INSTALLATION

Install ½" O-ring breather into butt port of inboard cylinder. Install fittings in the rod end of the cylinder according to the diagram in the commons section. These fittings should be positioned to face the butt end of the cylinder.

Next turn the clevis onto the rod of the cylinder until it is tight against the shoulder and lock into place with locking bolt on clevis.

The inboard cylinder can now be installed into the main frame mast with the pin, flat-washers and R-clips as shown below. Use teflon tape on all fitting and hose connections.

Install all fittings in the outboard cylinder and adjust to point towards the butt end of the cylinder. Attach the hoses as specified in the parts book. Slide the cylinder into the draft beam from the outside of the draft beam and attach cylinder to the draft beam with clevis pin and rollpins.

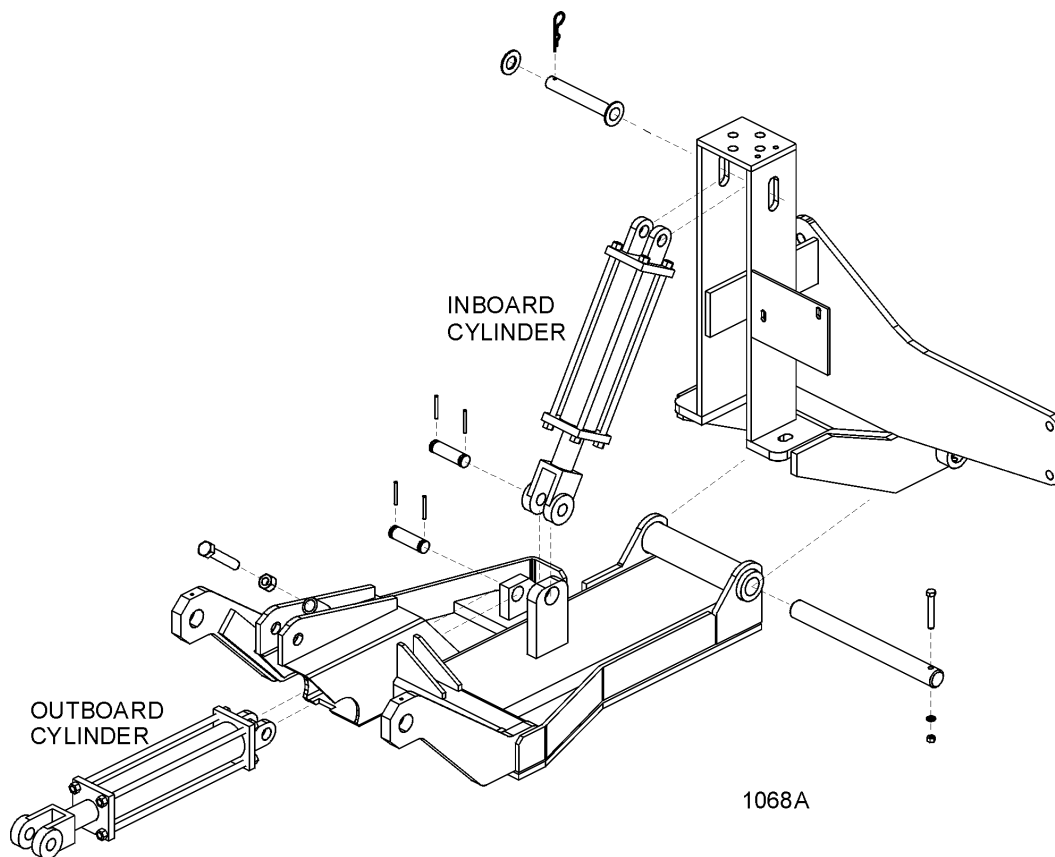

DRAFT BEAM MOUNTING

Pull the inboard cylinder piston rod down to the extreme extended position. Slide the draft beam under the cylinder, and align clevis hole with draft beam hole nearest to the tractor. Install pin and secure with rollpin.

Using inboard cylinder as a pivot point, slide draft beam under tractor and install draft beam pin. Align hole in draft beam pin with holes in main frame boss and install cap-screw, lock-washer and hex nut.

ASSEMBLY

TRAVEL LOCK MOUNTING

Install the travel lock bracket with pin and clip on the draft beam. Slide the draft beam and align the travel lock bracket hole with the mounting hole on the main frame. Install the capscrew, lockwasher and hex nut as shown in the picture.

Raise the deck/flail to it's upright position (Deck ear touches to stop bolt as shown in the picture). Drill a 13/16" hole to the deck/flail ear through the draft beam as shown below. Insert the supplied pin and clip through the hole.

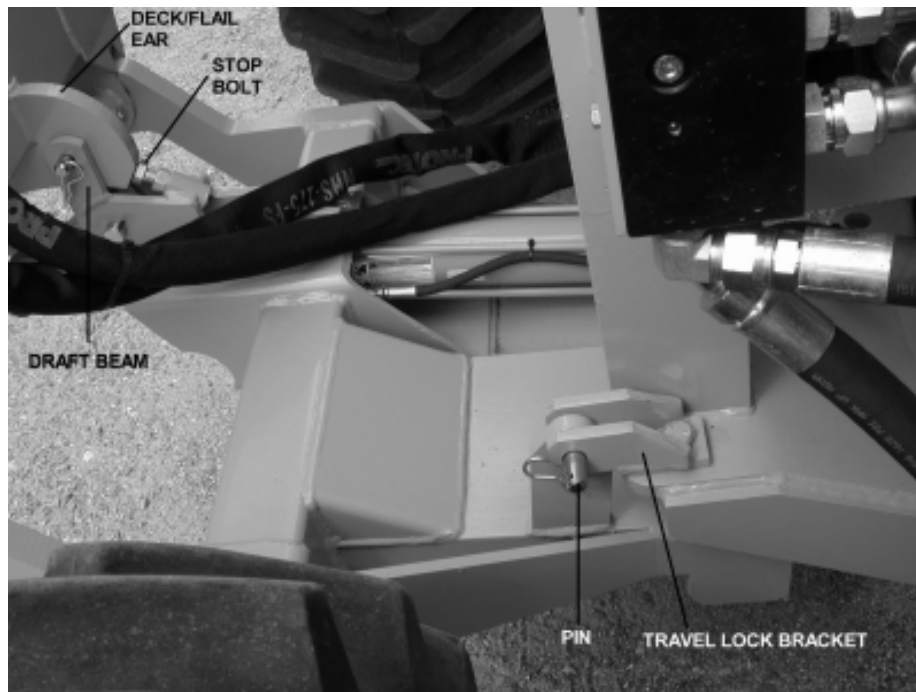

STOP BOLT ADJUSTMENT

The stop bolt is not required on flail side mowers and should not be installed on the combo draft beam.

NOTE: When the outboard cylinder is fully extended, the bonnet should be up against the stop or if travel locks are installed, it should be up against the travel lock. It may be necessary to use either external or internal slugs on the cylinder to get the correct stroke. If the cutter head is against the stop and the cylinder has stroke remaining, serious damage will occur.

Proceed to final preparation for operation instructions on the next page.

ASSEMBLY

DECK MOUNTING

Check that all grease zerks have been installed in the draft beams pivot arm, left linkage arm, right linkage arm, and cylinder mounting ears.

Using a clevis pin and roll pins, connect the pivot arm to clevis on draft beam.

NOTE: Make sure the longer distance between the cutout and the end of the pivot arm is closest to the draft beam pivot ears on the center tube as shown in the diagram below. Also make sure the cutout on the pivot arm faces into tube of draft beam.

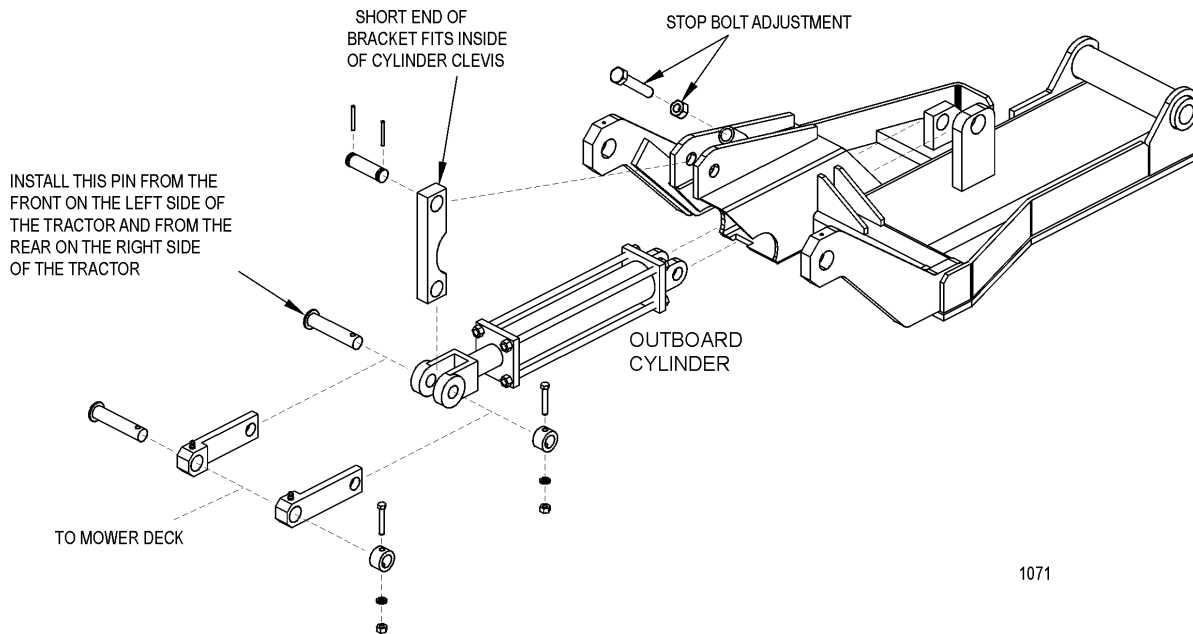

1071

Slide other end of pivot arm with short distance between the cut-out and the end of the pivot arm, into the cylinder clevis. Next, line up the holes of the left and right lift linkage arms outside of the cylinder clevis holes. Connect with linkage pin, shims (as required), boss, cap-screw, lock-washer and hex nut as shown.

To connect the bonnet to the draft beam, slide the extension arms of the draft beam between the mounting ears on the inner end of the bonnet. Line up the holes and secure with swivel pin, cap-screw, lock-washer, and hex nut (both sides). See parts book illustration.

Next, slide the left and right linkage arms up to the slotted ear on the side of the deck. Secure with linkage pin, shims, boss, cap-screw, lock-washer and hex nut. See illustration in parts section.

LIFT CONTROL FEEDLINES

Hose lengths will vary between tractor applications such as cab and non-cab units. See the parts section that pertains to your tractor for hose applications.

Install a hose from the bottom or inner valve port (in fender well for cab units, on stand for non-cab units) to the restrictor on the inboard cylinder gland.

Install a hose from the upper or outer valve port to the restrictor on the outboard cylinder butt. Use teflon tape on all fitting and hose connections.

ASSEMBLY

DECK / MOTOR FEEDLINE

Install the 1" hose with the 90 degree flange on the front side of the motor to the inside upper oil port of the solenoid valve. Secure to motor with flange kit, and install swivel fittings on the other end. Install the other 1" hose with the 60 degree flange on the back side of the motor to the inside lower oil port of the solenoid valve.

Install split hoses around hydraulic hoses where they contact sharp edges, or any other edges that may rub hoses.

Be sure that all grease zerks are installed in the draft beam pin bosses. Grease all areas of the draft beam according to the instructions in the maintenance section. Re-check all fittings for tightness and be sure teflon tape has been used at all connections.

Fill hydraulic tank with fluid as recommended in the maintenance section. **BE SURE TO OPEN THE BALL VALVES.** Start the tractor and operate the inboard cylinder through the entire stroke and the outboard cylinder through the bottom $\frac{3}{4}$ stroke repeatedly to clear the lines of air. **DO NOT run outboard cylinder out to full stroke until stop bolt has been adjusted!**

Check for oil leaks at all fittings and connections using a piece of paper or cardboard. If a leak is found, you must shut down the tractor and set the cutter head on the ground. Before attempting to fix the leak, you must actuate the lift valve handles several times to relieve any pressure in the lines. **DO NOT USE HANDS TO CHECK FOR FLUID LEAKS!**

Raise the three point hitch and check the tractor internal hydraulics, fill to proper level if needed.

ASSEMBLY

FINAL PREPARATION FOR OPERATION

Place operators safety and operation decals on the steering column and side counsel where they are clearly visible to the operator. These decals should be understood by each operator of the machine in conjunction with the safety and operation section of this book. The decals are to remain in good condition as a reminder to the operator, and should be replaced if damaged.

Double check that all pivot points have been greased. Secure all hoses together with zip ties and wrap with split hose sections where friction may occur on the hose.

WARNING!



BEFORE starting or operating the tractor you must read and understand the safety and operation sections of this manual completely.

Before operating the mower, the cutter head and draft beam should be slowly moved throughout the full range of motion. Watch for any condition that would cause pinching or excess stress on the hoses. The steering and front axle travel should also be carefully moved through their full range of motion. If any condition occurs in which the hoses contact the tires, the steering and / or front axle travel may need to be limited as described in the tractor operators manual. This should also be done if the tires rub, or are extremely close to any other part of the mower such as the hydraulic tank or draft beam. This may include adding shims, or adjusting stop bolts in the tractor front to solve the problem. While checking motion, you should also check that the control circuits are connected according to the operators decal for the valve handles.

MOWER TESTING

Take the tractor to a place free of loose objects on the ground. Operate the cylinders through their full range of motion again, to clear the lines of air. Follow the instructions in the operation section to operate the mower. Vibration of the mower should be minimal at all times. After a 5 minute test run, the knife bolts should be retorqued and once again after the first few hours of operation.

If any parts of this assembly section, or any other section of this manual are not clearly understood you must contact your dealer or the address on the front of this manual for assistance!

OPERATION SECTION

OPERATION

Safety is of primary importance to the owner / operator and to the manufacturer. The first section of this manual includes a list of Safety Messages, that, if followed, will help protect the operator and bystanders from injury or death. Many of the messages will be repeated throughout the manual. The owner / operator / dealer should know these Safety Messages before assembly and be aware of the hazards of operating this mower during assembly, use, and maintenance.

The **Safety Alert Symbol** combined with a signal word, as seen below, is intended to warn the owner / operator of impending hazards and the degree of injury possible during operation.

DANGER!



Indicates an imminently hazardous situation that, if not avoided, **WILL** result in DEATH OR VERY SERIOUS INJURY.

WARNING!



Indicates an imminently hazardous situation that, if not avoided, **COULD** result in DEATH OR SERIOUS INJURY.

CAUTION!



Indicates an imminently hazardous situation that, if not avoided, **MAY** result in MINOR INJURY.

IMPORTANT!

Identifies special instructions or procedures that, if not strictly observed, could result in damage to, or destruction of the machine, attachments or the environment.

NOTE: *Identifies points of particular interest for more efficient or convenient operation or repair.* (SG-1)

CAUTION!



Before any operation of tractor and mower, the user should read and understand the safety and operating instructions for both the tractor and the mower. The user should also be familiar with the location and functions of the units instruments and controls. Being familiar with the machine and its controls will increase efficiency and reduce possibility of serious injury or damage to the unit. The operator should work slowly and carefully until he feels comfortable with the machine. Speed and skill will be attained much easier if the necessary time is spent to familiarize yourself with the machine and its operations.

Since tractor makes and models vary, we recommend reading and following the operators manual provided by the manufacturer pertaining to your particular unit.

OPERATION



STARTING TRACTOR AND MOWER



Check the operators manual received from the tractor manufacturer, for their recommendation and procedures pertaining to your particular make and model.

WARNING!



When rotating parts are in motion, serious injury may occur if caution is not used or danger is not recognized. Never allow bystanders within **300 feet** of the machine when mower is in operation.



Be sure the ball valves on the mower hydraulic tank are **OPEN** before starting the tractor. Serious damage to the hydraulic system can occur if the valves are not open.

WARNING!



Check to make sure mower switch is in the “**OFF**” position. The unit is designed not to start if the switch is in the “on” position. If tractor starts with switch on, turn off tractor and contact your local Tiger dealership for assistance.

Start the tractor and allow the instruments to stabilize. Without starting the mower, practice positioning the boom and deck. Remember, speed and skill will be attained easier if the necessary time is spent familiarizing yourself with the machine and its operations. When you feel comfortable at controlling the position of the mower, return the mower to the travel position, and transport the mower to the desired mowing location.

If mowing for the first time with a Tiger Boom Mower, we recommend choosing a ditch or area relatively flat with a minimum of sign posts, guard rails, etc. As always, you should inspect the area for other objects that can cause potential hazards.

The Mower Control switch turns the mower “ON” and “OFF”. This switch is to be in the “OFF” position to start the tractor. The tractor will not start with the switch in the “ON” position.

WARNING!



If tractor starts with switch on, turn off tractor and contact your local Tiger dealership for assistance.

CONTROL LOCATION AND FUNCTIONS

The side mower height is controlled with a two or three spool valve and is coordinated as shown below. The optional three spool valve allows for the operation of a rear rotary mower or side ditcher. If the unit is equipped with a three spool valve, do not operate the third spool handle unless a rear rotary or ditcher is mounted.

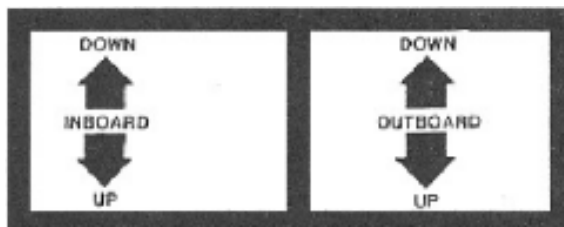

OPERATION

The rear mower height is controlled with the 3-point hitch control lever. Follow the instructions for this control in the tractor operators manual. The tilt of the rear mower is controlled with the third spool of the lift valve and is coordinated as shown above.

The side and rear mower positions may optionally be controlled with the tractor's remote hydraulic connections or a combination of lift valve and remote hydraulics. If so, determine which position of the side or rear mower is to be controlled by each remote lever.

The side mower ON / OFF switch is located in a switch box mounted to the valve stand or cable controls for non-cab and cab units respectively. If operating a rear mower, the ON / OFF switch is located in the switch box with a side mower switch.

This machine may be equipped with an auxiliary oil temperature gauge, an amp gauge or oil pressure gauge. If oil temperature reaches 200 degrees Fahrenheit, stop mowing and see the trouble shooting section for possible causes. Keep an eye on all gauges for indication of problems.

MOWER OPERATION

WARNING!



When rotating parts are in motion, serious injury may occur if caution is not used or danger is not recognized. Never allow bystanders within **300 feet** of the machine when in operation. Extreme care should be taken when operating near loose objects – such as gravel, rocks and debris. These conditions should be avoided.

The rotating parts in this machine have been designed and tested for rugged use. However, they could fail upon impact with heavy solid objects – such as steel guard rails, concrete abutments, etc., causing them to be thrown at a very high velocity. Never allow cutter head to contact such objects. Inspecting the cutting area for such objects prior to mowing can help eliminate these potential hazards.

Once on location, lower the mower deck slightly above the material to be cut, so the mower does not have to start under a load. Bring the R.P.M. of the tractor up to 1200 and engage the side mower. If a rear mower is being used, allow the R.P.M. to return to 1200 before engaging the rear mower.

The rotary mower deck should always be carried rather than dragged on the skid shoes when mowing on the ground. Dragging the rotary mower heads causes an extreme side load on the tractor resulting in premature tire wear. It also causes excessive horsepower consumption and drastically decreases blade life. Dragging the rear mower can also cause damage to the road. Once the necessary skill is attained at controlling the height and position of the side rotary mower, it will be easy to carry the mower head(s) and do a proficient job of cutting.

OPERATION

When cutting tall shrubs or small trees (maximum recommended size of material to be cut is 2" diameter) begin each pass at the top of the material and work down with each consecutive pass. Use a low speed to allow the cutting blades time to mulch as well as cut the foliage. When the initial pass has been made, disengage the mower and return the mower to the travel position. Return to the starting point and make next pass, etc.

CAUTION!



When using the rotary cutting head for trimming trees and shrubs, let the mower saw into them. Do not lower the mower head down directly onto a tree or stump. The mower blades are designed to cut with the end, and misuse can cause damage to the blade and a hazardous situation for the operator.

To ensure a clean cut, engine speed should be maintained at approximately 1800 – 2200 R.P.M. If the tractor slows to less than 1800 R.P.M., shift to the next lower gear. **DO NOT** ride the clutch, this will cause premature clutch failure. **The engine should not be operated at any time at more than 2400 R.P.M. on the tractor tachometer.**

DO NOT use excessive force when positioning cutting head into heavy branches or small stumps (2" diameter). Damage to the unit may result. It is best to let the cutter head "eat away" slowly at heavy cutting jobs.

The mower will operate more efficiently in tougher conditions and with less power if the knives are kept sharp. If the mower begins to vibrate, stop the tractor, check for wire wrapped in the spindle or damaged knives. When replacing knives, replace all knives with new knives to ensure proper balance so the mower will not vibrate. Severe vibration will result, if knives with unequal wear are used. Follow the instructions in the maintenance section closely when replacing knife blades.

WARNING!



If bystanders approach within 300 feet while mower is in operation turn mower switch "OFF" immediately! After shutdown, never leave the tractor or allow bystanders to approach within **300 FEET** of the unit until all motion stops completely.

When encountering a very severe condition which causes the tractor to stall, disengage mower, start tractor, raise the mower from the cut. Shut tractor off and inspect the mower, blades and disk for damage before engaging mower again.

If the blades jam or stop, disengage the clutch and raise the head slightly or back the tractor up. Normally, this will clear the cutter head. If not, shut off the mower(s), raise the cutter heads, turn off the tractor and set the parking brake. After all motion stops completely, leave the tractor and clear the cutting heads manually.

After the first day of operation, all bolts should be checked and tightened securely.

This should be done periodically to ensure the bolts do not become loose and cause damage to the tractor or mower, or injury to the operator.

OPERATION

TRANSPORTING MOWER

Transporting under the units own power:

When transporting between job sites or between cutting passes, the following procedure should be followed: Shut off the power to the cutting head(s) and allow all motion to come to a complete stop. Raise the draft beam to it's highest position. Raise the side mower until the deck stops against the draft beam. Raise the rear mower with the 3-point hitch control lever. The unit is now in position for self transportation.

Transporting unit by flatbed trailer:

Most tractors with a side mounted mower head attached will be over legal transporting width (102" wide). For this reason, one of the following procedures must be followed.

1: Transporting with side mower attached: Use a loading dock or ramp to load tractor onto the trailer. Center the tractor with the mowers attached between the sides of the trailer. Make sure the draft beam and head are fully raised and secured. Lower the rear mower onto the trailer. Secure the tractor and rear mower to the trailer with chains. Obtain proper over-width permits and mark the vehicle and mower as over-width as required be law. Check the tractor operators manual for any tractor requirements to transport by flatbed trailer.

2: Transporting with side mower removed: Park the tractor and turn the engine off. Remove the key to avoid accidental starting. Close ball valves on the hydraulic reservoir. To avoid contaminating the hydraulic system, make sure all fittings on the side mower motor and solenoid control valve are clean. Disconnect the motor pressure hose at the solenoid valve and the motor return hose at the motor. See diagram below.

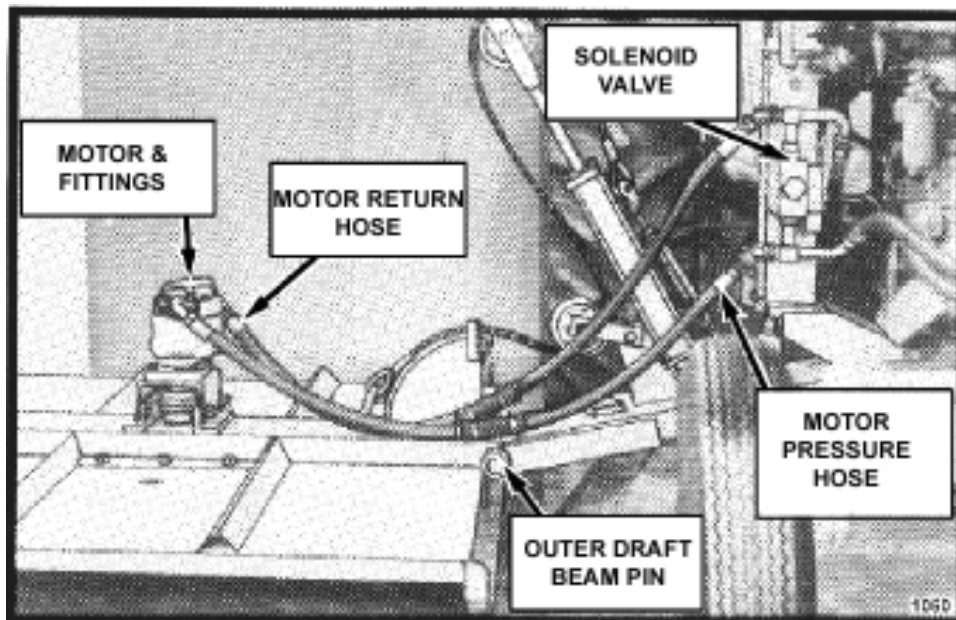

OPERATION

Next, switch the hose ends and reconnect to form two separate closed loops, see diagram below. Disconnect the lift cable from the head and secure the loose end back onto the cable with the cable clevis. Remove the keeper bolt and draft beam outer pivot pin. Separate the mower head from the tractor. Now reinstall the pivot pin and keeper bolts into the draft beam to prevent loss. **OPEN THE BALL VALVES ON THE HYDRAULIC RESERVOIR BEFORE STARTING TRACTOR AGAIN!** Serious damage will be caused if tractor is started with the ball valves closed.

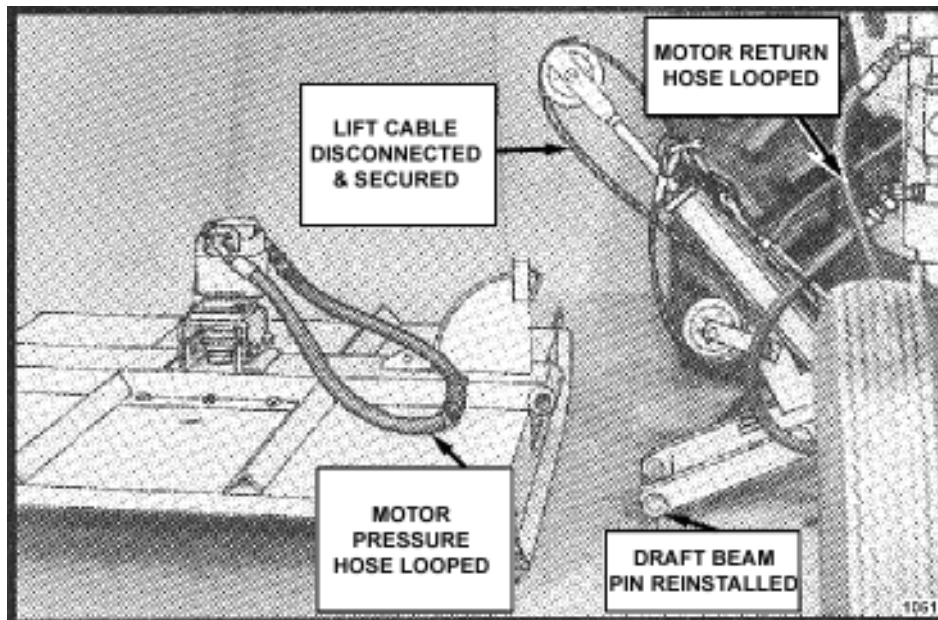

Use a loading dock or ramps to load the tractor onto the trailer, centering the tractor between the sides of the trailer. Make sure the tractor (and rear mower) and trailer are within legal transporting width. Lower the rear mower onto the trailer and set the loose hide mower on the trailer. Secure the tractor and mowers to the trailer with chains. Check the tractor operators manual for any requirements to transport be flatbed trailer. Reverse this procedure to unload and remount the mowers after transporting. Be sure all pins are secure, all connections are tight and any lost fluid is replaced before using mowers. Use teflon tape when connecting all fittings.

CAUTION!



If any part of this operating section, or any other section of this manual is not completely understood, contact your Tiger dealer or the address on the cover of this manual for assistance!

OPERATION

INSPECTION SHEETS

OPERATION

Rotary Mower PRE-OPERATION Inspection



Tractor ID# _____ Make _____

Date: _____ Shift _____

WARNING!



Before conducting the inspection, make sure the Tractor engine is off, all rotation has stop and the tractor is in the Park with the parking brake engaged. The Mower head is resting on the ground (or is securely blocked up and supported) and all hydraulic pressure has been relieved.

Item	Condition at Start of Shift	Specific Comments if not O.K.
The Operator's Manual is in the Canister on the mower		
All Safety Decals are in place and legible		
The Mounting frame bolts are in place and tight		
There are no cracks in Draftbeam or Yolk		
The Draftbeam/Yolk connection bolts & pins are tight		
There are no cracks or holes in mower deck		
The Hydraulic motor mounting bolts are tight		
The mower head spindle housing is tight and lubricated		
There mower deck is clear of cut grass and debris		
The Skid shoes are in good condition & tight		
Chain Guards/Deflectors are in place & in good condition		
Blade carrier retaining nut is tight		
Blades are not chipped, cracked or bent		
Blade bolts are tight		
Transport locks are in good condition		
There are no leaking or damaged hoses		
There is no evidence of Hydraulic leaks		
The Hydraulic Oil level is full		
The Hydraulic Cylinders pins are tight		
The Hydraulic Pump hose connections are tight		
The Hydraulic Valve hose connections are tight		
The Hydraulic Valve controls function properly		
Wheel lug nuts are tight		

Operators Signature: _____

DO NOT OPERATE an UNSAFE TRACTOR or MOWER

OPERATION

TRACTOR PRE-OPERATION Inspection



Tractor ID# _____ Make _____

Date: _____ Shift _____

WARNING!



Before conducting the inspection, make sure the Tractor engine is off, all rotation has stop and the tractor is in the Park with the parking brake engaged. The Mower head is resting on the ground (or is securely blocked up and supported) and all hydraulic pressure has been relieved.

Item	Condition at Start of Shift	Specific Comments if not O.K.
The Flashing lights function properly		
The SMV Sign is clean and visible		
The Tires are in good condition with proper pressure		
The Wheel Lug bolts are tight		
The tractor Brakes are in good condition		
The Steering linkage is in good condition		
There are no visible Oil Leaks		
The Hydraulic controls function properly		
The ROPS or ROPS Cab is in good condition		
The Seatbelt is in place and in good condition		
The 3-Point Hitch is in good condition		
The Drawbar pins are securely in place		
The PTO Master Shield is in place		
The Engine Oil level is full		
The Brake Fluid level is full		
The Power Steering Fluid Level is full		
The Fuel level is adequate		
The Engine Coolant Fluid level is full		
The Radiator is free of debris		
The Air filter is in good condition		

Operators Signature: _____

DO NOT OPERATE an UNSAFE TRACTOR or MOWER

OPERATION

FRONT END LOADER PRE-OPERATION Inspection



Mower ID# _____ Make _____

Date: _____ Shift _____

WARNING!



Before conducting the inspection, make sure the Tractor engine is off, all rotation has stop and the tractor is in the Park with the parking brake engaged. The Loader is resting on the ground (or is securely blocked up and supported) and all hydraulic pressure has been relieved.

Item	Condition at Start of Shift	Specific Comments if not O.K.
The Operator's Manual is in the Canister on the mower		
All Safety Decals are in place and legible		
The Mounting frame bolts are in place and tight		
There are no cracks in Draftbeam or Yolk		
The Draftbeam/Yolk connection bolts & pins are tight		
There are no cracks or holes in mower deck		
The Hydraulic motor mounting bolts are tight		
The mower head spindle housing is tight and lubricated		
There mower deck is clear of cut grass and debris		
The Skid shoes are in good condition & tight		
Chain Guards/Deflectors are in place & in good condition		
Blade carrier retaining nut is tight		
Blades are not chipped, cracked or bent		
Blade bolts are tight		
Transport locks are in good condition		
There are no leaking or damaged hoses		
There is no evidence of Hydraulic leaks		
The Hydraulic Oil level is full		
The Hydraulic Cylinders pins are tight		
The Hydraulic Pump hose connections are tight		
The Hydraulic Valve hose connections are tight		
The Hydraulic Valve controls function properly		
Wheel lug nuts are tight		

Operators Signature: _____

DO NOT OPERATE an UNSAFE TRACTOR or FRONT END LOADER

OPERATION

TRACTOR PRE-OPERATION Inspection



Tractor ID# _____ Make _____

Date: _____ Shift _____

WARNING!



Before conducting the inspection, make sure the Tractor engine is off, all rotation has stop and the tractor is in the Park with the parking brake engaged. The Loader is resting on the ground (or is securely blocked up and supported) and all hydraulic pressure has been relieved.

Item	Condition at Start of Shift	Specific Comments if not O.K.
The Flashing lights function properly		
The SMV Sign is clean and visible		
The Tires are in good condition with proper pressure		
The Wheel Lug bolts are tight		
The Tractor Brakes are in good condition		
The Steering linkage is in good condition		
There are no visible Oil Leaks		
The Hydraulic controls function properly		
The ROPS or ROPS Cab is in good condition		
The Seatbelt is in place and in good condition		
The PTO Master Shield is in place		
The Engine Oil level is full		
The Brake Fluid level is full		
The Power Steering Fluid Level is full		
The Fuel level is adequate		
The Engine Coolant Fluid level is full		
The Radiator is free of debris		
The Air filter is in good condition		

Operators Signature: _____

**DO NOT OPERATE an UNSAFE TRACTOR or FRONT END
LOADER**

MAINTENANCE SECTION

MAINTENANCE

Tiger Mowers are designed for high performance and rugged durability, yet with simplified maintenance. The purpose of this section of the manual is to help the operator in the regular servicing of the mower. Regular maintenance at the intervals mentioned will result in the maximum efficiency and long life of the Tiger Mower.

When you purchase a Tiger Mower you also acquire another valuable asset, Tiger's parts organization. Our rapid and efficient service has guaranteed the customer satisfaction for many years. Tiger parts keep up with the demands for efficiency, safety and endurance expected of the Tiger Mower.

MAINTENANCE PRECAUTIONS

Be sure end of grease gun and zerks are clean before using. Debris injected into bearings, etc. with grease will cause immediate damage.

DO NOT use a power grease gun to lubricate bearings. These require very small and exact amounts of lubrication. Refer to the detailed maintenance section for specific lubrication instructions. Do Not over-grease bearings.

Lexan windows should be washed with mild soap or detergent and luke warm water, using a soft clean sponge or **soft cloth**. DO NOT use abrasive or alkaline cleaners or metal scrapers on lexan windows!

Be alert to maintenance indicators such as the in-tank filter pressure gauge, hydraulic reservoir sight gauge, etc. Take the required action to correct any problems immediately.

Release of energy from pressurized systems may cause inadvertent actuation of cylinders, or sudden release of compressed springs. Before disconnecting any hoses relieve pressure by shutting tractor off, setting cutter on ground and actuating lift valve handles.

WARNING!



DO NOT use hands to check for suspected leaks in hydraulic hoses! Hydraulic fluid escaping under pressure can have sufficient force to penetrate skin and cause serious injury. If fluid is injected into skin, it must be surgically removed within a few hours or gangrene may result. Use a small piece of wood or cardboard, not hands, to search for pin hose leaks. Be sure all pressure is relieved whenever disconnecting lines. Be sure all connections are tight and hoses and lines are not damaged before applying pressure.

BREAK IN PERIOD

In addition to following the break in instructions for your particular tractor, the in-tank hydraulic fluid filter should be replaced after the first 50 hours of service. Thereafter the filter should be replaced every 500 hours, or yearly, whichever comes first.

Re-torque wheel lugs after first five hours of operation and periodically thereafter. See torque specifications listed in the tractor's service manual for your particular model. **Wheel lugs must always be re-torqued whenever a wheel is removed and reinstalled.**

MAINTENANCE

REGULAR MAINTENANCE

The intervals at which regular servicing should be done are based on hours of operation. Use the tractors hour meter to determine when regular servicing is required.

This symbol indicates a point that needs to be greased at an interval noted in the section below. Refer to the Detailed Maintenance section for further instructions on greasing. Copy and use the Daily Maintenance sheet located at the end of this section.



DAILY OR EVERY 8 HOURS

ITEM	SERVICE	COMMENTS
Drive Shaft Yoke, U-Joint & Stub Shaft	Grease	Grease as instructed in detailed maint. section
Pump Drive Shaft	Check and Lube	Insure drive shaft end play
Crankshaft Adapter	Check rubber grommets	Replace grommets if damaged or missing
Pivot Points	Lubricate	Inject grease until it appears at ends
Hydraulic Fittings	Check for leaks	Tighten when needed. Do Not use hands to check for leaks, see maintenance precautions
Knives	Check	Inspect for missing or damaged knives, change or sharpen as needed
Spindle mounting bolts (spindle to deck)	Check	3/4" x 2" torque to 331 ft. lbs.
Knife mounting bolts (knife to disk)	Check	Pre-lubricate threads, then torque to 800 ft.lbs
Disk mounting bolts (disk to spindle)	Check	5/8" x 1-3/4" bolt to torque 204 dry or 184 oiled ft. lbs.
Belts	Check / Adjust	Check if broken, tighten as required
Main Frame and Deck	Check	Retorque bolts to torque specifications in this section
Hydraulic Fluid Level	Check	Add if required per fluid recommendations

MAINTENANCE

WEEKLY OR EVERY 50 HOURS

ITEM	SERVICE	COMMENTS
In Tank Hyd. Fluid Filter (10 micron filter)	Change	Change after first 50 hours only, then every 500 hours or yearly
In-Line High Pressure Filter (10 micron filter)	Change	Change after first 50 hours only, then every 500 hours or yearly

MONTHLY OR EVERY 150 HOURS

Hydraulic Fluid Level	Check	Add as needed
Hyd. Tank Breather	Clean / Check / Replace	Clean or replace Element as required
Rear Tire Type	Max P.S.I.	
480/80R38	29	
18.4-34	26	
18.4-38	26	

YEARLY OR EVERY 500 HOURS

Spindle Grease	Change	
Motor to Spindle Spline	Change	
Hyd. Tank Fluid	Change	
In Tank Hyd. Fluid Filter (10 micron filter)	Change	
In-Line HP Filter (10 micron filter)	Change	or Change when indicated by restriction indicator.
Hyd. Tank Breather	Change	

TROUBLE SHOOTING

SYMPTOMS	CAUSE	REMEDY
Vibration	<ol style="list-style-type: none"> Loose bolts Cutter assembly 	<ol style="list-style-type: none"> Check all bolts and tighten to torque specs. in this section <ol style="list-style-type: none"> Check for damaged blades, disc. Unbalanced or cutter shaft. Replace if needed. Check for wire, rope, etc. entangled in cutter assembly
Mower will not lift	<ol style="list-style-type: none"> Hyd. Fluid low Leaks in line Faulty relief valve Kinked or blocked Faulty cylinder 	<ol style="list-style-type: none"> Check and refill Hyd. Fluid. Tighten or replace fittings and hoses Check pressure in line. Line pressure in Control Valves should be at least 2500 P.S.I. Clean or replace lines Inspect, repair or replace cylinder

MAINTENANCE

SYMPTOMS	CAUSE	REMEDY
Oil Temperature rises above 200 deg. F	<ol style="list-style-type: none"> 1. Low oil level 2. Kinked/blocked hoses 3. Worn pump / motor 	<ol style="list-style-type: none"> 1. Bring oil to proper level 2. Inspect / Repair / Replace 3. Disable and repair
Mower will not start or run	<ol style="list-style-type: none"> 1. Blown fuse 2. Ball valves closed 3. Low oil level 4. Line leak 5. Electronic solenoid faulty 	<ol style="list-style-type: none"> 1. Check fuse between mower switch and ignition / replace 2. Make sure valves are open 3. Check Hyd. tank and fill 4. Check all fittings and lines. Re-tighten or replace 5a. Without the tractor running, turn the mower switch to on. A low audible click should be heard if the solenoid is engaging the solenoid spool. If click is not heard, leave switch in on position and with a screwdriver or other steel object, touch the small nut on the end of the solenoid. If the metallic object is not attracted to the nut, check the fuse and wiring for an open circuit. If the object is attracted but no "click" is heard, replace the solenoid. 5b. Remove the four bolts holding the small block to the main block. Lift and remove small block being careful not to damage O-rings / filter. Clean filter and re-install. 5c. Remove large nut on side of large valve block. Remove spring, and use needle nose vise grip to pull spool from block. Check block and spool for contaminates and scratches. Clean parts or replace if scratched.
Motor runs but will not cut.	<ol style="list-style-type: none"> 1. Belts 2. Tensioner 	<ol style="list-style-type: none"> 1. Inspect belts and pulleys. Replace belts and repair as needed. 2. Adjust tensioner nut until flat washer washer is flush with top of guide.
Motor turns slowly or not at all.	<ol style="list-style-type: none"> 1. Contaminants restricting spool movement in valve body. 2. Suction lines obstructed 3. Low oil level 	<ol style="list-style-type: none"> 1. Remove large nut on side of large valve block. Remove spring, and use needle nose vise grip to pull spool from block. Check block and spool for contaminates and scratches. Clean parts or replace if scratched. 2. Check for kinkes or obstruction in suction hose 3. Check Hyd. tank level and fill
Pump will not work	<ol style="list-style-type: none"> 1. Excessive wear on internal parts 	<ol style="list-style-type: none"> 1. Disassemble and repair.

MAINTENANCE

Motor will not work 1. Excessive wear on internal parts 1. Disassemble and repair.

NOTE: If flow meter is available, check pressure and flow volume for all suspected hydraulic problems.

If the solution to your problem cannot be found in this section, call the Technical Service representative at the number shown on the front cover of this manual.

MAINTENANCE

TORQUE SPECIFICATIONS

Torque for Standard Fasteners													
Nominal Dia. (in.)	threads per inch	Grade 2			Grade 5			Grade 8			Grade 9		
		Tightening Torque			Tightening Torque			Tightening Torque			Tightening Torque		
		Lubed	Dry Plated	Dry plain	Lubed	Dry Plated	Dry plain	Lubed	Dry Plated	Dry plain	Lubed	Dry Plated	Dry plain
		K = 0.15	K = 0.17	K = 0.20	K = 0.15	K = 0.17	K = 0.20	K = 0.15	K = 0.17	K = 0.20	K = 0.15	K = 0.17	K = 0.20
Unified Coarse Thread Series													
1/4	20	49 in-lbs	59 in-lbs	65 in-lbs	76 in-lbs	86 in-lbs	101 in-lbs	107 in-lbs	122 in-lbs	143 in-lbs	126 in-lbs	143 in-lbs	168 in-lbs
5/16	18	101	122	135	157	178	209	221	251	296	269	294	346
3/8	16	15 ft-lbs	18 ft-lbs	20 ft-lbs	23 ft-lbs	26 ft-lbs	31 ft-lbs	33 ft-lbs	37 ft-lbs	44 ft-lbs	38 ft-lbs	43 ft-lbs	51 ft-lbs
7/16	14	24	29	32	37	42	49	52	59	70	61	70	82
1/2	13	37	44	49	57	64	75	80	90	106	94	106	125
9/16	12	53	63	70	82	92	109	115	130	154	135	153	180
5/8	11	73	87	97	113	128	150	159	180	212	186	211	248
3/4	10	129	155	172	200	227	267	282	320	376	331	375	441
7/8	9	125	150	167	322	365	429	455	515	606	533	604	710
1	8	187	225	250	483	547	644	681	772	909	799	905	1065
1 1/8	7	266	319	354	596	675	794	966	1095	1268	1132	1263	1510
1 1/4	7	375	450	500	840	952	1121	1363	1545	1817	1597	1810	2130
1 1/2	6	652	783	869	1462	1657	1950	2371	2688	3162	2779	3150	3706
Fine Thread Series													
1/4	28	56 in-lbs	68 in-lbs	75 in-lbs	87 in-lbs	99 in-lbs	116 in-lbs	123 in-lbs	139 in-lbs	164 in-lbs	144 in-lbs	163 in-lbs	192 in-lbs
5/16	24	112	135	150	174	197	231	245	278	327	287	325	383
3/8	24	17 ft-lbs	20 ft-lbs	23 ft-lbs	26 ft-lbs	30 ft-lbs	35 ft-lbs	37 ft-lbs	42 ft-lbs	49 ft-lbs	43 ft-lbs	49 ft-lbs	58 ft-lbs
7/16	20	27	32	36	41	47	55	58	66	78	68	78	91
1/2	20	41	49	55	64	72	85	90	102	120	105	120	141
9/16	18	59	71	78	91	103	121	128	146	171	151	171	201
5/8	18	82	99	110	127	144	170	180	204	240	211	239	281
3/4	16	144	173	192	223	253	297	315	357	420	369	418	492
7/8	14	138	165	184	355	403	474	502	568	669	588	666	784
1	14	210	252	280	542	614	722	765	867	1020	896	1016	1195
1 1/8	12	296	357	397	668	757	890	1083	1227	1444	1269	1439	1693
1 1/4	12	415	498	553	930	1055	1241	1509	1710	2012	1768	2004	2368
1 1/2	12	734	880	978	1645	1865	2194	2668	3024	3557	3127	3544	4169

Torque values for 1/8 and 5/16 in series are in inch-pounds. All other torque values are in foot-pounds. K = 0.15 for "lubricated" conditions D = Nominal Diameter
 Torque values calculated from formula T=KDF, where K = 0.17 for zinc plated and dry conditions F = Clamp Load
 K = 0.20 for plain and dry conditions

Torque-Tension Relationship for Metric Fasteners												
Nominal Dia. (mm)	Pitch	Class 4.6			Class 8.8			Class 10.9			Class 12.9	
		Tightening Torque			Tightening Torque			Tightening Torque			Tightening Torque	
		Lubed	Dry Plated	Dry plain	Lubed	Dry Plated	Dry plain	Lubed	Dry Plated	Dry plain	Lubed	Dry plain
		K = 0.15	K = 0.17	K = 0.20	K = 0.15	K = 0.17	K = 0.20	K = 0.15	K = 0.17	K = 0.20	K = 0.15	K = 0.20
3	0.5	0.26	0.32	0.38	0.73	0.82	0.87	1.0	1.2	1.4	1.2	1.6
3.5	0.8	0.44	0.50	0.59	1.1	1.3	1.5	1.6	1.9	2.2	1.9	2.5
4	0.7	0.66	0.74	0.87	1.7	1.9	2.3	2.4	2.7	3.2	2.8	3.8
5	0.8	1.3	1.5	1.8	3.4	3.9	4.5	4.9	5.5	6.5	5.7	7.6
6	1	2.3	2.6	3.0	5.8	6.6	7.7	8.3	9.4	11	9.7	13
6	1.25	2.1	2.3	2.7	5.3	6.0	7.0	7.6	8.6	10	8.8	12
7	1	3.8	4.3	5.0	9.7	11	13	14	16	19	16	22
8	1	5.9	6.6	7.8	15	17	20	22	24	29	25	34
8	1.25	5.5	6.2	7.3	14	16	19	20	23	27	24	31
10	1.25	11	13	15	29	33	39	42	48	56	49	66
10	1.5	11	12	14	28	32	37	40	45	53	47	62
12	1.25	21	23	28	53	60	71	76	86	101	89	119
12	1.5	20	22	26	51	58	68	73	82	97	85	113
12	1.75	19	21	25	49	55	65	70	79	93	81	108
14	1.25	26	29	34	66	75	89	95	108	127	111	148
14	1.5	26	32	37	72	82	96	103	117	136	121	161
14	2	30	34	40	78	88	104	111	126	148	130	173
16	1.5	50	57	67	129	146	171	184	208	245	215	287
16	2	47	53	62	121	137	161	173	196	230	202	269
18	1.5	73	82	97	187	212	249	268	303	357	313	417
18	2.5	65	73	86	167	189	222	239	270	318	279	372
20	2.5	91	104	122	236	267	314	337	382	449	394	525

Clamp load calculated as 75% of the proof load for specified bolts. K = 0.15 for "lubricated" conditions D = Nominal Diameter
 All torque values are listed in foot-pounds K = 0.17 for zinc plated, dry conditions F = Clamp Load
 Torque values calculated from formula T=KDF, where K = 0.20 for plain and dry conditions

* These are intended to be general specifications. See tractor operators or service manual for exact specifications for your unit.

MAINTENANCE

LUBRICATION RECOMMENDATIONS

Description	Application	General Specification	Recommended Mobil Lubricant
Tractor Hydraulics	Reservoir	JD-20C MF M1135,M1141 FNHM2C134D (FNH201)	Mobilfluid 424
Mower Hydraulics	Reservoir		
Cold Temperatures 0 F Start-Up		ISO 46 Anti-Wear - Low Temp	Mobil DTE 15M
Normal Temperatures 10 F Start-Up		JD-20C MF M1135,M1141 FNH M2C134D (FNH201)	Mobilfluid 424
Normal Temperatures 15 F Start-Up		ISO 46 Anti-Wear	Mobil DTE 25
High Operating Temp. Above 90 F		ISO 100 Anti-Wear	Mobil DTE 18M
Flail Rear Gearbox	Grease	PAO Synthetic Extreme Pressure Gear Lube	Mobil SHC 75W-90 Mobil 1 Synthetic Gear
Cutter Shaft & Ground	Grease	Lithium-Complex	Mobilgrease CM-S
Roller Shaft (Flail)	Gun	Extreme Pressure NLGI 2 - ISO 320	
Drive Shaft Coupler (Flail and Rotary)	Grease Gun	Lithium-Complex Extreme Pressure NLGI2 - ISO 320	Mobilgrease CM-S
Drive Shaft Yoke, U-Joint & Stub Shaft	Grease Gun	Lithium-Complex Extreme Pressure NLGI2 - ISO 320	Mobilgrease CM-S
Boom Swivel	Grease	Lithium-Complex	Mobilgrease CM-S
Boom Cylinder Pivots (Rotary & Flail Boom)	Gun	Extreme pressure NLGI2 - ISO 320	
Deck Boom Pivot & Deck Stop Adjustment (Rotary & Flail)	Grease Gun	Lithium-Complex Extreme pressure NLGI 2 - ISO 320	Mobilgrease CM-S
Deck Spindle (Rotary)	Grease Gun	Tiger Spindle Lubricant part number 06540000	Mobilith SHC 220

MAINTENANCE

POLYCARBONATE CARE & MAINTENANCE

The proprietary UV and Abrasion Resistant surface coating on SHIELDS® SUPERCOATED™ polycarbonate significantly improves performance. Periodic cleaning using proper procedures and compatible cleaners are recommended to prolong service life. Tiger Corp. polycarbonate is SUPERCOATED™ on both sides.

CLEANING THE SUPERCOAT™ HARD-COAT

1. Wash with a mild solution of soap or detergent and lukewarm water.
2. Using a soft cloth or sponge, gently wash the sheet to loosen dirt and grime and rinse well with clean water.
3. To prevent water spotting, thoroughly dry with chamois or cellulose sponge.
4. Avoid the use of abrasive cleaners, squeegees and/or other cleaning implements that may mar or gouge the coating.

CLEANING AGENTS WHICH HAVE BEEN FOUND TO BE COMPATIBLE UNDER LABORATORY CONDITIONS:

- Aqueous Solutions of Soaps and Detergents
Windex¹ Top Job² Joy² Mr. Clean²
Fantastik³ Formula 409⁴ Sumalight D12 Brucodecid
- Organic Solvents
Butyl Cellosolve Kerosene Hexel, F.O. 554 Naphtha (VM&P grade)
Neleco-Placer Turco 5042
- Alcohols
Methanol Isopropyl

All residual organic solvents should be removed with a secondary rinse.

GRAFFITI REMOVAL

Butyl cellosolve (for removal of paints, marking pen inks, lipstick, etc.). The use of masking tape, adhesive tape or lint removal tools works well for lifting off old weathered paints.

To remove labels, stickers, etc., the use of kerosene or VM&P naphtha are generally effective. When the solvent will not penetrate sticker material, apply heat (hair dryer) to soften the adhesive and promote removal.

IMPORTANT: If a material is found to be incompatible in a short-term test, it will usually be found to be incompatible in the field. The converse, however, is not always true. Favorable performance is no guarantee that actual end-use conditions have been duplicated. Therefore, these results should be used as a guide only and it is recommended that the user test the products under actual end-use conditions.

MAINTENANCE

RECOMMENDED FILLING INSTRUCTIONS FOR HYDRAULIC RESERVOIRS

When filling or checking the oil level, the unit should be parked on a level surface, shut **"OFF"**, and allowed sufficient time to cool to ambient temperature. Use caution when removing the pressurized breather. Do not place face over opening when removing the breather.

The reservoir should be filled to the top of the lower sight glass on the side of the tank. Do not over-fill. The reservoir has been over-filled when oil is visible in the upper sight glass. If tank has too much oil, the excess may be expelled through the pressurized breather.

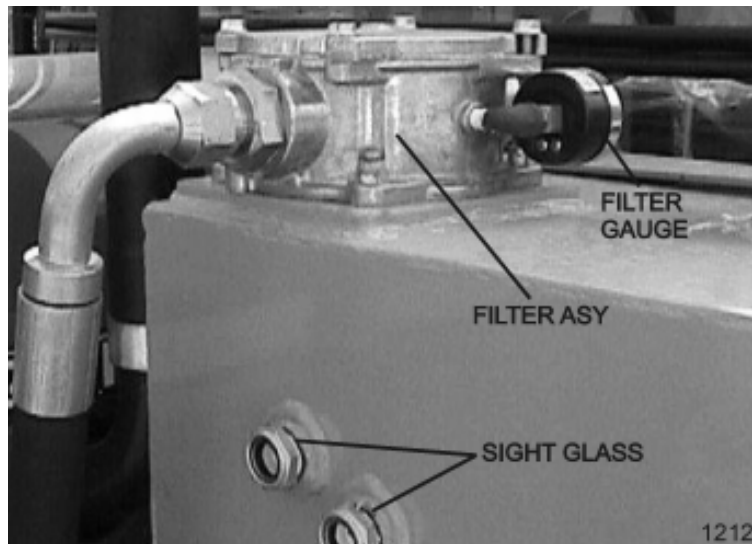

DETAILED MAINTENANCE

REPLACING IN-TANK HYDRAULIC FILTER:

Loosen the four bolts on the top cover of the filter housing. Turn cover counter-clockwise until cover is free. Remove and replace filter. Replace top cover and cover bolts in opposite order as removed.

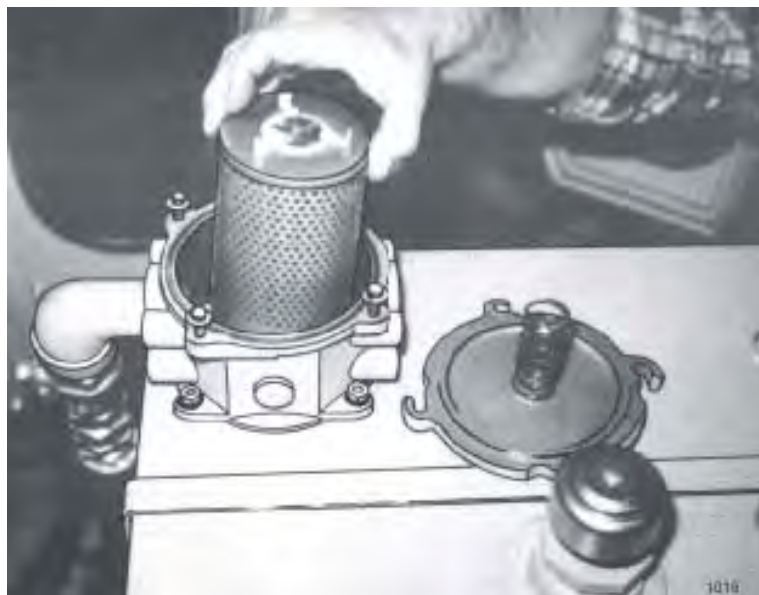

MAINTENANCE

DETAILED MAINTENANCE

REPLACING HIGH PRESSURE HYDRAULIC FILTER ELEMENT:

Assure system has been shut down and de-pressurized. Locate High Pressure Filter housing. Confirm that the element that is about to be installed matches the element p/n on the filter model tag. Example: V3.0510-06 (world line 100, HD049 model) Locate the bottom of the High Pressure Bowl, and use the appropriate spanner wrench –or- ratchet that matches the hex pattern. Using the spanner wrench -or- ratchet and turning in a counterclockwise rotation, (looking at the bottom of the bowl) remove the bowl from the head, The first couple rotations will seam tight as the o-ring passes the sealing flats, once the o-ring has cleared the sealing flats the bowl should spin freely. Taking care not to drop the bowl, finish removing the bowl from the head. **WARNING:** bowl will be full of oil! Pour the oil from the bowl into a container, this oil should be considered contaminated due to the flow direction through the element is outside ~ in. Clean the inside of the bowl if “dirt” is present. Remove the old element from the filter head by pulling with a rotation motion. Dispose of the used element properly. Remove the new element from the packaging. Using your finger, dab and lubricate the o-ring in the top of the new element. Install the new element into and on the mounting boss with in the head; assure that the element is fully seated on the boss. Clean and inspect the o-ring that is affixed in the bowl, lubricate with oil. Using a clockwise rotation, screw the bowl back into the head, assuring that the bowl has not been cross threaded into the head. Continue “tighten” the bowl into the head, using the spanner wrench –or- ratchet, the rotation of the bowl will become tighter once the o-ring engages the sealing flats. Once the bowl has been fully inserted into the head, and the o-ring has reached the sealing flats, the bowl can no longer be “tightened” and bottoms out. Once the bowl has bottomed out, “back-off” the bowl by 1/6 turn, this assures that the o-ring is seated properly with in the sealing flats. Element change out and re-assembly is now complete. Start the machine and inspect the filter area checking that there is no oil leaking from the filter assembly. This is first to be done at 50 hours of operation, then yearly(500 hours) or when indicated by restriction indicator.

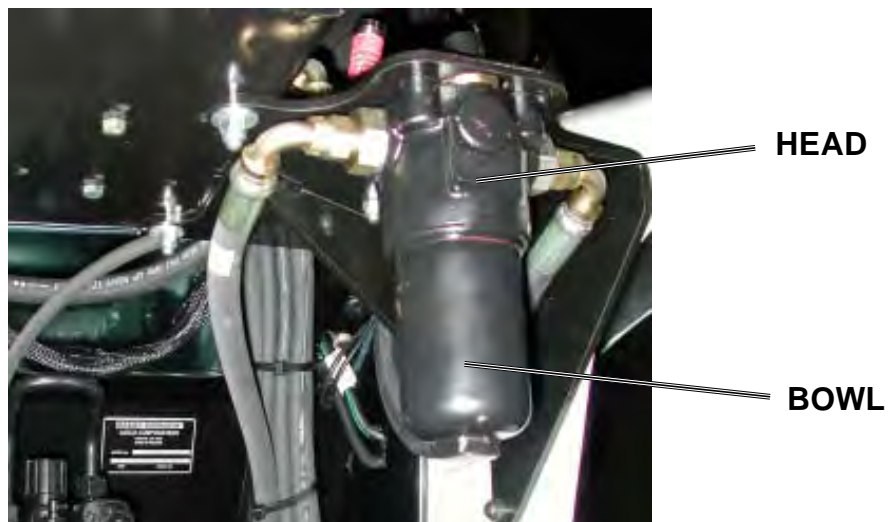

MAINTENANCE

GREASING INNER AND OUTER DRAFT BEAM PIVOT POINTS

Locate the grease zerks on the inner and outer draft beam pivot bosses. Inject Lithium-Complex Extreme Pressure grease conforming to NLGI2-ISO 320 specifications into each zerk until grease protrudes from joints. Grease all pivots daily or every 8 hours of service.

GREASING THE UPPER AND LOWER SHEAVES

Locate the grease zerks on the ends of the upper and lower sheave pins as shown below. Inject Lithium-Complex Extreme Pressure grease conforming to NLGI2-ISO 320 specifications into each pin until it protrudes from the ends. These should also be greased daily or for every 8 hours of service.

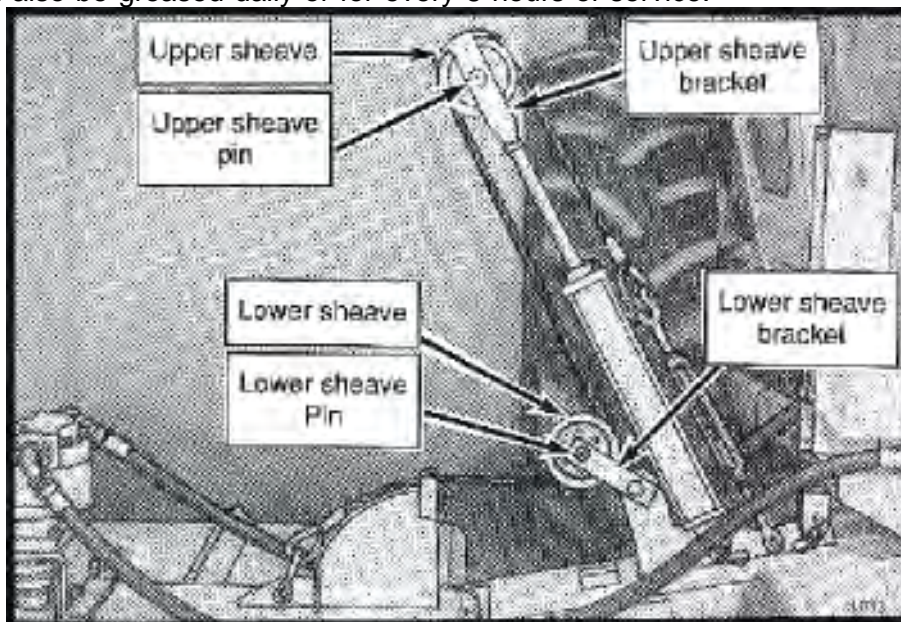

GREASING INNER AND OUTER DRAFT BEAM PIVOT POINTS

Locate the grease zerks on the inner and outer draft beam pivot bosses. Inject Lithium-Complex Extreme Pressure grease conforming to NLGI2-ISO 320 specifications into each zerk until grease protrudes from joints. Grease all pivots daily or every 8 hours of service.

MAINTENANCE

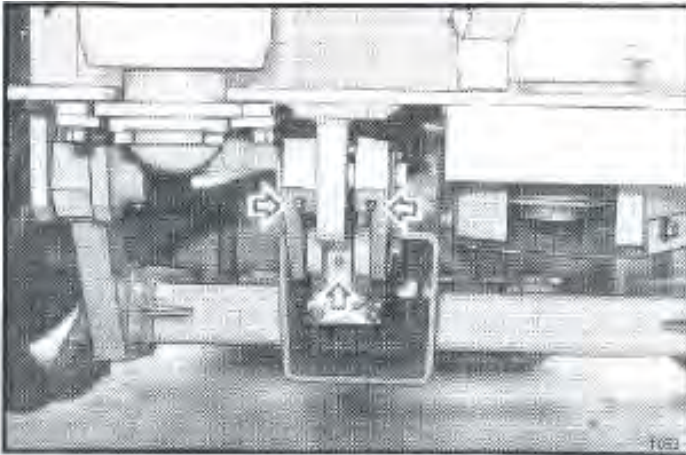
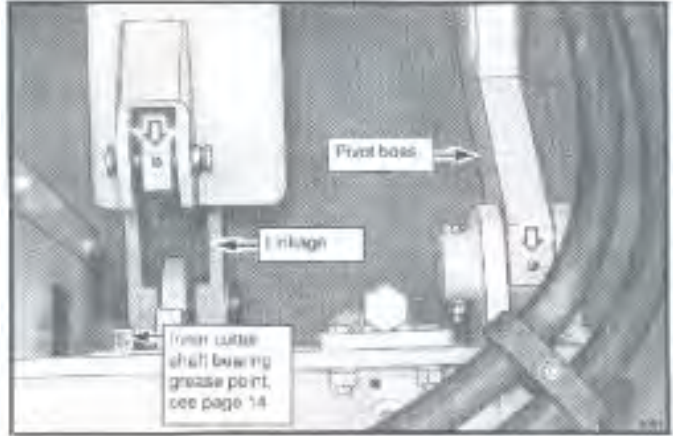

With the cutter head lowered, locate the grease zerks on the linkage and pivot bosses. Inject Lithium-Complex Extreme Pressure grease conforming to NLGI2-ISO 320 specifications until it protrudes from the ends. With the cutter head in this position it is also possible to grease the draft beam cylinder anchors and pins. Now raise the cutter head to expose the remaining zerks on the deck tilt linkages and on the other end of the cylinder.

TIGHTENING KNIFE BOLTS AND DISK BOLTS:

After every 8 hours of operation or daily, the Knife Bolts and Disk Bolts should be tightened as follows:

Knife mounting bolts (2ea.) torque oiled to 800 ft. lbs.

Disk mounting bolts (6ea.) torque dry to 204 or oiled to 184 ft. lbs.

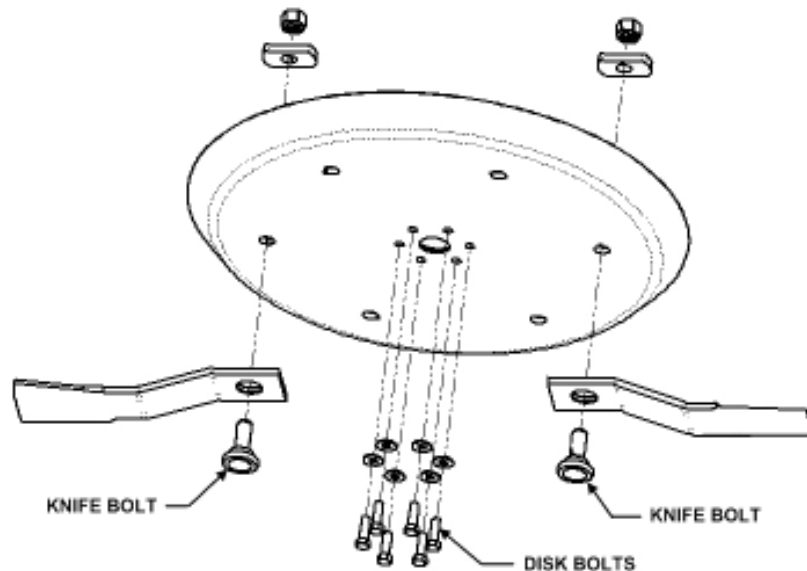

MAINTENANCE

GREASING PUMP DRIVE SHAFT COUPLER:

With engine stopped, ensure drive shaft alignment by grasping coupler and sliding back and forth. Coupler should slide freely with approximately 1/8" of end play. If coupler does not slide freely, inspect for loose pump mount bolts, or damaged or loose crank shaft adapter. Inject Lithium-Complex Extreme Pressure grease conforming to NLGI2-ISO 320 specifications into coupler until grease begins to protrude from ends. Grease daily or every 8 hours. Do not over grease.

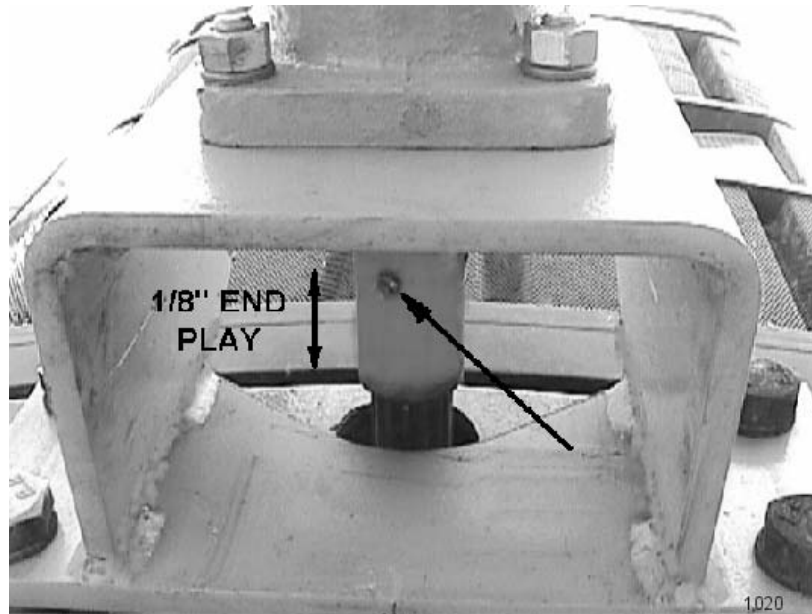

DRIVE SHAFT YOKE, U-JOINT & STUB SHAFT

With engine stopped, inject Lithium-Complex extreme pressure grease conforming to NLGI2-ISO 320 specifications into universal joints and slip yoke until grease appears at the seal. Grease them daily or every 8 hours.

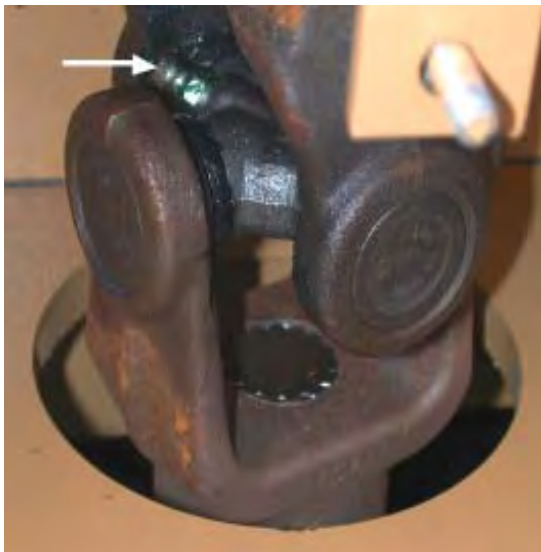

MAINTENANCE

ADJUSTING THE CABLE LIFT

Extend the outboard cylinder until the mower deck touches its stop on the draft beam as shown. NOTE: Make sure the cable turnbuckle is loose enough to allow the cylinder to reach full extension before the head reaches the stop. Now hold the head against the stop and tighten the turnbuckle until the cable is tight. Lower and raise the head to check the adjustment. The head should touch its stop at the same time the cylinder reaches full extension. Tighten turnbuckle lock nuts securely after adjustment is complete.

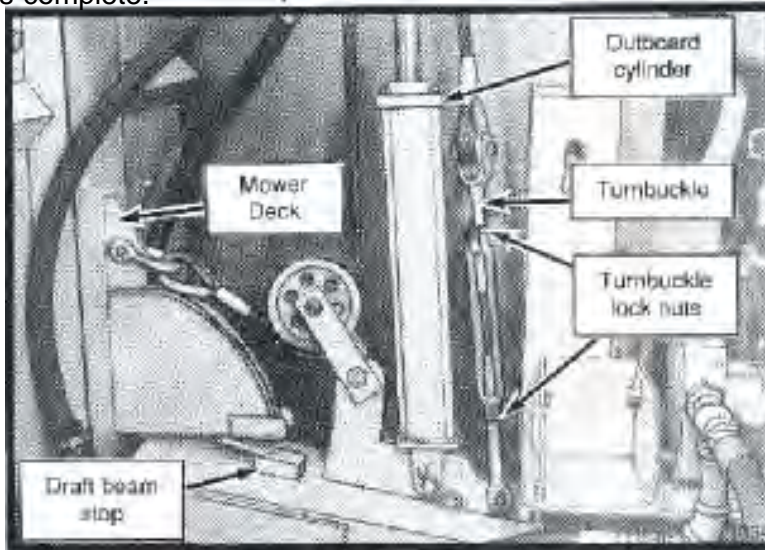

BALL VALVES

The ball valve at the hydraulic reservoir may need to be closed during certain maintenance or repair procedures. **THE BALL VALVES MUST BE OPEN (handle parallel with valve) WHEN TRACTOR IS RE-STARTED OR PUMP IS COUPLED TO MOTOR OR P.T.O. !** Failure to do so may result in component failure!

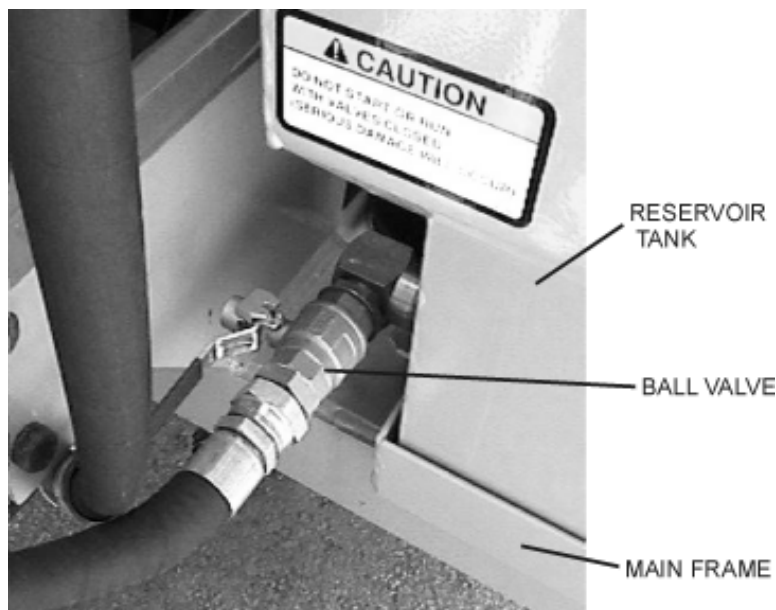

1211

MAINTENANCE

GREASING SPINDLE

Locate grease fitting on inside of deck housing. Inject Tiger Spindle Lubricant, part number 06540000 into spindle housing. Fill with lubricant until lubricant weeps out of the top spindle seal. Lubricate spindle weekly or every 40 hours of use.



TIGHTENING SPINDLE BOLTS

The spindle mounting bolts should be checked and retorqued daily or every 10 hours of service. Torque the (6) bolts shown below to 331 ft. lbs.



MAINTENANCE

GREASING MOTOR SPLINE TO SPINDLE SPLINE

Locate motor spline and spindle spline on the mower deck. Grease splines with Mobil moly 52. Use about 4 ounces of grease. Change grease yearly or every 500 hours.

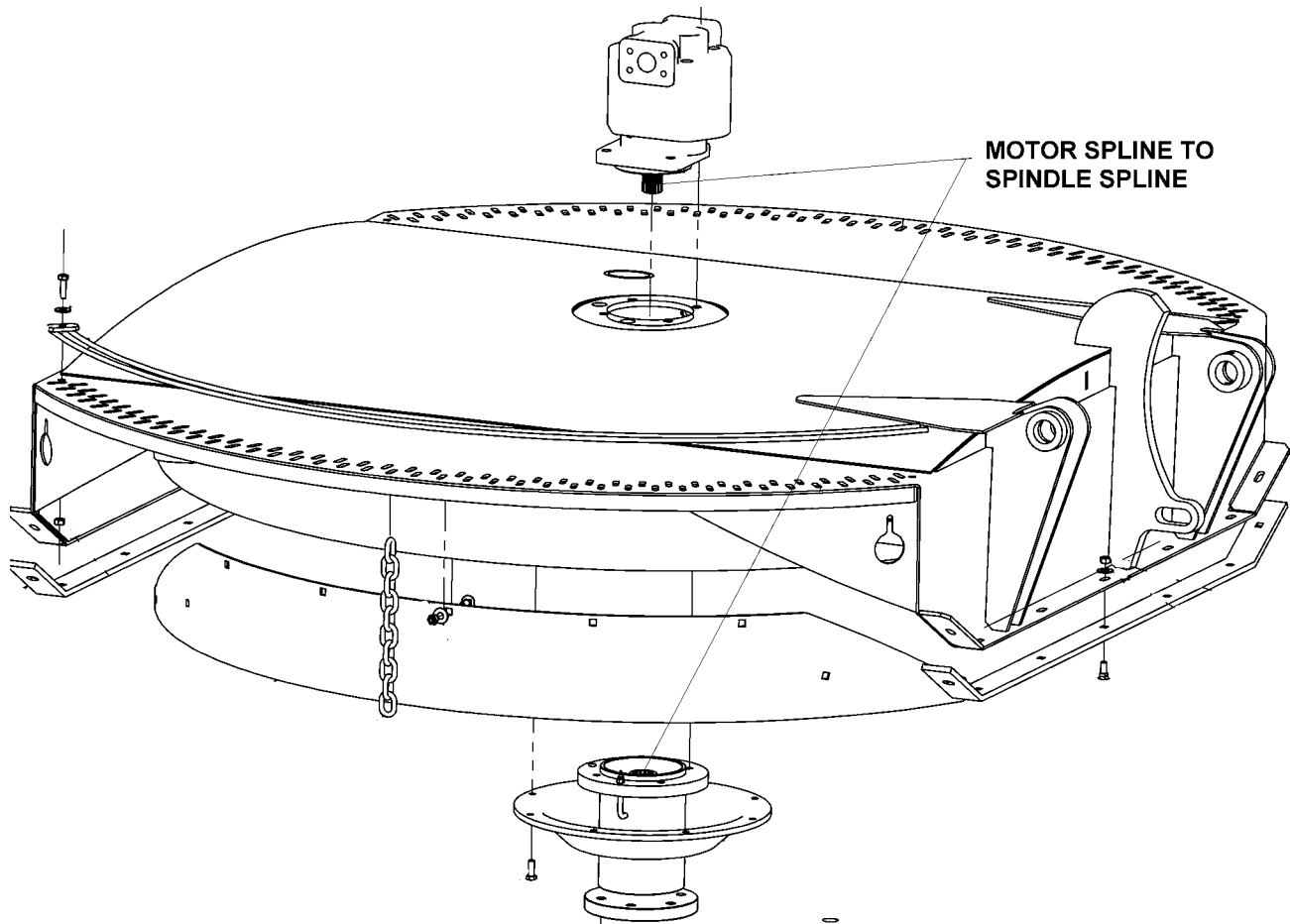

MAINTENANCE

INSPECTION OF ROTARY KNIVES

CAUTION!



Failure to follow the following warnings and instructions may result serious injury or damage to the equipment or property!

- 1 – **DO NOT** weld on the knife or bolts. Damaged or worn knives must be replaced.
- 2 – Knife must be replaced in sets. Knives with unequal wear may cause serious vibration and resulting structural damage to the mower.
- 3 – The self-locking nuts for the knife mounting bolts must **NOT** be reused. If the self-locking nut is removed from the knife mounting bolt, the nut **must** be replaced with a new self-locking nut.
- 4 – Inspect the condition and tightness of the knife mounting bolts and disk mounting bolts daily.

ROTARY KNIFE REPLACEMENT

- 1 – Be sure you have a complete matching set of new knives for replacement.
- 2 – Remove knives and inspect holes for damage. Also watch for cracks in the disk around the holes.
- 3 – Lube threads with anti-seize, motor oil or grease. Install bolt through knife and disk from bottom side of disk. Install new self-locking nuts and torque them to 800 oiled ft. lbs.
- 4 – The knives should swing freely to absorb shocks from impact when striking objects.

WARNING!



WHEN CUTTING HEAVY BRUSH, KNIFE BOLTS SHOULD BE INSPECTED HOURLY AND RETORQUED TO 1070 dry or 800 oiled FT. LBS.

MAINTENANCE

REPLACEMENT OF ROTARY DISK

CAUTION!



Failure to follow the following warnings and instructions may result in serious injury or damage to the equipment or property!

The bolts that attach the knife mounting disk to the spindle must be grade 8. These 5/8 inch bolts are to be torqued to 204 dry or 184 oiled ft. lbs.

A thread locking agent may be applied to threads of all mounting bolts before they are installed.

Disks must be inspected daily for hairline cracks between spindle mounting bolts or around the knife mounting bolts. These cracks indicate metal fatigue caused by severe abuse. If cracks are present, the disk must be replaced.

Inspect the disk mounting bolts daily when checking tightness of blade mounting bolts. If a disk mounting bolt is loose, it must be removed, threads cleaned, fresh thread locking agent applied, and tightened to proper torque value.

If a knife mounting bolt is loose, the self locking nut must be replaced as a safety precaution. Lubricate threads with anti-seize, grease or motor oil. Place bolts through knife and disk from bottom side of disk. Install self locking nuts and torque them to 800 ft. lbs.

1- WARNING: The disk alone weighs approximately 210 lbs. Be sure its weight can be supported before attempting to replace. The use of a lift mechanism will ease replacement.

2- Remove the six disk mounting bolts and the disk from the spindle.

3- Install new disk and align with mounting bolt holes.

4- Apply a thread locking agent to all of the mounting bolts and install the bolts through the disk. If a bolt protector is being installed, hold the protector in place and install the bolts through the bolt protector and disk. **NOTE:** Disk bolts must be Grade 8.

5- Tighten bolts down and torque to values noted.

6- See knife replacement instructions for replacing the knives onto the new disk.

MAINTENANCE

HEAVY DUTY SPINDLE ASSEMBLY INSTALLATION AND BEARING ADJUSTMENT

WARNING! A press **MUST** be used to install bearing cups, bearing cones, and seals. **DO NOT** use a hammer to install races, bearings, or seals. The parts of assembly may be damaged.

NOTE: The grease zerk and gussets are located on the top side of the spindle housing. Be sure the spindle is assembled correctly.

Be sure to wear eye protection and other protective equipment as needed when working on spindle assembly.

THE SPINDLE ASSEMBLY

See the diagram below for identification of spindle parts, while servicing.

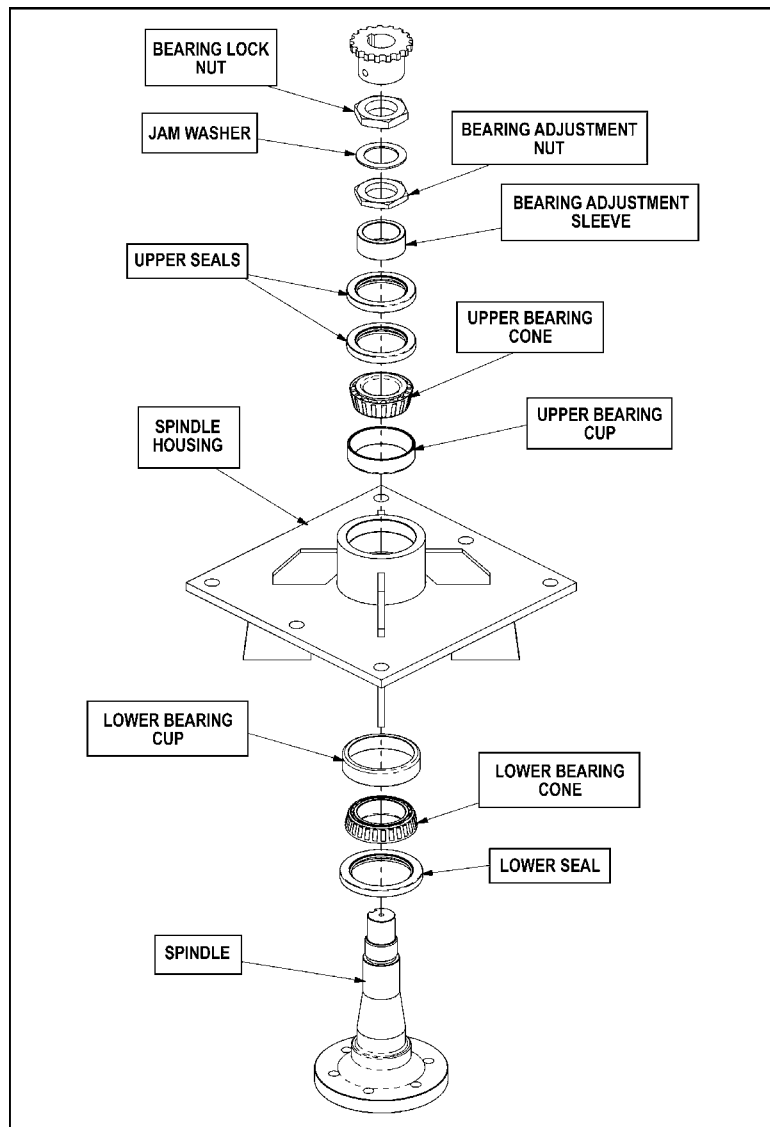

MAINTENANCE

BEARING INSTALLATION

- 1 – Press upper bearing cup into the spindle housing.
 - 2 – Turn the spindle housing over and press in the lower bearing cup.
 - 3 – Place the lower bearing cone in the bearing cup. Next press the seal into the spindle housing. The inner lip of the seal must be DOWN, towards the bearing, so lubricant is sealed inside the housing.
 - 4 – Install the spindle in the housing. Lightly press the spindle to seat the cone onto the spindle.
 - 5 – Support the bottom of the spindle and press the upper bearing cone and bearing adjustment sleeve onto the spindle.
- NOTE:** The spindle housing must turn freely when seating the bearing cone and sleeve.
- 6 – Press the two upper seals into the spindle housing. The inner lip of the seals must be UP, away from the bearing, so excess lubricant can escape.
 - 7 – Install the bearing adjustment nut (thin nut) so there is 1/16" clearance between the nut and the sleeve. Install the jam washer, placing the tab into the key-way. Install the bearing lock nut (thick nut) and hand tighten against jam washer and adjustment nut. See the following section for bearing adjustment.
 - 8 – Position the spindle housing horizontally with the drain hole oriented "up." Grease through the zerk with Tiger Spindle Lubricant(part number 06540000) until the grease purges from the drain hole.
 - 9 – Install the plug into the drain hole.

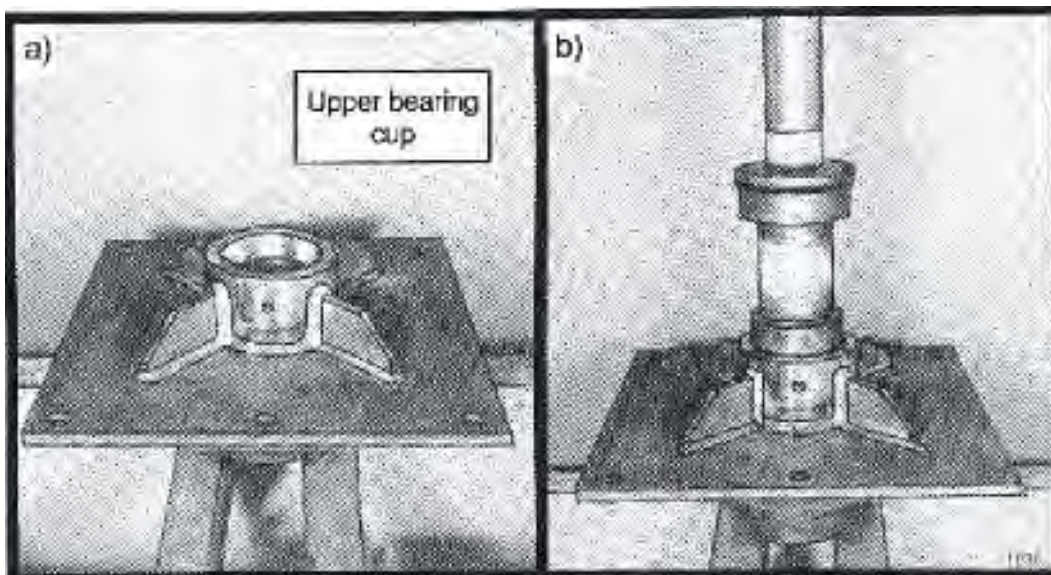

MAINTENANCE

BEARING ADJUSTMENT

- 1 – Clamp the bottom end of the spindle securely in a vise so the spindle housing turns freely.
- 2 – Position a magnetic base dial indicator on the outer diameter of the spindle housing. Locate the end of the dial indicator against the flat end of the spindle shaft. The dial indicator will now measure accurately bearing end play.
- 3 – Tighten the bearing adjustment nut until there is .012 inch movement when the spindle housing is pried upward away from the vise jaws.
- 4 – When there is .012 inch free play between the spindle and housing, install the bearing lock nut (thick nut). Hold the adjusting nut securely and tighten the lock nut to 300 ft. lbs. of torque.
- 5 – After the lock nut is tightened, there must be .001 inch to .003 inch of free play when lightly prying up on the spindle housing.

If the end play is correct, .001 inch to .003 inch, bend tabs up on jam washer to prevent the lock nut from loosening.

If the end play is NOT correct, loosen the lock nut and turn the adjustment nut as required and re-tighten the lock nut. Repeat first part of step 5.

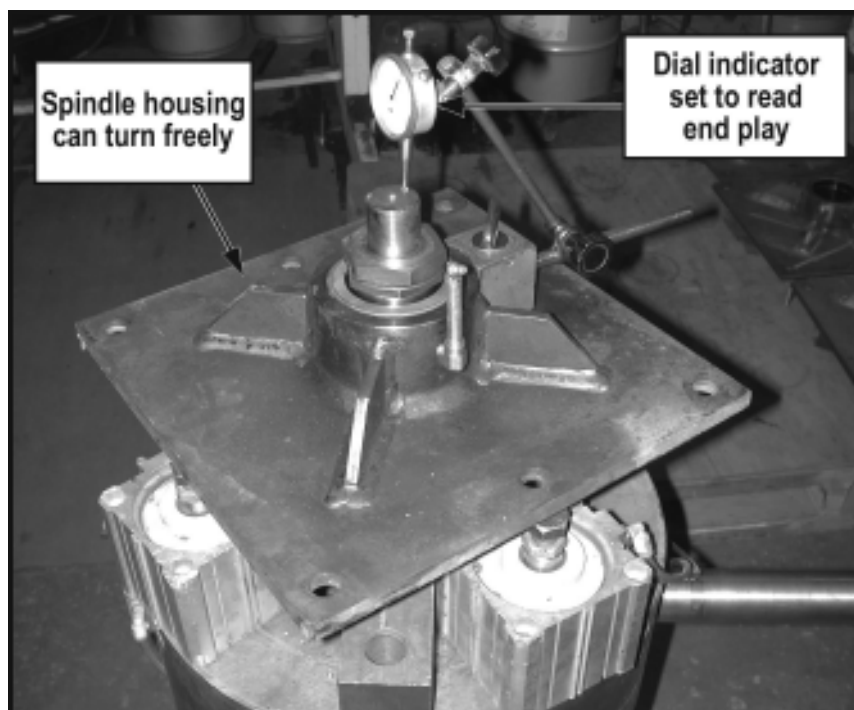

MAINTENANCE

DAILY MAINTENANCE SCHEDULE

The following services should be performed **daily** or every **8 hours** of service, following the detailed maintenance instructions in the operators manual.

- _____ Pump Drive Shaft: Check for end play in drive shaft / coupler and lubricate at zerks.
- _____ Crankshaft adapter: If equipped with rubber grommets check condition, replace if missing or damaged.
- _____ Pivot points: Inject grease until it appears at ends.
- _____ Hydraulic fittings: Check for leaks with paper or cardboard. Tighten fittings or replace hoses immediately.
- _____ Knives: Inspect for missing or damaged knives, change (only complete sets) as needed.
- _____ Belts: Check / Tighten / Replace belts as needed.
- _____ Main Frame / Deck: Unless otherwise specified retorque bolts according to torque specifications in this section.
- _____ Hydraulic Fluid Level: Add, if required, per fluid recommendations.
- _____ Rear Flail Drive, Bearing
Flange and Shaft Couplers: Grease as instructed in the detailed (if applicable) maintenance section.
- _____ Cutter Shaft and Ground Roller: Grease as instructed in the detailed maintenance section

Service performed by: _____ Date: ____/____/____ Hour
Meter: _____

Maintenance Section

** This page may be copied and used as part of the daily maintenance routine.

MAINTENANCE

SIDE ROTARY

KUBOTA M105X

**PARTS
SECTION**

PARTS ORDERING GUIDE

The following instructions are offered to help eliminate needless delay and error in processing purchase orders for the equipment in this manual.

1. The Parts Section is prepared in logical sequence and grouping of parts that belong to the basic machine featured in this manual. Part Numbers and Descriptions are given to help locate the parts and quantities required.

2. The Purchase Order must indicate the **Name and Address** of the person or organization ordering the parts, **who should be charged**, and if possible, the **serial number of the machine** for which the parts are being ordered.

3. The purchase order must clearly list the **quantity of each part**, the complete and correct **part number**, and the basic **name of the part**.

4. The manufacturer reserves the right to substitute parts where applicable.

5. Some parts may be unlisted items which are special production items not normally stocked and are subject to special handling. Request a quotation for such parts before sending a purchase order.

6. The manufacturer reserves the right to change prices without prior notice.

NOTE: When ordering replacement decals, refer to the part numbers and descriptions listed in the safety section in the front of this manual.



1000

For maximum safety and to guarantee optimum product reliability, always use genuine **Tiger** replacement parts. The use of inferior replacement parts may cause premature or catastrophic failure which could result in serious injury or death.

Direct any questions regarding parts to:

Tiger Corporation
3301 N. Louise Ave.
Sioux Falls, SD 57107
1-800-843-6849
1-605-336-7900

PARTS SECTION TABLE OF CONTENTS

SECTION	ASSEMBLY	PAGE
TRACTOR SPECIFIC PARTS:		
TRACTOR MNT. KIT - MAIN FRAME M105X	06101300	5-4
TRACTOR MOUNT KIT - HYDRAULICS M105X	06101300	5-6
COMBO DRAFT BEAM		5-8
2SP HUSCO CONTROLS - KUBOTA M105X		5-10
2SP HUSCO LIFT VALVE - COMBO	06101302	5-12
2SP HUSCO LIFT VALVE - CABLE	06101312	5-14
HUSCO VALVE BREAKDOWN	30801	5-16
HUSCO VALVE BREAKDOWN	31752	5-18
SAFETY SCREEN - KUBOTA M105X	06101307	5-20
OPTIONAL PUMP GUARD KIT	06200342	5-22
OPTIONAL PUMP AND GRILL GUARD KIT	06200349	5-23
FUEL TANK - KUBOTA M105X	06101300	5-24
SWITCH BOX SCHEMATIC	06510102	5-25
SOLENOID BRAKE VALVE ASSEMBLY	34115	5-26
SOLENOID BRAKE VALVE HYDRAULIC SCHEM.	34115	5-27

TRACTOR MOUNT KIT - MAIN FRAME M105X

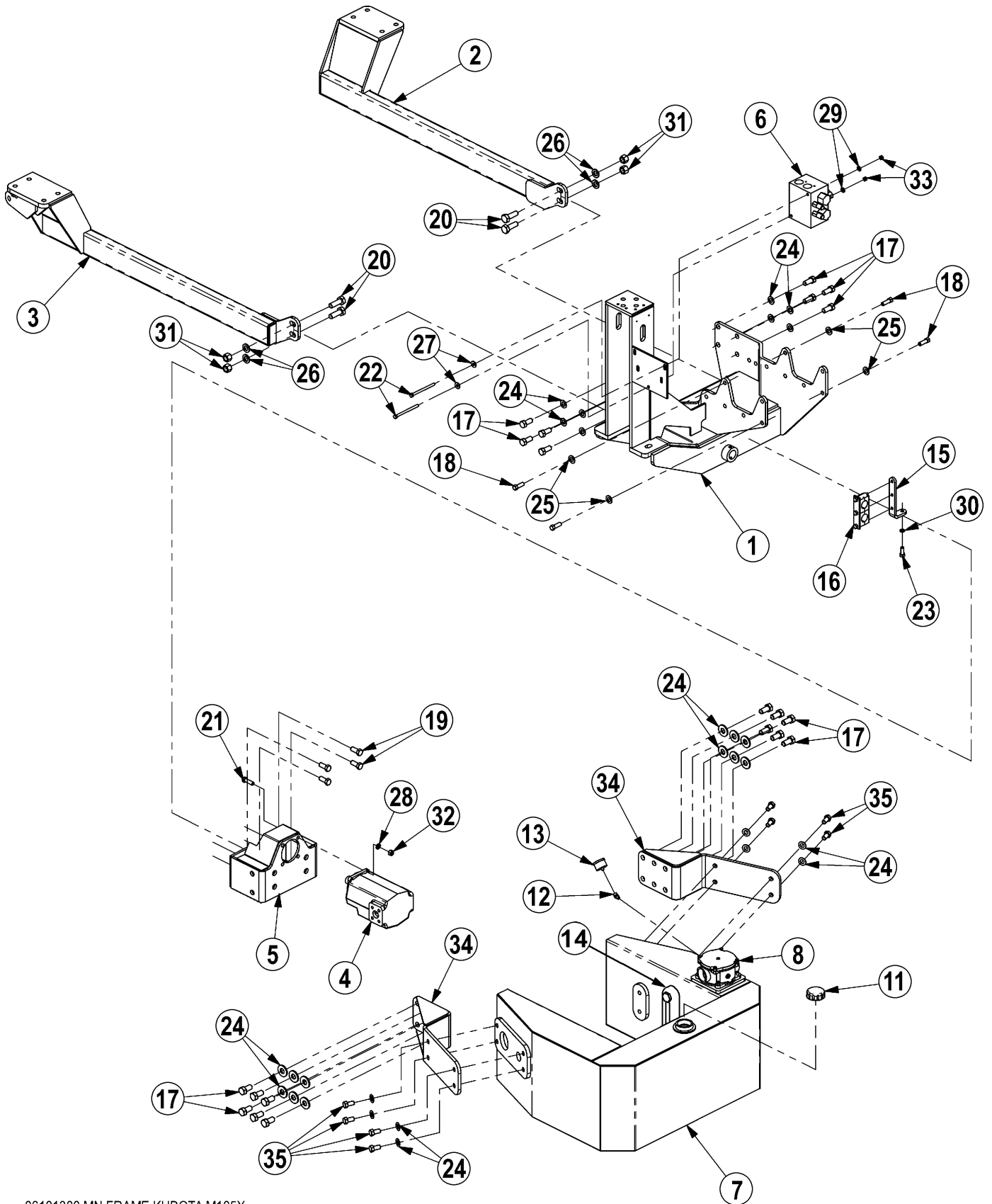

06101300 MN FRAME KUBOTA M105X

TRACTOR MOUNT KIT - MAIN FRAME M105X

ITEM	PART NO.	QTY.	DESCRIPTION
1	06300043	1	MNFRM,KUB,M105X
2	06300044	1	AXL BRC,LH,KUB,M105X
3	06300045	1	AXL BRC,RH,KUB,M105X
4	23152	1	PUMP,P350-1 3/4 GEAR
5	06380026	1	PUMP MNT,KUB,M105S
6	06510083	1	VALVE,BRAKE,SOL,3000PSI,METRI
	34666	*	TANK,RES,BUMP,BLANK,CPLT,ASSY
7	33695	1	TANK,RES,BUMPER,BLANK
8	35269	1	FILTER ASSY,IN-TANK,JIC,10MIC
10	21627	4	NYLOCK NUT,3/8 NC
11	06505077	1	CAP,PRESSURE,3.0PSI
12	TF4887	1	STREET ELBOW,1/8 X 45
13	6T0649	1	FILTER GAUGE
14	06505067	1	SIGHT GLASS,TANK
15	06410394	1	MOUNT,HOSE CLAMP
16	35131	1	CLAMP KIT,COOLER,TRUCKAT
*17	06530531	20	CAPSCREW,18MMx40MM(1.5P)GR8.8
18	06530530	12	CAPSCREW,M14xM55(1.5P),GR 8.8
19	6T2521	4	CAPSCREW,16MMX40MM(1.5 PITCH)GR8.8
20	21833	4	CAPSCREW,3/4 X 2-1/4 NC
21	21732	4	CAPSCREW,1/2 X 1-3/4 NC
22	21644	2	CAPSCREW,3/8 X 5 NC
23	21730	1	CAPSCREW,1/2 X 1-1/4 NC
24	33764	32	FLATWASHER,5/8,GR 8,SAE
25	06533003	12	FLATWASHER,9/16 GR 9 SAE
26	33880	4	FLATWASHER,3/4,GR 8,SAE
27	22016	2	FLATWASHER,3/8
28	21990	4	LOCKWASHER,1/2
29	21988	2	LOCKWASHER,3/8
30	21989	1	LOCKWASHER,7/16
31	21825	4	HEX NUT,3/4 NC
32	21725	4	HEX NUT,1/2 NC
33	21625	2	HEX NUT,3/8 NC
34	06380025	2	TANK MNT,KUB,M105S
35	21780	8	CAPSCREW,5/8 X 1-1/4 NC

* - NOTE: TORQUE #18 CAPSCREWS TO **155 FT. LBS. - DRY & 122 FT. LBS. - LUBRICATED**. THESE ATTACH THE FRONT OF THE MAIN FRAME TO THE TRACTOR FRAME.

TRACTOR MOUNT KIT - HYDRAULICS M105X

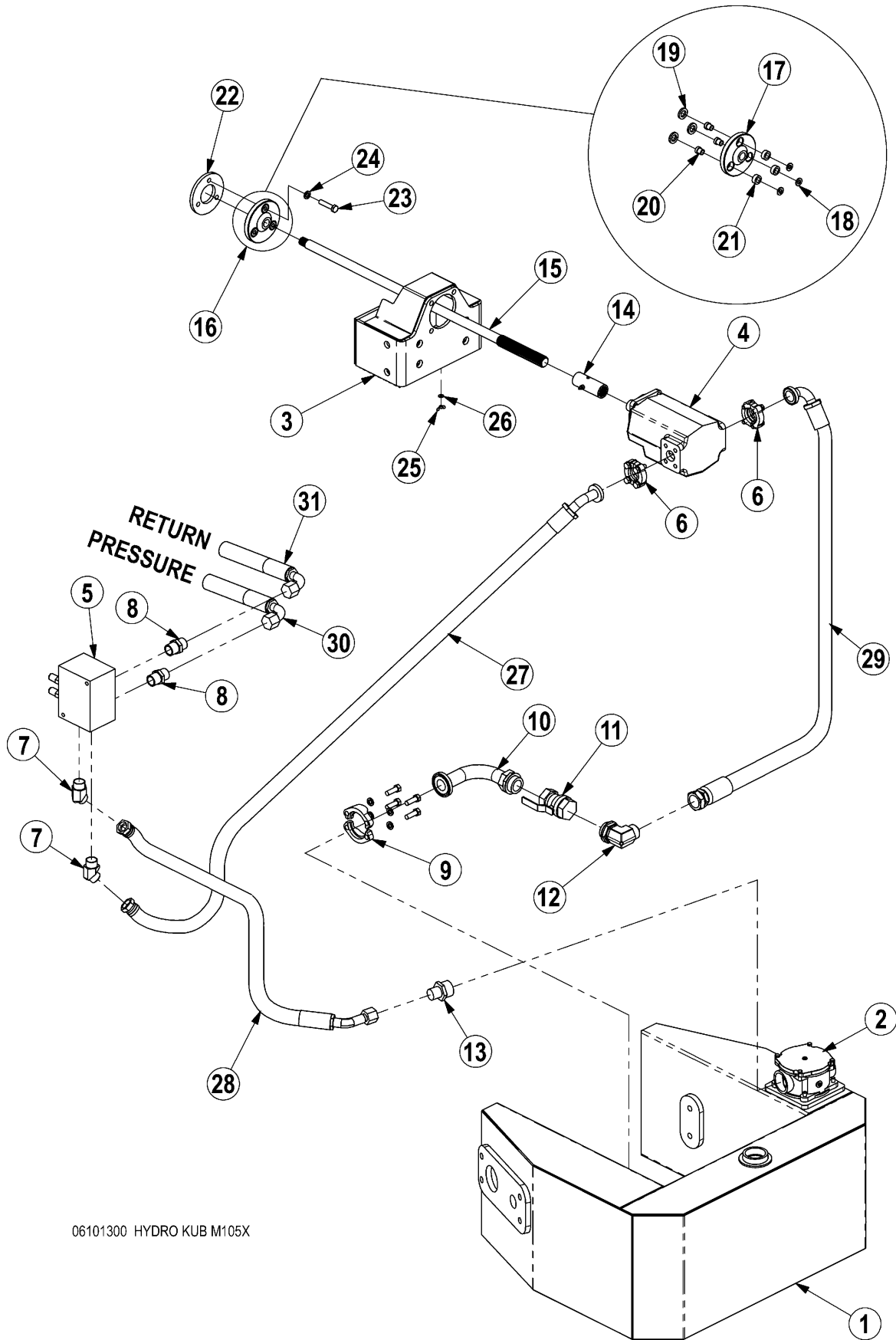

06101300 HYDRO KUB M105X

TRACTOR MOUNT KIT - HYDRAULICS M105X

ITEM	PART NO.	QTY.	DESCRIPTION
1	33695	1	TANK,RES,BUMPER,BLANK
2	35269	1	FILTER ASSY,IN-TANK,JIC,10MIC
3	06380026	1	PUMP MNT,KUB,M105S
4	23152	1	PUMP,P350-1 3/4 GEAR
5	06510083	1	VALVE,BRAKE,SOL,3000PSI,METRI
6	TF4852	2	KIT,FLANGE,#20
7	33554	2	ELBOW,1MORBX1MJIC,45
8	33555	2	ADAPTER 1" MORB X 1" MJIC
9	TF4431	1	KIT,FLANGE,#32
10	34389	1	ELBOW,1 1/2ORB X 32FLG90
11	34309	1	BALL VALVE,1 1/2 FOR
12	06503054	1	ELBOW,1 1/2 ORB x 1 1/4 MJ
13	34064	1	ADAPTER,1 1/4MOR X 1MJ
14	6T0375B	1	COUPLING,14 SPLINE,W/ZERK,4
15	06420045	1	DRV SHF,PMP,38.08,KUB
16	06700043	*	ADAPTER,CRANKSHAFT,KUB,M105X
17	6T0450	1	CRNKSHFT ADPT,KUB 7030
18	24937	3	FLATWASHER,7/16,SAE
19	06537004	3	WASHER,NEOPRENE,.75x1.25x.19
20	6T3202	3	GROMMET,STEEL,12MM
21	6T3218	3	GROMMET,RUBBER
22	06400393	1	SPACER,CRNKSHFT ADPTR,KUB,M105
23	24962	3	CAPSCREW,12MMX55MM(1.25 PITCH)
24	27724	3	LOCKWASHER,12MM
25	32519	1	NUT,WING,1/4-20 UNC
26	22014	1	FLATWASHER,1/4
27	06500248	1	HOSE,1x77(1FJX45x1FJX)
28	06500249	1	HOSE,1x92(1FJXx1FJX90)
29	06500214	1	HOSE,1 1/4x29(1 1/4FJXx20FLG90)
30	34161	1	HOSE,1X101 (60" CABLE LIFT)
*	34154	REF	HOSE,1X96 (60" COMBO LIFT)
*	34638	REF	HOSE,1X107 (72" CABLE OR COMBO LIFT)
31	34162	1	HOSE,1X98 (60" CABLE LIFT)
*	34155	REF	HOSE,1X96 (60IN COMBO LIFT)
*	34639	REF	HOSE,1X104 (72" CABLE OR COMBO LIFT)

NOTE:

1. Clamp the hose from the pump to the brake valve and the hose from the brake valve to the tank to the hose bracket.

2. Band hoses together with zip ties wherever loose. Where hoses may contact the frame or other edges, wrap with split hose and secure with hose clamps or zip ties.

COMBO DRAFT BEAM

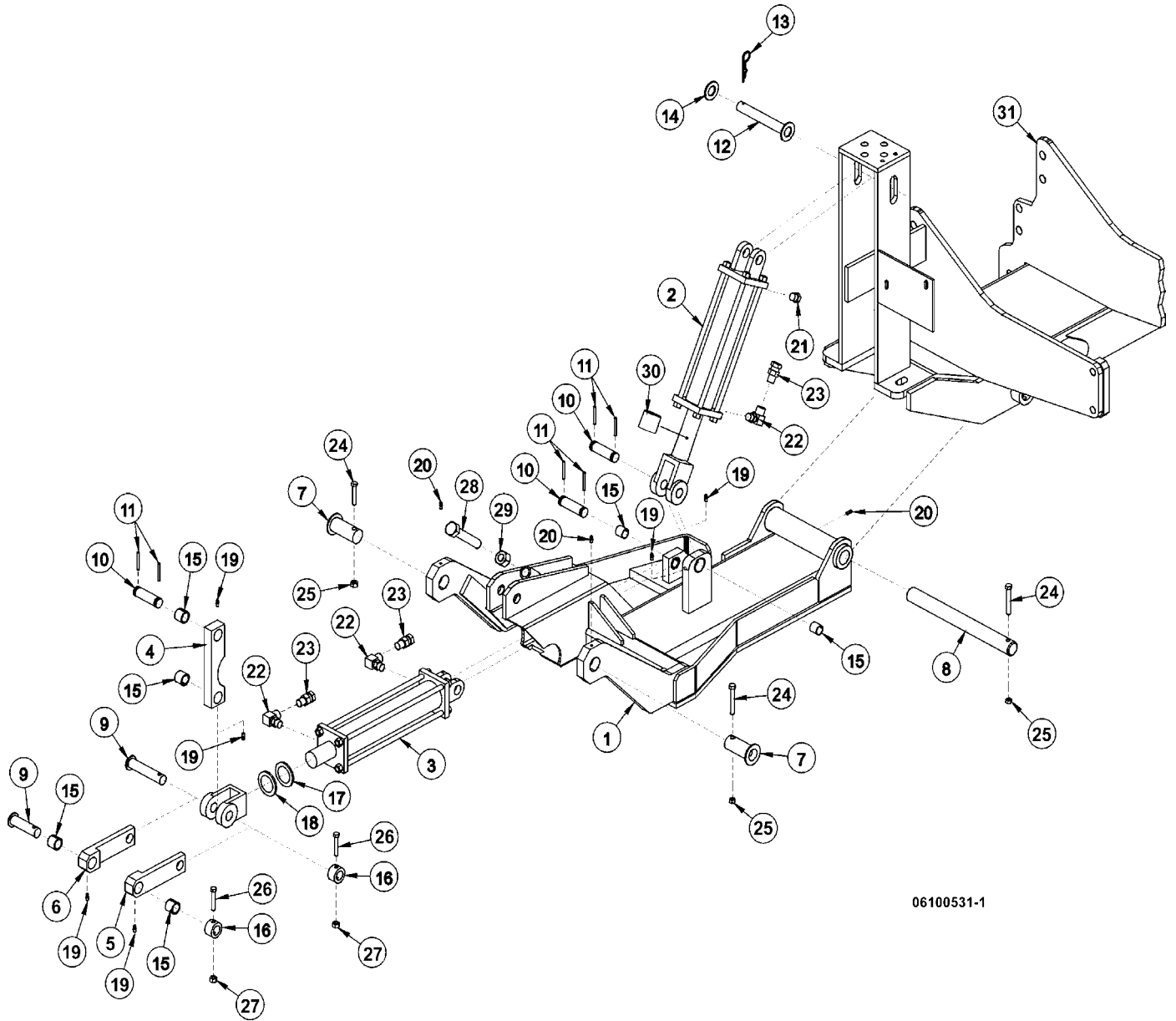

06100531-1

COMBO DRAFT BEAM

ITEM	PART NO.	QTY.	DESCRIPTION
1	32143	1	BEAM,DRAFT,JD5520-25
2	6T0151R	1	HYD. CYLINDER 3" X 10"
3	32215	1	HYD. CYLINDER 3" X 12"
4	TF4500A	1	PIVOT ARM
5	TF4507B	1	RIGHT LINKAGE ARM
6	TF4506B	1	LEFT LINKAGE ARM
7	30126B	2	PIN,DRAFT BEAM
8	6T3001	1	PIN, BEAM PIVOT
9	TF4519	2	PIN, LINKAGE
10	6T3003D	3	PIN, CLEVIS (DRILLED)
11	TB1023	6	ROLLPIN 7/32" X 2"
12	6T3002A	1	PIN, LIFT CYLINDER
13	6T3004	2	R-CLIP HAIRPIN
14	22023	2	FLATWASHER 1"
15	23724	8	BUSHING 1"
16	22847	2	BOSS, LINKAGE PIN
17	22076	1	SPACER, HYD. CYLINDER 1"
18	22077	1	SPACER, HYD. CYLINDER 1/2"
19	6T3207	5	GREASE ZERK 1/4"
20	6T3211	3	GREASE ZERK 1/8"
21	6T4258	1	BREATHER 1/2"
23	34244	3	ELBOW FITTING 1/2"
24	34396	3	SWIVEL RESTRICTOR
27	21688	3	CAPSCREW 7/16" X 3 1/4"
29	21677	3	NYLOCK NUT 7/16"
30	21635	2	CAPSCREW 3/8" X 2 1/4"
31	21627	2	NYLOCK NUT 3/8"
33	21831	1	CAPSCREW 3/4" X 1 3/4"
34	21825	1	HEX NUT 3/4"
35	30781	1	CYLINDER SPACER W/SET SCREW
36	*	REF	REFER TO MAIN FRAME

NOTE:

ITEM 35 IS USED ON THE GLAND END OF ITEM 2 (AS NEEDED)

2 SPOOL HUSCO CONTROLS - KUBOTA M105X

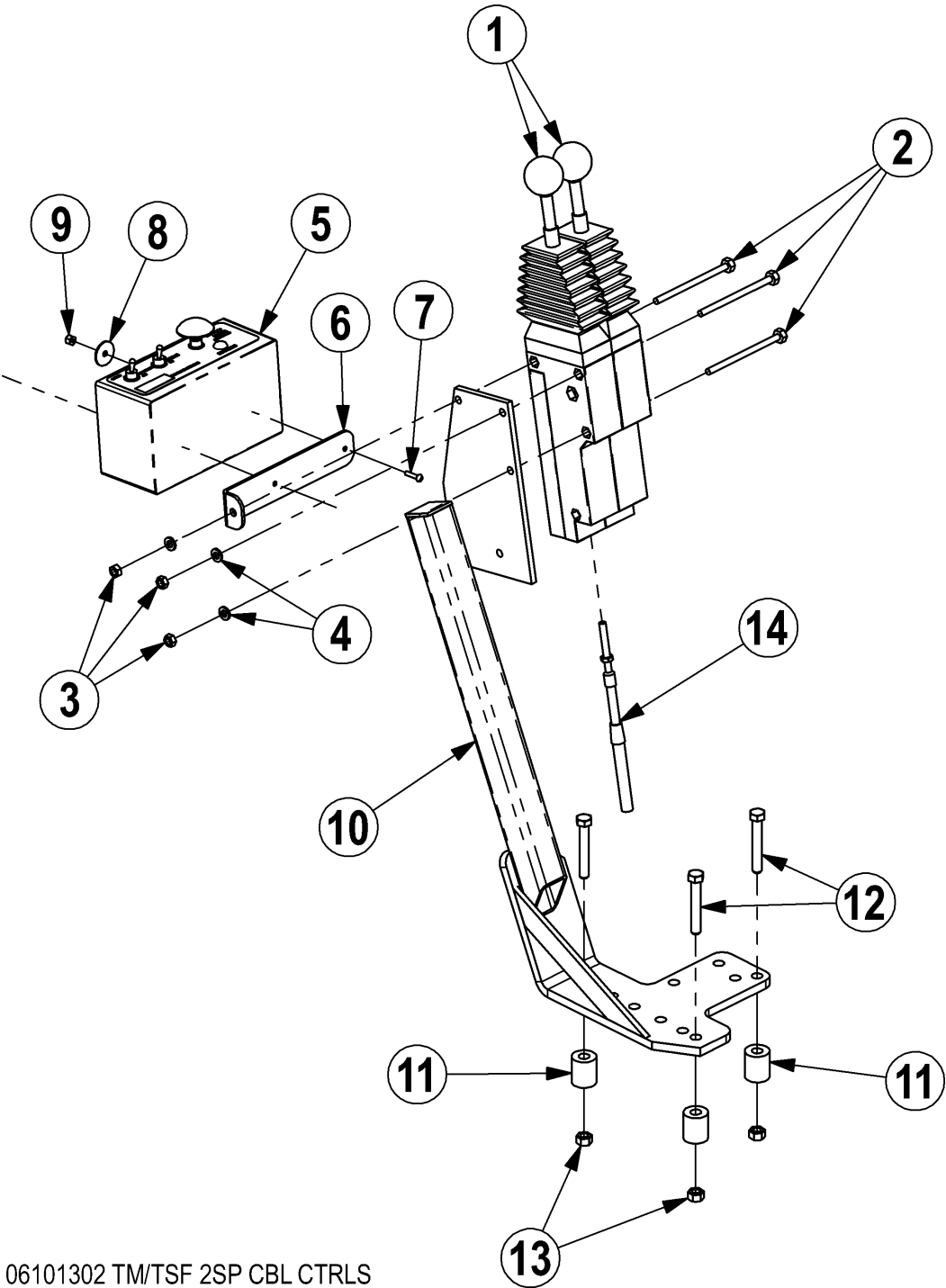

06101302 TM/TSF 2SP CBL CTRLS

2 SPOOL HUSCO CONTROLS - KUBOTA M105X

ITEM	PART NO.	QTY.	DESCRIPTION
1	6T1251	2	CBL CTRL BOX,180 DEG
2	21542	3	CAPSCREW,1/4 X 4 NC
3	21525	3	HEX NUT,1/4 NC
4	21986	3	LOCKWASHER,1/4
5	06510102	1	SWITCHBOX,SIDE,GND
6	34496	1	BRKT,SWITCHBOX,UNI
7	32359	2	SCREW,MACHINE,8-32X3/4
8	34508	2	WASHER,FENDER,#10
9	6T3952	2	HEX NUT,8/32 NYLOCK
10	23865B	1	CBL CTRL MT BRK,9030-FD40-JD60
11	27082B	3	SPACER
12	21636	3	CAPSCREW,3/8 X 2-1/2 NC
13	21627	3	NYLOCK NUT,3/8 NC
14	34623	2	CBL,CNTRL,122

2SP HUSCO LIFT VALVE - COMBO

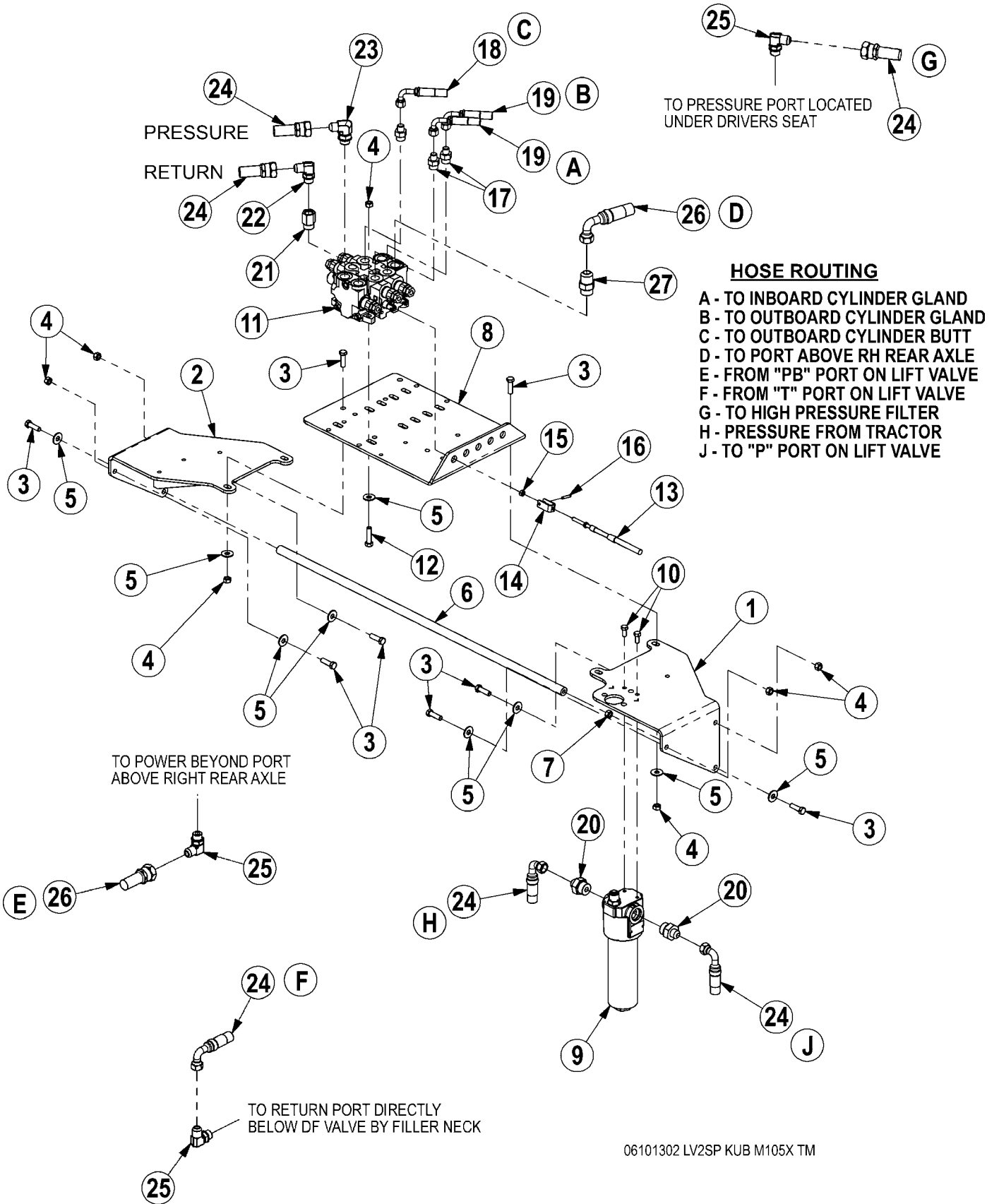

2SP HUSCO LIFT VALVE - COMBO

ITEM	PART NO.	QTY.	DESCRIPTION
1	06340023	1	VALVE MNT,RH,KUB,M105X
2	06340024	1	VALVE MNT,LH,KUB,M105X
3	21631	10	CAPSCREW,3/8 X 1-1/4 NC
4	21627	12	NYLOCK NUT,3/8 NC
5	22016	14	FLATWASHER,3/8
6	06430044	1	BRACE,VLV MNT,KUB
7	21625	1	HEX NUT,3/8 NC
8	34622	1	PLATE,VALVE,REAR MNT
9	06505029	1	FILTER,HP,3/4SAE,11MIC,VIS IND
10	21579	2	CAPSCREW,5/16 X 3/4 NC
11	30801	1	VALVE,2SP,HSC,S/A,D/A,W/PB
12	21632	4	CAPSCREW,3/8 X 1-1/2 NC
13	34623	2	CBL,CNTRL,122
14	6T4411	2	CLEVIS,CBL CTRL,3/16
15	21500	2	HEX NUT,1/4 NF
16	6T3017	2	ROLLPIN,3/16 X 1
17	33271	3	ADAPTER,1/2 MOR X 3/8 MJ
18	34631	1	HOSE,1/4x126(3/8FJXx3/8FJX90)
19	34632	2	HOSE,1/4x115(3/8FJXx3/8FJX90)
20	33591	2	ADAPTER,3/4MORX1/2MJ
21	32678	1	ADAPTER,5/8ORB x 1/2FOR
22	33382	1	ELBOW,1/2MORB X 1/2MJ X 90
23	33383	1	ELBOW,5/8MORB X 1/2MJ X 90
24	33649	3	HOSE,1/2x50(1/2FJXx1/2FJX90)
25	06503066	3	ELBOW,1/2BSPPx1/2MJ,90
26	33486	1	HOSE,1/2X45(1/2FJX90X1/2FJX)
27	06503036	1	ADAPTER,5/8ORBx5/8MJ

2SP HUSCO LIFT VALVE - CABLE

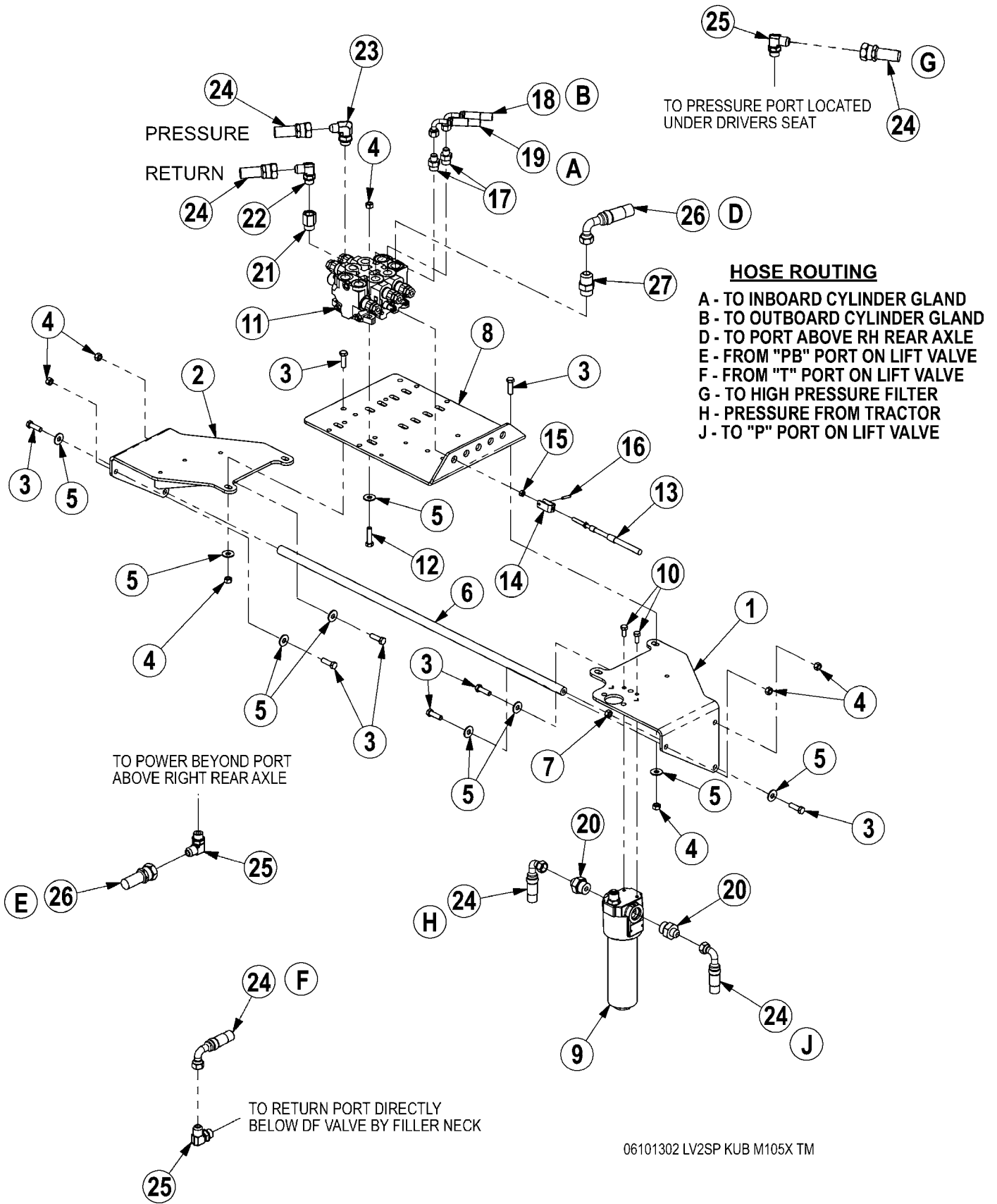

06101302 LV2SP KUB M105X TM

2SP HUSCO LIFT VALVE - CABLE

ITEM	PART NO.	QTY.	DESCRIPTION
1	06340023	1	VALVE MNT,RH,KUB,M105X
2	06340024	1	VALVE MNT,LH,KUB,M105X
3	21631	10	CAPSCREW,3/8 X 1-1/4 NC
4	21627	12	NYLOCK NUT,3/8 NC
5	22016	14	FLATWASHER,3/8
6	06430044	1	BRACE,VLV MNT,KUB
7	21625	1	HEX NUT,3/8 NC
8	34622	1	PLATE,VALVE,REAR MNT
9	06505029	1	FILTER,HP,3/4SAE,11MIC,VIS IND
10	21579	2	CAPSCREW,5/16 X 3/4 NC
11	31752	1	VALVE,2SP,HSC,BLK,2-S/A,PB
12	21632	4	CAPSCREW,3/8 X 1-1/2 NC
13	34623	2	CBL,CNTRL,122
14	6T4411	2	CLEVIS,CBL CTRL,3/16
15	21500	2	HEX NUT,1/4 NF
16	6T3017	2	ROLLPIN,3/16 X 1
17	33271	2	ADAPTER,1/2 MOR X 3/8 MJ
18	34631	1	HOSE,1/4x126(3/8FJXx3/8FJX90)
19	34632	1	HOSE,1/4x115(3/8FJXx3/8FJX90)
20	33591	2	ADAPTER,3/4MORX1/2MJ
21	32678	1	ADAPTER,5/8ORB x 1/2FOR
22	33382	1	ELBOW,1/2MORB X 1/2MJ X 90
23	33383	1	ELBOW,5/8MORB X 1/2MJ X 90
24	33649	3	HOSE,1/2x50(1/2FJXx1/2FJX90)
25	06503066	3	ELBOW,1/2BSPPx1/2MJ,90
26	33486	1	HOSE,1/2X45(1/2FJX90X1/2FJX)
27	06503036	1	ADAPTER,5/8ORBx5/8MJ

2SP HUSCO VALVE - POWER BEYOND (30801)

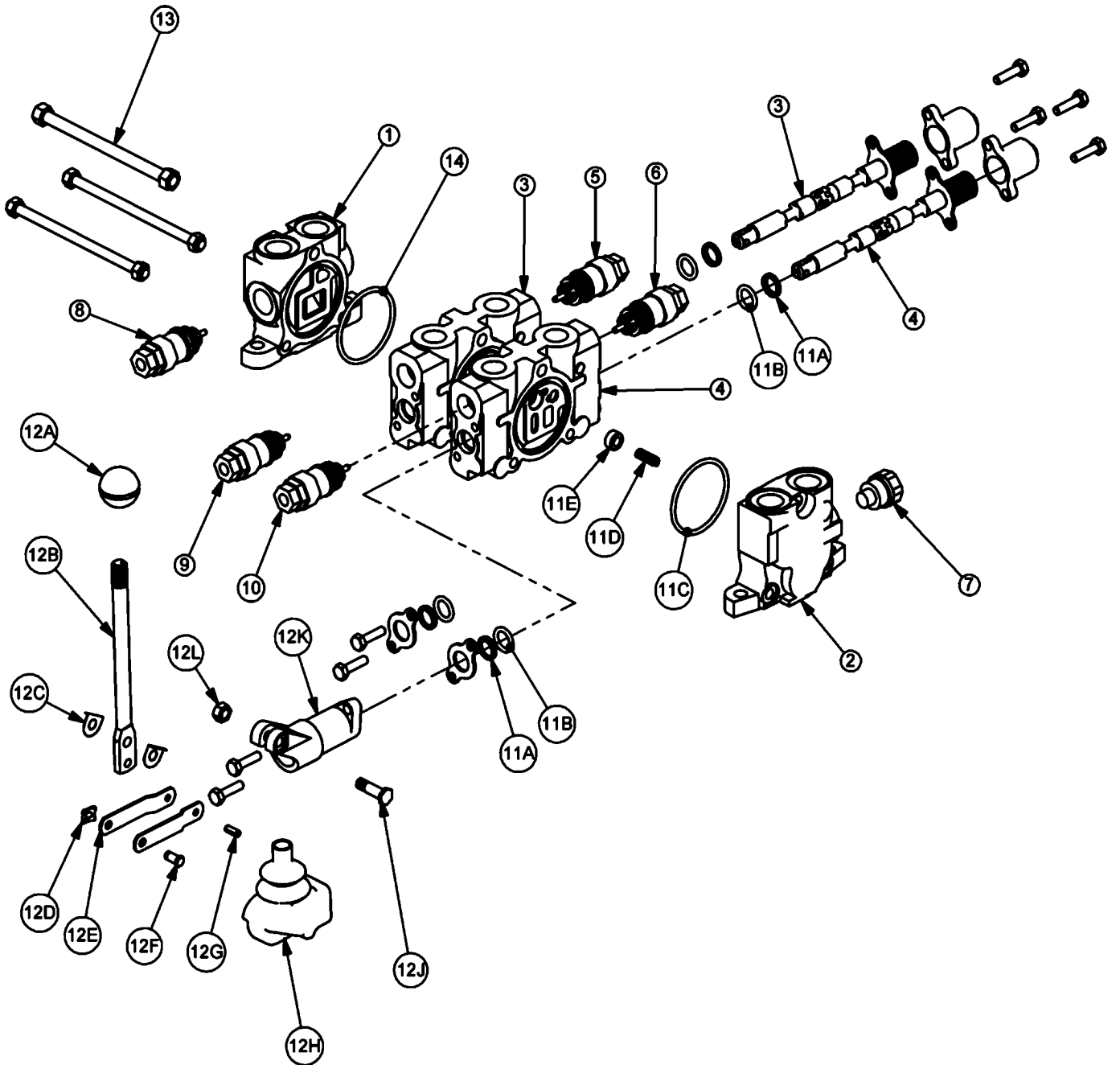

2SP HUSCO VALVE - POWER BEYOND (30801)

ITEM	PART NO.	QTY	DESCRIPTION
1	TB1017S	1	INLET END COVER
2	TB1702	1	END COVER, POWER BEYOND
3	TB1017P	1	VALVE SECTION (SINGLE ACTING, SPRING DETENT)
4	06502091	1	VALVE SECTION (DOUBLE ACTING, CENTER SPRING) (NO AUX VALVE PORTS)
5	N/A	-	N/A
6	N/A	-	N/A
7	TB1017M	1	SHUT-OFF PLUG
8	TB1017E	1	RELIEF VALVE, 2250 PSI
9	TB1017M	1	SHUT-OFF PLUG
10	TB1017M	1	SHUT-OFF PLUG
11	TB1017A	2	VALVE SEAL KIT (FOR ONE SECTION)
11A		2	WIPER
11B		2	O-RING SMALL
11C		1	O-RING LARGE
11D		1	SPRING
11E		1	PUCKET
12	TB1017L	2	LEVER KIT (FOR ONE SECTION)
12A		1	LEVER KNOB
12B		1	LEVER
12C		2	LEVER WASHER
12D		1	LEVER CLIP
12E		2	LINKAGE
12F		1	LEVER PIN
12G		1	ROLL PIN
12H		1	LEVER BOOT
12J		1	LEVER BOLT
12K		1	LEVER DUST COVER
12L		1	LEVER NUT
13	TB1017X	1	TIE ROD KIT
14	24214	1	O-RING, LARGE

2SP HUSCO VALVE - POWER BEYOND (31752)

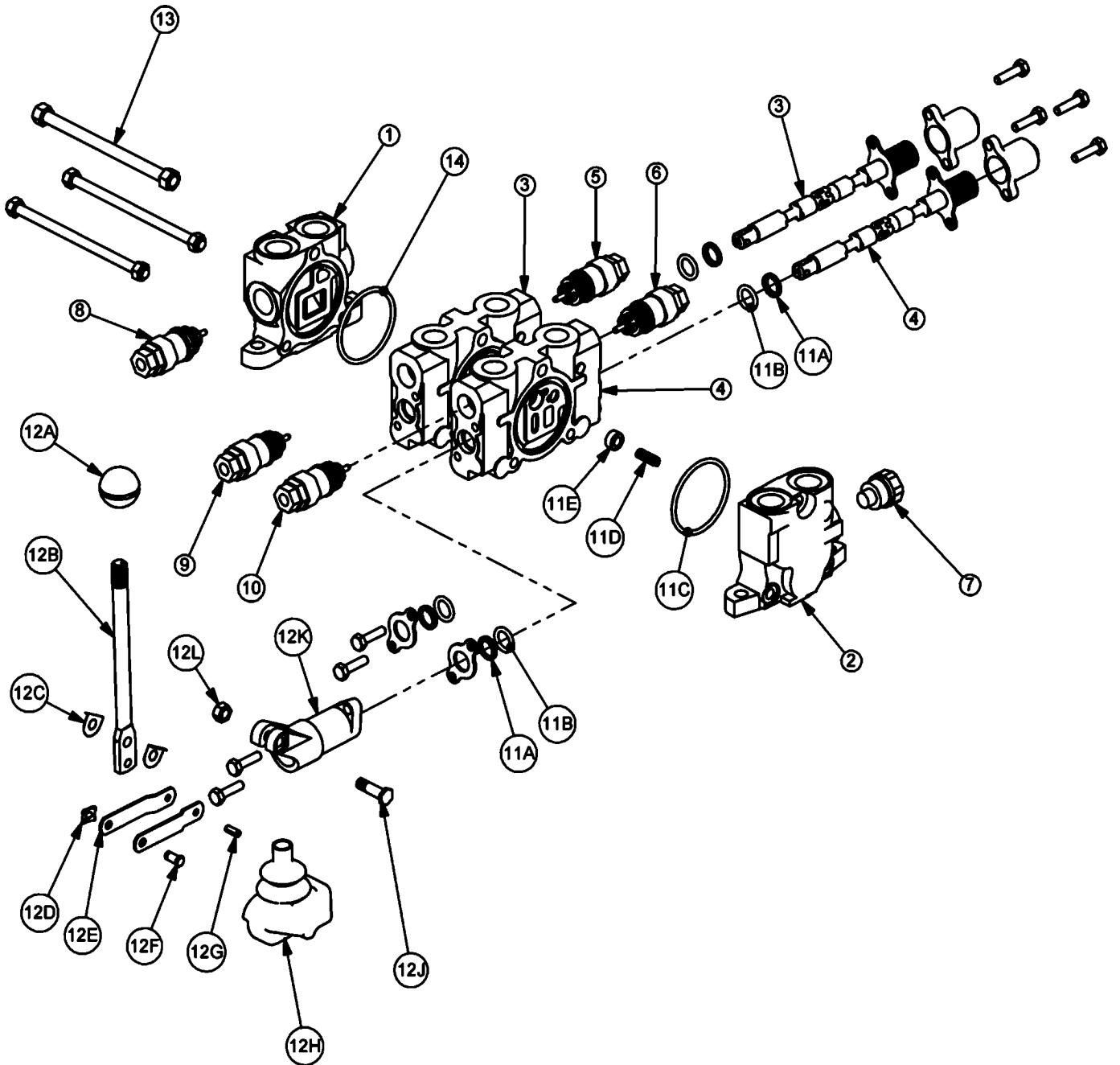

2SP HUSCO VALVE - POWER BEYOND (31752)

ITEM	PART NO.	QTY	DESCRIPTION
1	TB1017S	1	INLET END COVER
2	TB1702	1	END COVER, POWER BEYOND
3	TB1017P	1	VALVE SECTION (SINGLE ACTING, SPRING DETENT)
4	TB1017P	1	VALVE SECTION (SINGLE ACTING, SPRING DETENT)
5	N/A	-	N/A
6	N/A	-	N/A
7	TB1017M	1	SHUT-OFF PLUG
8	TB1017E	1	RELIEF VALVE, 2250 PSI
9	TB1017M	1	SHUT-OFF PLUG
10	TB1017M	1	SHUT-OFF PLUG
11	TB1017A	2	VALVE SEAL KIT (FOR ONE SECTION)
11A		2	WIPER
11B		2	O-RING SMALL
11C		1	O-RING LARGE
11D		1	SPRING
11E		1	PUCKET
12	TB1017L	2	LEVER KIT (FOR ONE SECTION)
12A		1	LEVER KNOB
12B		1	LEVER
12C		2	LEVER WASHER
12D		1	LEVER CLIP
12E		2	LINKAGE
12F		1	LEVER PIN
12G		1	ROLL PIN
12H		1	LEVER BOOT
12J		1	LEVER BOLT
12K		1	LEVER DUST COVER
12L		1	LEVER NUT
13	TB1017X	1	TIE ROD KIT
14	24214	1	O-RING, LARGE

SAFETY SCREEN - KUBOTA M105X

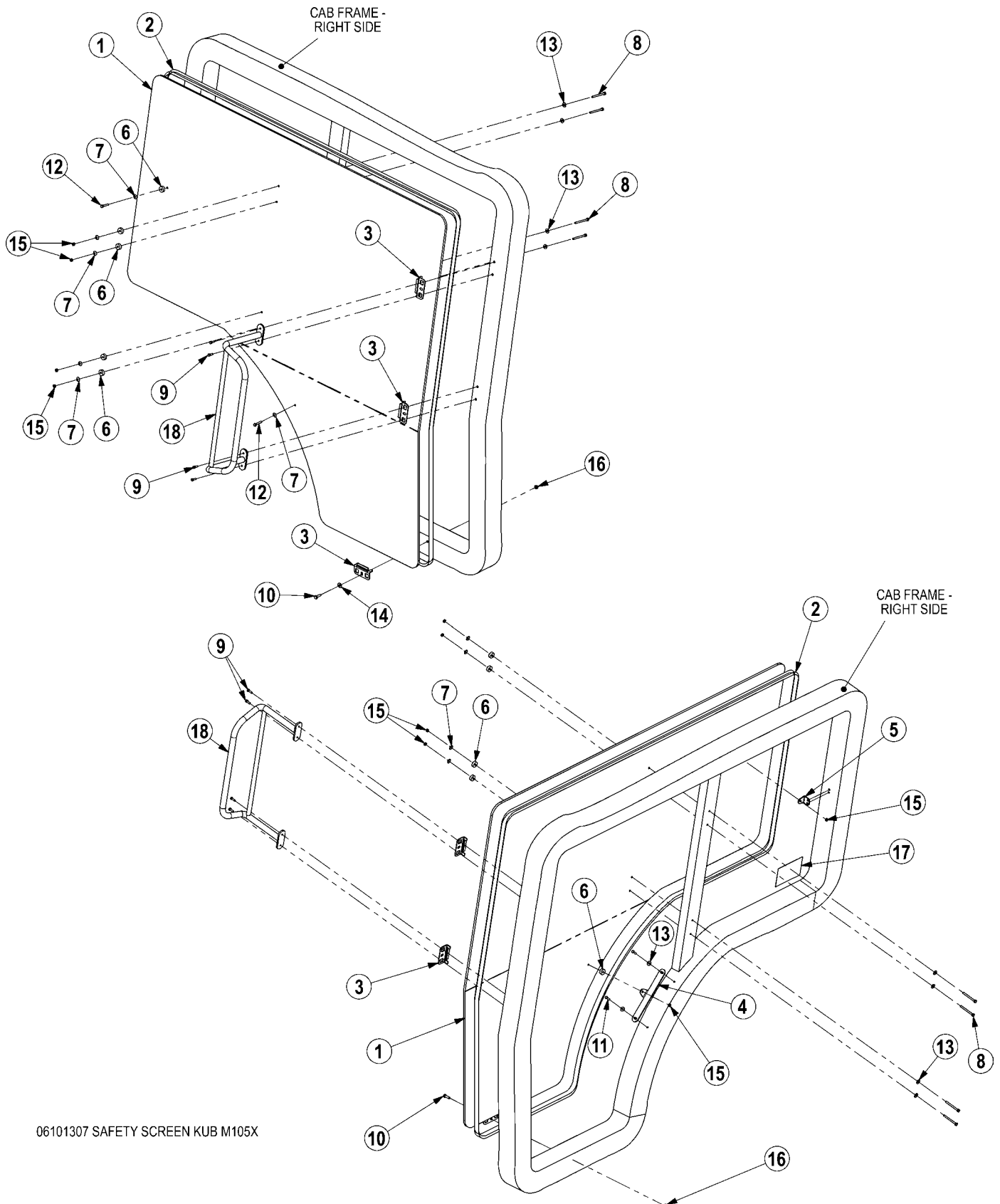

06101307 SAFETY SCREEN KUB M105X

SAFETY SCREEN - KUBOTA M105X

ITEM	PART NO.	QTY.	DESCRIPTION
1	06490023	1	POLYCARB,FRMD,KUB,M105X,RH
2	31965	20'	TRIM SEAL,3/8 CLIP X 3/4 OD
3	06520040	3	BRKT,JD,POLY,RETAIN
4	06410391	1	MNT,POLY,KUB
5	06410392	1	MNT,SM,POLY,KUB
6	06537000	6	WASHER,NEOPRENE,.25x1x.38
7	06537001	6	WASHER,RUBBERIZED,.25,CONICAL
8	21538	4	CAPSCREW,1/4 X 3 NC
9	27506	4	CAPSCREW,6MMX20MM(1.0 PITCH)
10	21580	1	CAPSCREW,5/16 X 1 NC
11	06530511	2	CAPSCREW,6MMX25MM(1.0 PITCH)
12	21532	2	CAPSCREW,1/4 X 1-1/2 NC
13	22014	6	FLATWASHER,1/4
14	22015	1	FLATWASHER,5/16
15	21527	6	NYLOCK NUT,1/4 NC
16	21577	1	NYLOCK NUT,5/16 NC
17	22645	1	DECAL,POLYCARBONATE WINDOW INS
18	*	1	EXISTING - RIGHT HAND RAIL

OPTIONAL PUMP GUARD KIT

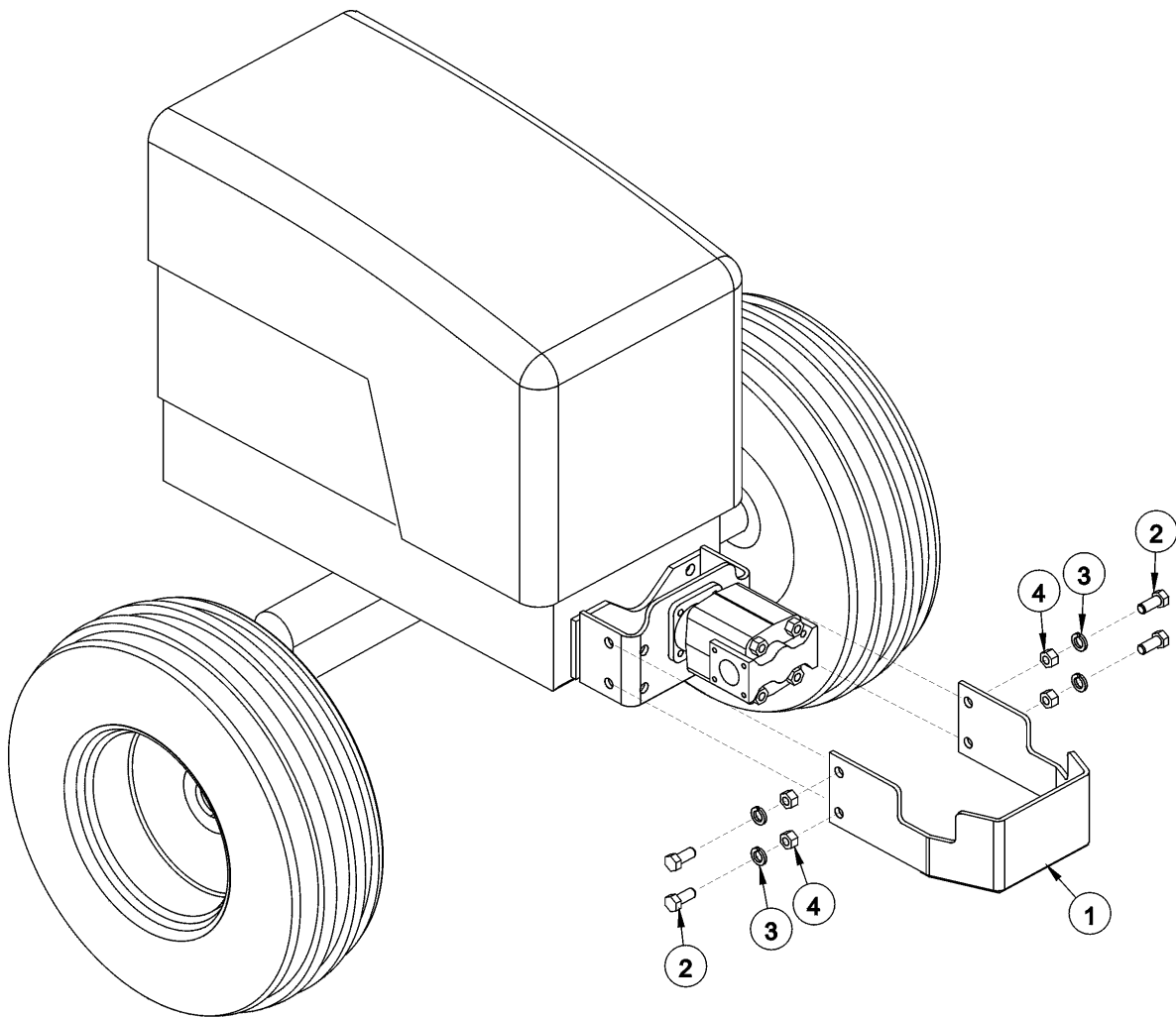

06200342

ITEM	PARTNO.	QTY.	DESCRIPTION
1	32430	1	UNIVERSAL PUMP GUARD
2	21831	4	CAPSCREW - 3/4 X 1 3/4
3	21993	4	LOCKWASHER - 3/4
4	21825	4	HEX NUT - 3/4

OPTIONAL PUMP AND GRILL GUARD KIT

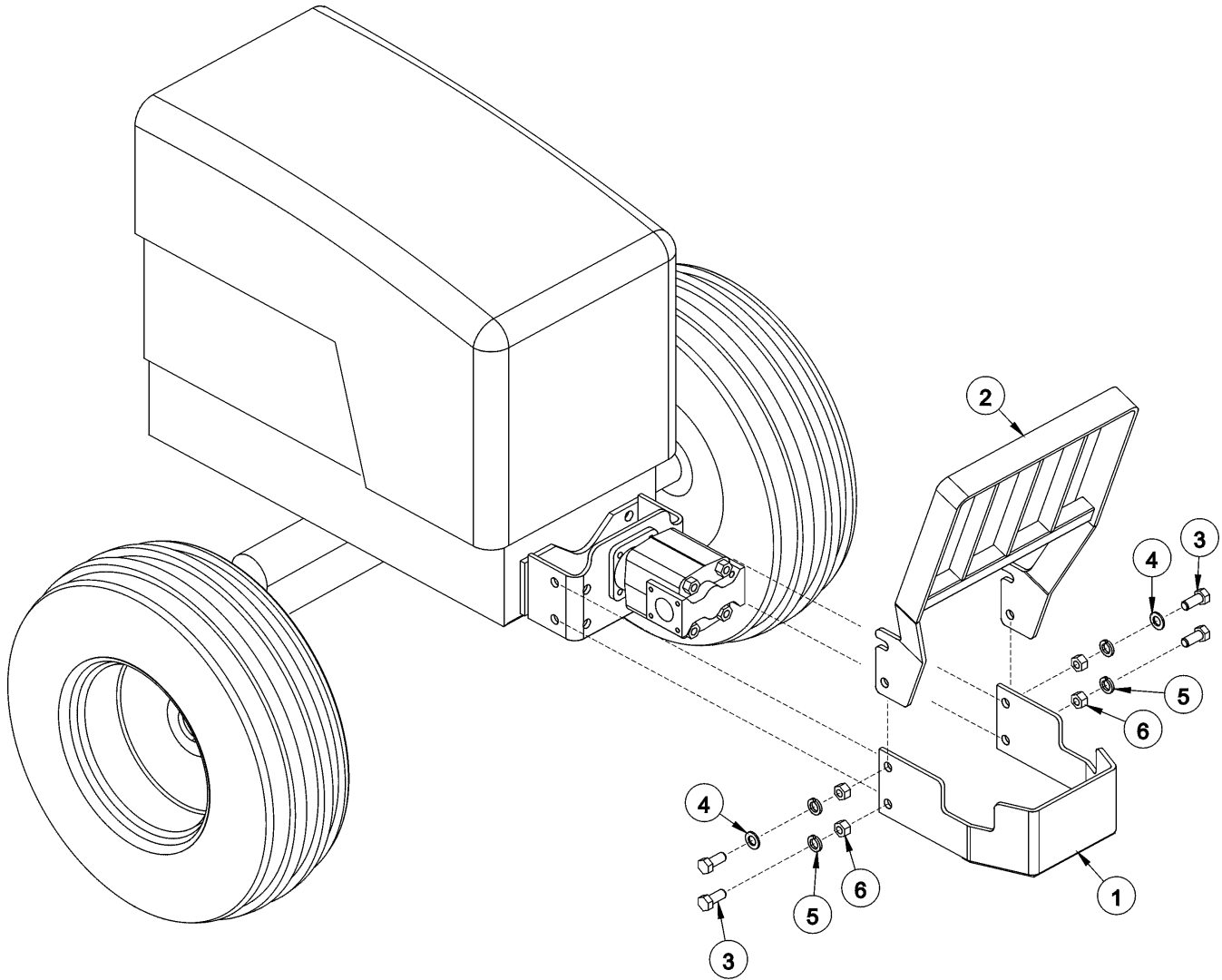

06200349

ITEM	PART NO.	QTY.	DESCRIPTION
1	32430	1	UNIVERSAL PUMP GUARD
2	32737	1	UNIVERSAL GRILL GUARD
3	21833	4	CAPSCREW - 3/4 X 2 1/4
4	22021	2	FLATWASHER - 3/4
5	21993	4	LOCKWASHER - 3/4
6	21825	4	HEX NUT - 3/4

FUEL TANK - KUBOTA M105X

06101300 KUBOTA M105X FUEL TANK

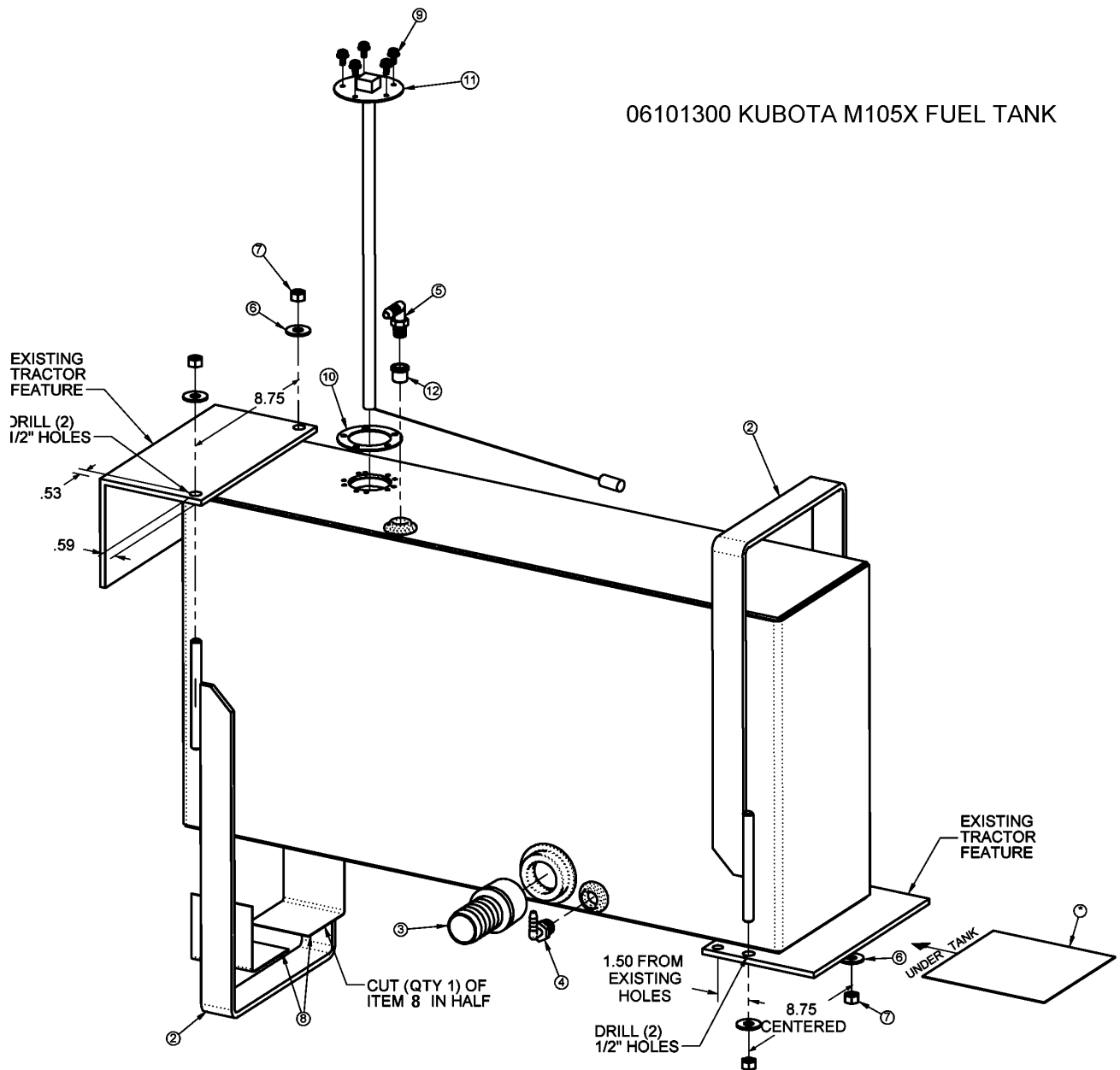

ITEM	PART NO.	QTY.	DESCRIPTION
1	06370048	1	FUEL TANK,RH,KUB,M105X
2	06370049	2	TANK STRAP,KUB,M105X
3	06503061	1	ADAPTER,1 1/4NPTx1 1/4BARB
4	06503063	1	ELBOW,3/8NPTx3/8BARB
5	06503092	1	ELBOW,1/4NPTx1/4BARB
6	22016	4	FLATWASHER,3/8
7	21627	4	NYLOCK NUT,3/8 NC
8	6T3200	2	SPLIT HOSE
9	*	5	EXISTING HARDWARE
10	*	1	EXISTING HARDWARE
11	*	1	EXISTING HARDWARE
12	06503091	1	ADAPTER

SWITCH BOX SCHEMATIC

06510102 SCHEMATIC COMMON GROUND SWITCH BOX SIDE MOWER

NOTE:
ADD METRIPAK 150
FEMALE PLUG (MALE PINS)
W/JUMPER WIRES

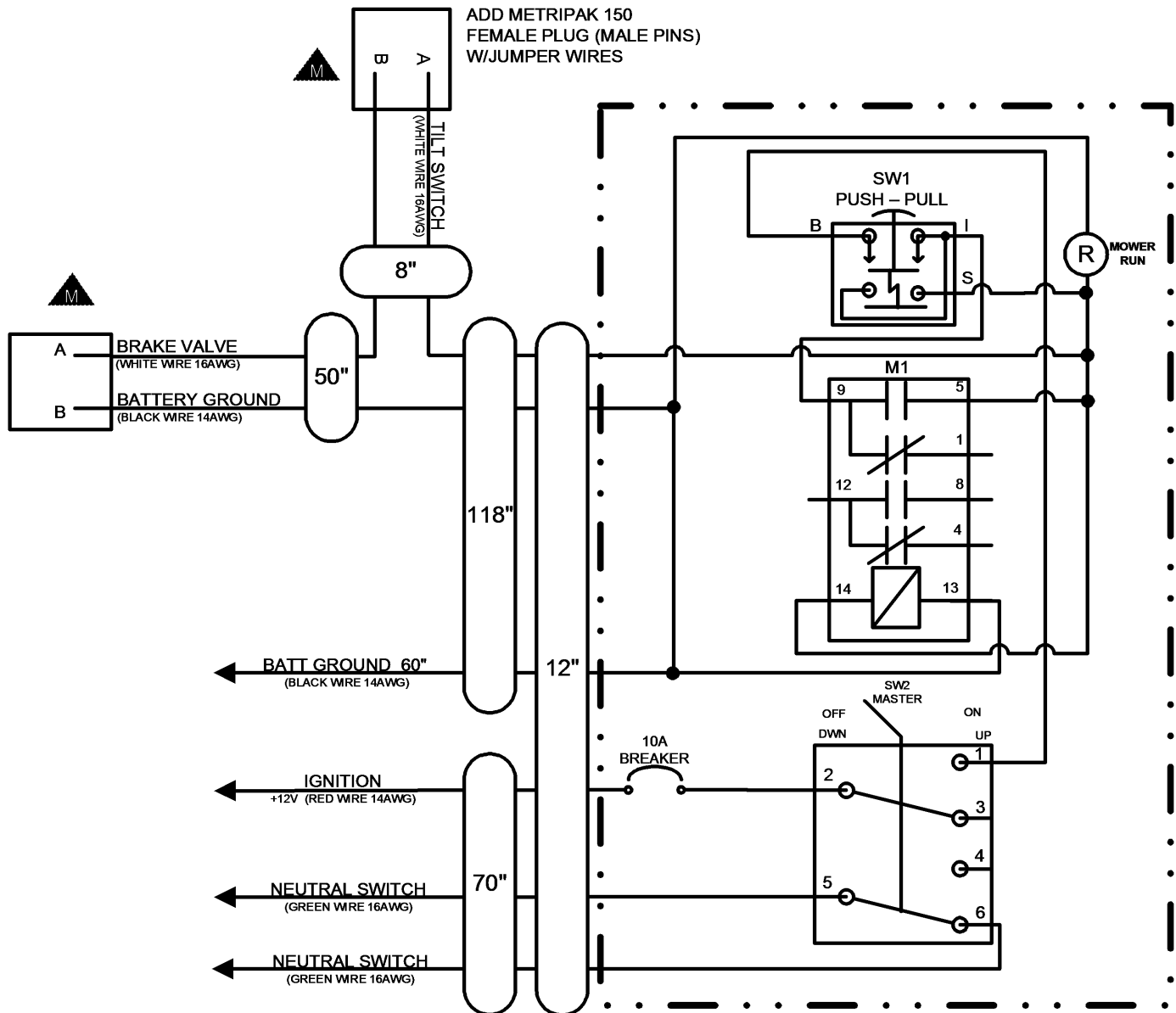

SEE DRAWING # 06515000 FOR A FULL DESCRIPTION OF ALL CONNECTORS

SOLENOID BRAKE VALVE ASSEMBLY

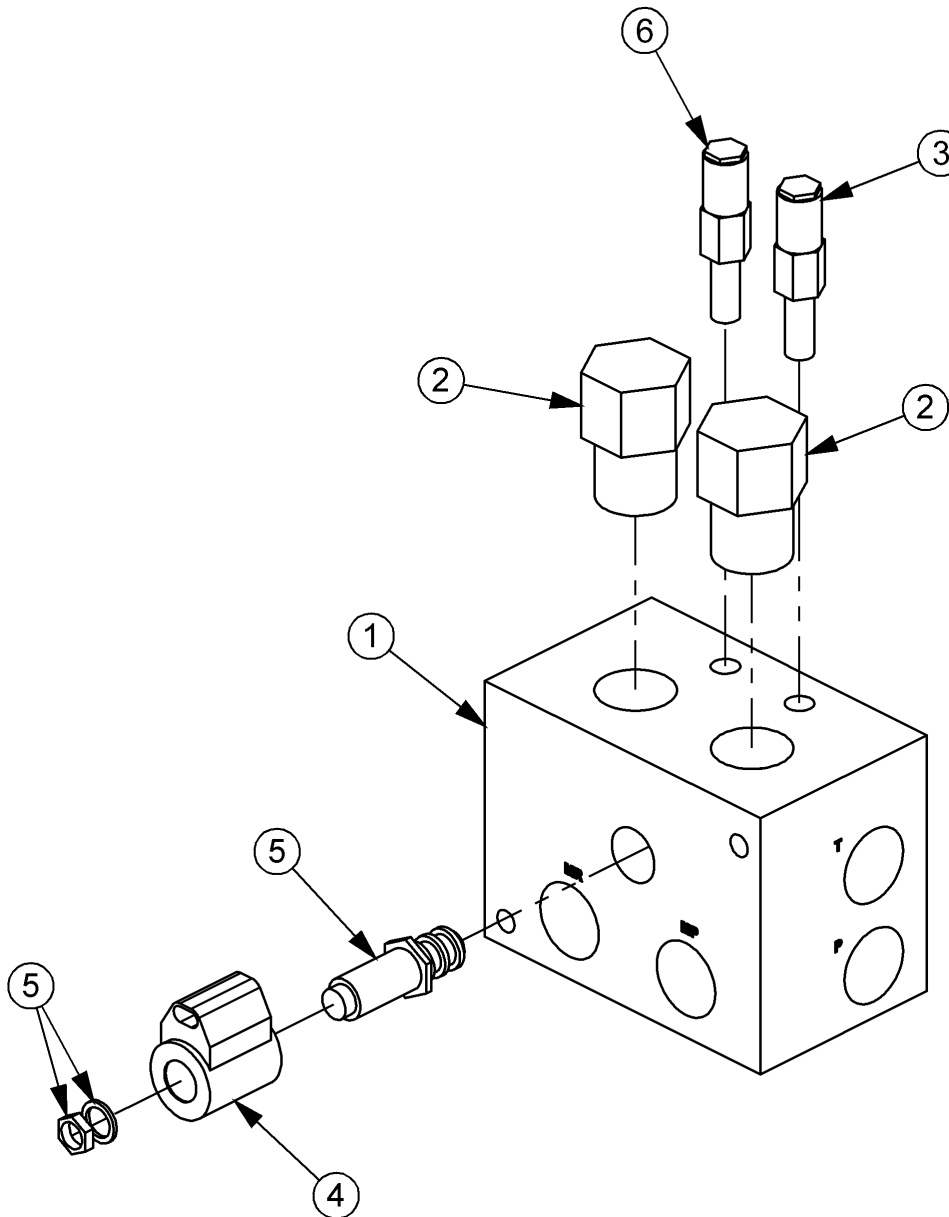

ITEM	PARTNO.	QTY.	DESCRIPTION
1	34092	1	BRAKE VALVE, BLANK
2	34095	1	RELIEF VALVE, 3000 PSI
3	34094	2	LOGIC ELEMENT
4	06510095	1	METRI PAK COIL
5	34093	1	CARTRIDGE, 2 POSITION, 3 WAY (WITH NUT & WASHER)

SOLENOID BRAKE VALVE HYDRAULIC SCHEMATIC

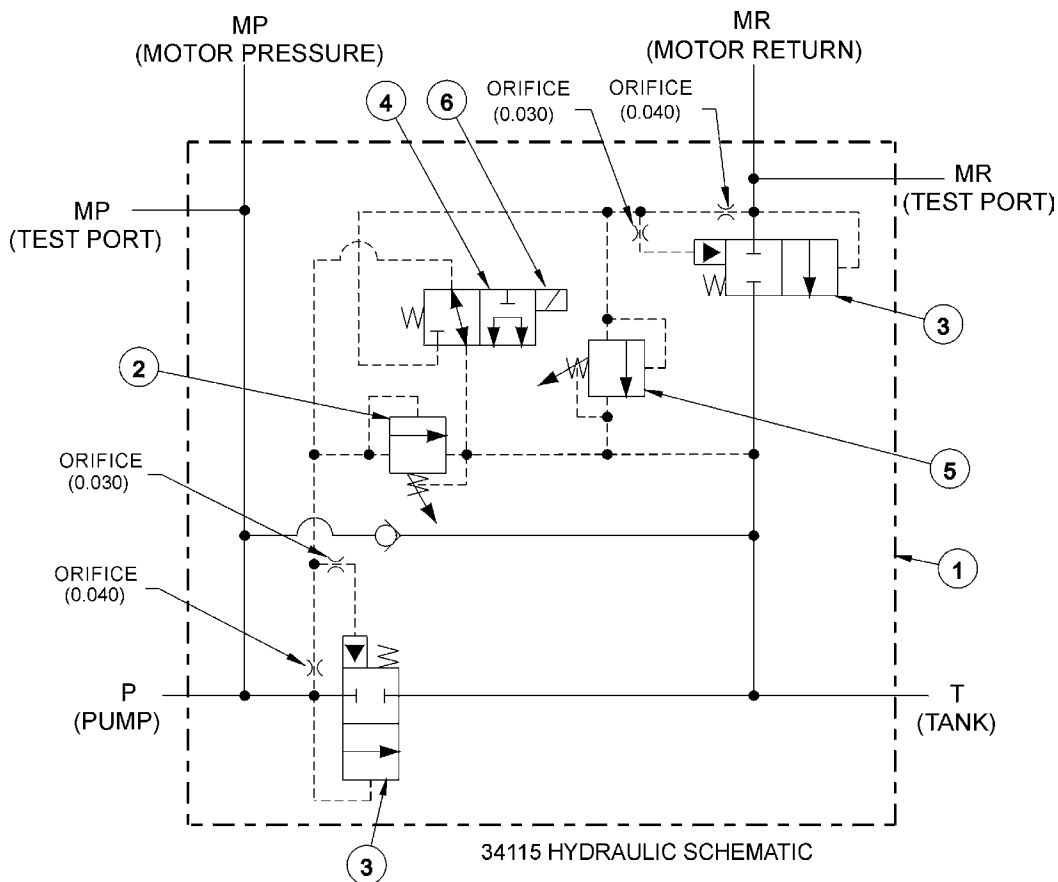

BRAKE VALVE TROUBLESHOOTING

FAILURE MODE:

- MOWER WILL NOT START - system pressure is low (engine not lugging).
- MOWER WILL NOT START - system pressure is high (engine lugging). "MR" port will be high pressure.
- MOWER WILL NOT ROTATE AT FULL SPEED - limited power.
- MOWER BLADE WILL NOT STOP - blade will not stop in proper time.

CHECK STEPS

- 1 thru 6
- 7
- 3 thru 5
- 7 thru 9

CORRECTIVE STEPS:

1. Check for voltage at solenoid (item 6), voltage must be between 10.2 volts and 13.8 volts.
2. Remove, inspect solenoid and cartridge (items 4, 6) for wear or contamination.
3. Remove, inspect logic elements near "P" port (item 3) for wear or contamination.
4. Remove, inspect 3000 psi relief valve (item 2) for wear or contamination.
5. Remove and inspect orifices near "P" port for contamination.
6. Remove "P" port hose and fitting, visually inspect for contamination, check ball for movement.
7. Remove and inspect orifices near "MR" port for contamination.
8. Remove, inspect 2600 psi relief valve (item 5) for wear of contamination.
9. Remove, inspect logic element near "MR" port (item 3) for wear or contamination.

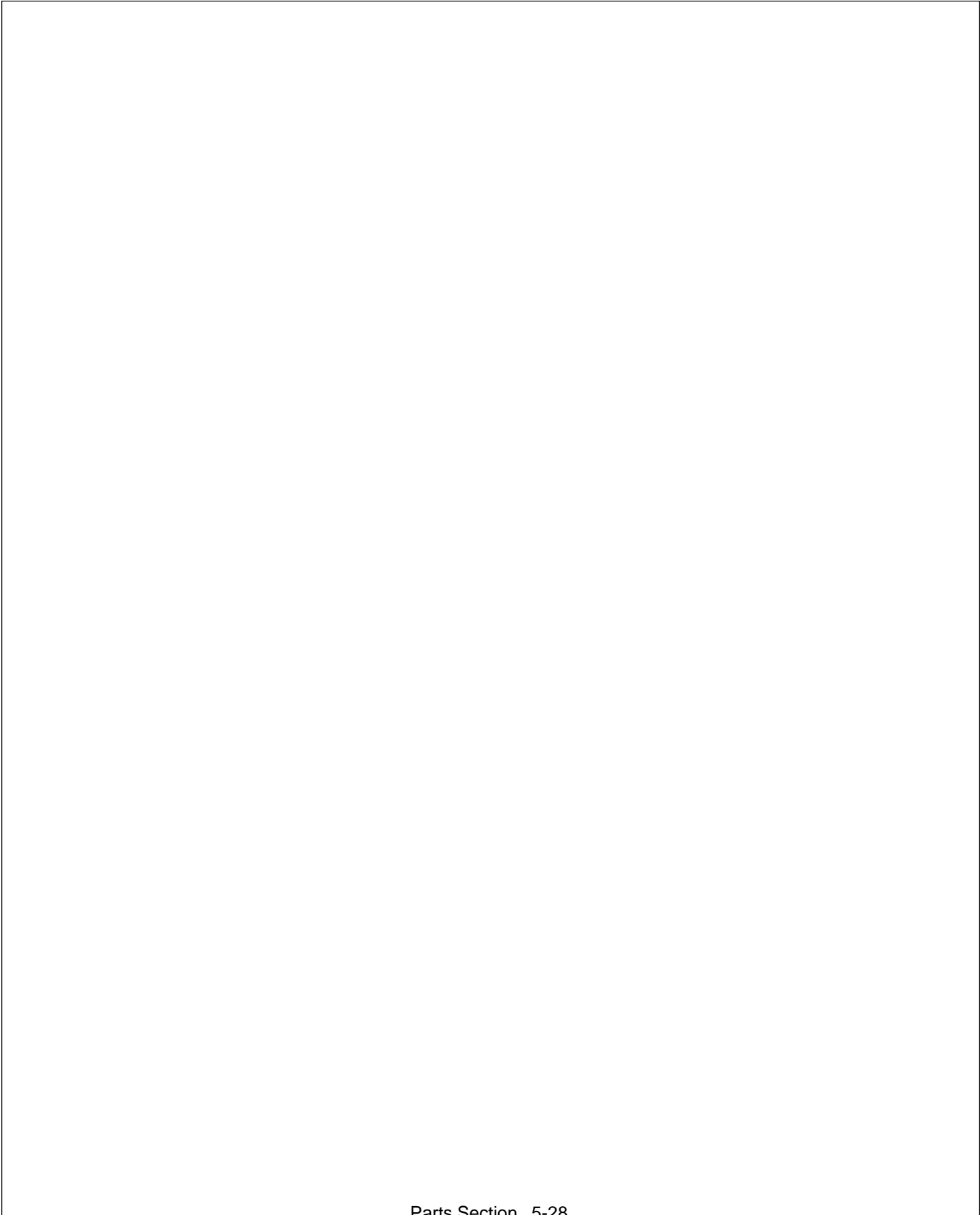
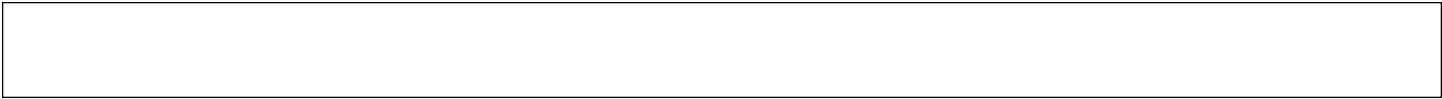

SIDE ROTARYCOMMON SECTION

**COMMON
PARTS
SECTION**

TABLE OF CONTENTS

SECTION	ASSEMBLY	PAGE
CABLE LIFT ASSEMBLY		6-4
COMBO DRAFT BEAM		6-6
60" SIDE CABLE ROTARY MOWER ASSEMBLY		6-8
72" SIDE CABLE ROTARY MOWER ASSEMBLY		6-10
60" SIDE COMBO RTRY MOWER ASSEMBLY		6-12
60" SIDE ROTARY MOWER		6-14
60" SPINDLE AND SPACER		6-16
72" SIDE COMBO ROTARY MOWER ASSY		6-18
TM72" MOTOR ASSEMBLY		6-20
CHAIN GUARDS		6-22
SIDE ROTARY CASTER WHEEL ASSEMBLY		6-24
RESERVOIR TANK FILTER ASSEMBLY		6-26
MOWER SPINDLE ASSEMBLIES		6-28
HYDRAULIC LIFT CYLINDER		6-32
ROTARY KNIVES AND DISKS		6-34
CASTER WHEEL ASSEMBLY		6-35
ROTARY MOTORS		6-36
FRONT HYDRAULIC PUMP		6-38
TSR MOTOR		6-38
COOLER ASSEMBLY		6-40
2 SPOOL HUSCO VALVES		6-42
SOLENOID VALVE ASSEMBLY		6-54
SOLENOID BRAKE VALVE ASSEMBLY		6-55
BRAKE VALVE ASSEMBLY W/METRI PAK		6-56
SOLENOID BRAKE VALVE SCHEMATIC		6-57
TRAVEL LOCK LIFT BEAM		6-58
SIDE MOWER TRAVEL LOCK (COMBO)		6-59
SWITCHBOX SCHEMATIC		6-60

PARTS ORDERING GUIDE

The following instructions are offered to help eliminate needless delay and error in processing purchase orders for the equipment in this manual.

1. The Parts Section is prepared in logical sequence and grouping of parts that belong to the basic machine featured in this manual. Part Numbers and Descriptions are given to help locate the parts and quantities required.

2. The Purchase Order must indicate the **Name and Address** of the person or organization ordering the parts, **who should be charged**, and if possible, the **serial number of the machine** for which the parts are being ordered.

3. The purchase order must clearly list the **quantity of each part**, the complete and correct **part number**, and the basic **name of the part**.

4. The manufacturer reserves the right to substitute parts where applicable.

5. Some parts may be unlisted items which are special production items not normally stocked and are subject to special handling. Request a quotation for such parts before sending a purchase order.

6. The manufacturer reserves the right to change prices without prior notice.

NOTE: When ordering replacement decals, refer to the part numbers and descriptions listed in the safety section in the front of this manual.



1000

For maximum safety and to guarantee optimum product reliability, always use genuine **Tiger** replacement parts. The use of inferior replacement parts may cause premature or catastrophic failure which could result in serious injury or death.

Direct any questions regarding parts to:

Tiger Corporation
3301 N. Louise Ave.
Sioux Falls, SD 57107
1-800-843-6849
1-605-336-7900

CABLE LIFT ASSEMBLY

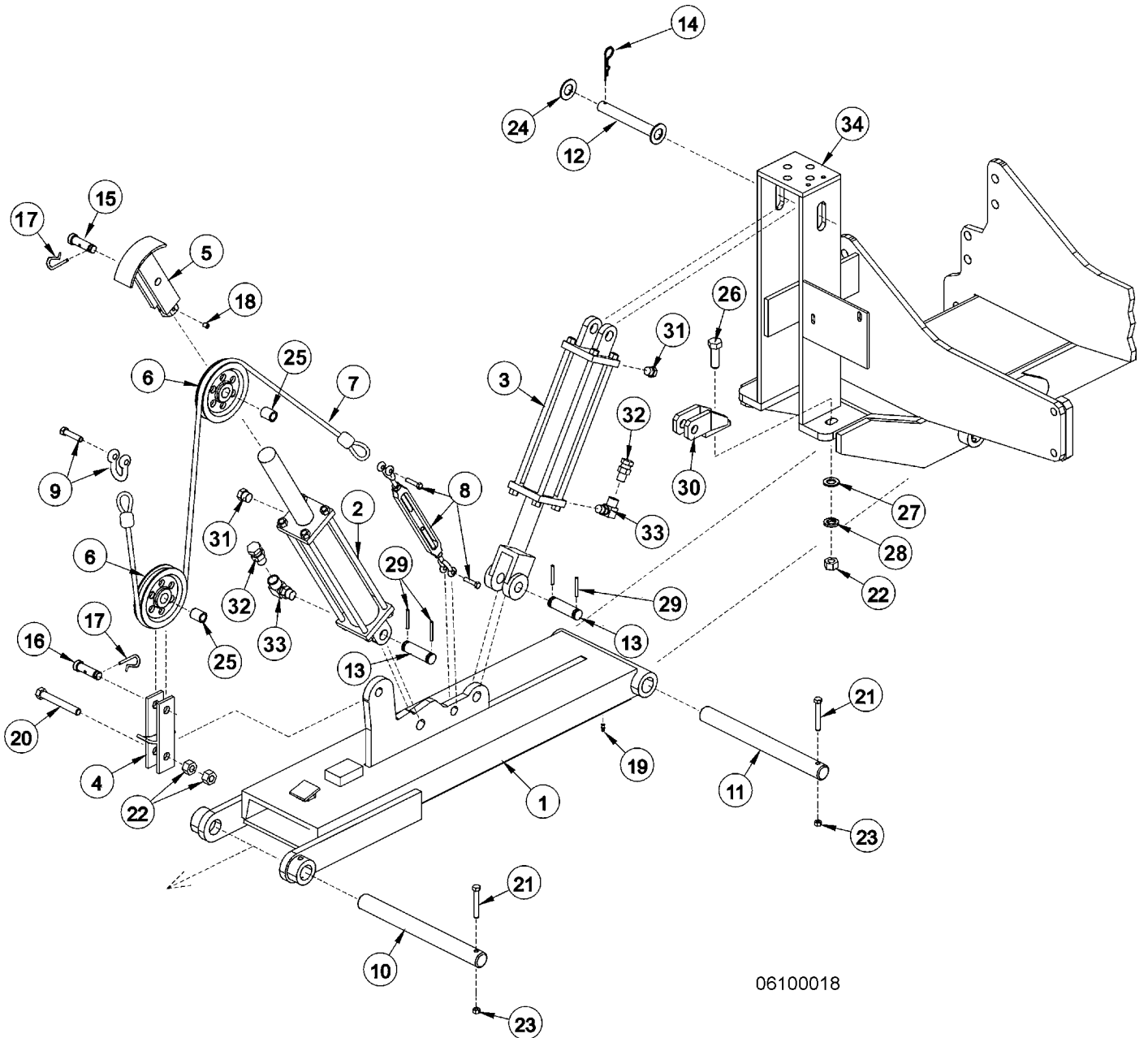

06100018

CABLE LIFT ASSEMBLY

ITEM	PART NO.	QTY.	DESCRIPTION
1	6T0103A	1	DRAFT BEAM (STD 25 LB, 45 3/8")
	6T0103E	OPT.	DRAFT BEAM (EXTENDED 6" 4WD)
	6T0103L	OPT.	DRAFT BEAM (EXTENDED 15")
	6T0105	OPT.	DRAFT BEAM (STD WITH TRAVEL LOCK)
	6T0108	OPT.	DRAFT BEAM (30 LB CHANNEL, 45 3/8")
2	6T0150	1	CYLINDER 3" X 18"
3	6T0151R	1	CYLINDER 3" X 10"
4	6T0100	1	LOWER SHEAVE BRACKET
5	6T0101	1	UPPER SHEAVE BRACKET
6	33768	2	SHEAVE
7	6T0110	1	LIFT CABLE (STD 1/2" X 87 1/2")
	6T0110E	OPT.	LIFT CABLE (EXTENDED 6" 4WD)
	6T0110L	OPT.	LIFT CABLE (EXTENDED 15")
8	6T0115	1	TURN BUCKLE
9	6T0112	1	SHACKLE WITH PIN
10	6T2999	1	OUTER DRAFT BEAM PIN 1 1/2" X 14 1/2"
11	6T3001	1	INNER DRAFT BEAM PIN 1 1/2" X 15 3/4"
12	6T3005	1	PIN ,1" W/ CAP
13	TB1033	2	CLEVIS PIN 1" X 4"
14	6T3004	1	R - CLIP 3/16"
15	6T3010	1	UPPER SHEAVE PIN WITH ZERK 3/4" X 3"
16	6T3009	1	LOWER SHEAVE PIN WITH ZERK 3/4" X 2 1/2"
17	6T3020	2	R - CLIP 5/32"
18	6T2272	1	SET SCREW 3/8" X 1/2"
19	6T3211	1	GREASE ZERK 1/8" STRAIGHT
20	21836	1	CAPSCREW 3/4" X 3"
21	21688	2	CAPSCREW 7/16" X 3 1/4"
22	21825	2	HEX NUT 3/4"
23	21677	2	NYLOCK NUT 7/16"
24	22023	1	FLAT WASHER 1"
25	6T0104N	2	SHEAVE PIN BUSHING 1" OD X 3/4" ID
26	21833	1	CAPSCREW 3/4" X 2 1/4"
27	22021	1	FLAT WASHER 3/4"
28	21993	1	LOCK WASHER 3/4"
29	06537021	4	ROLL PIN
30	6T0106	1	TRAVEL LOCK BRACKET
31	6T4258	1	BREATHER 1/2"
32	34396	2	RESTRICTOR
33	34244	2	ELBOW FITTING 1/2"
34	*	REF.	MAIN FRAME REFER TO TRACTOR PARTS SECTION

COMBO DRAFT BEAM

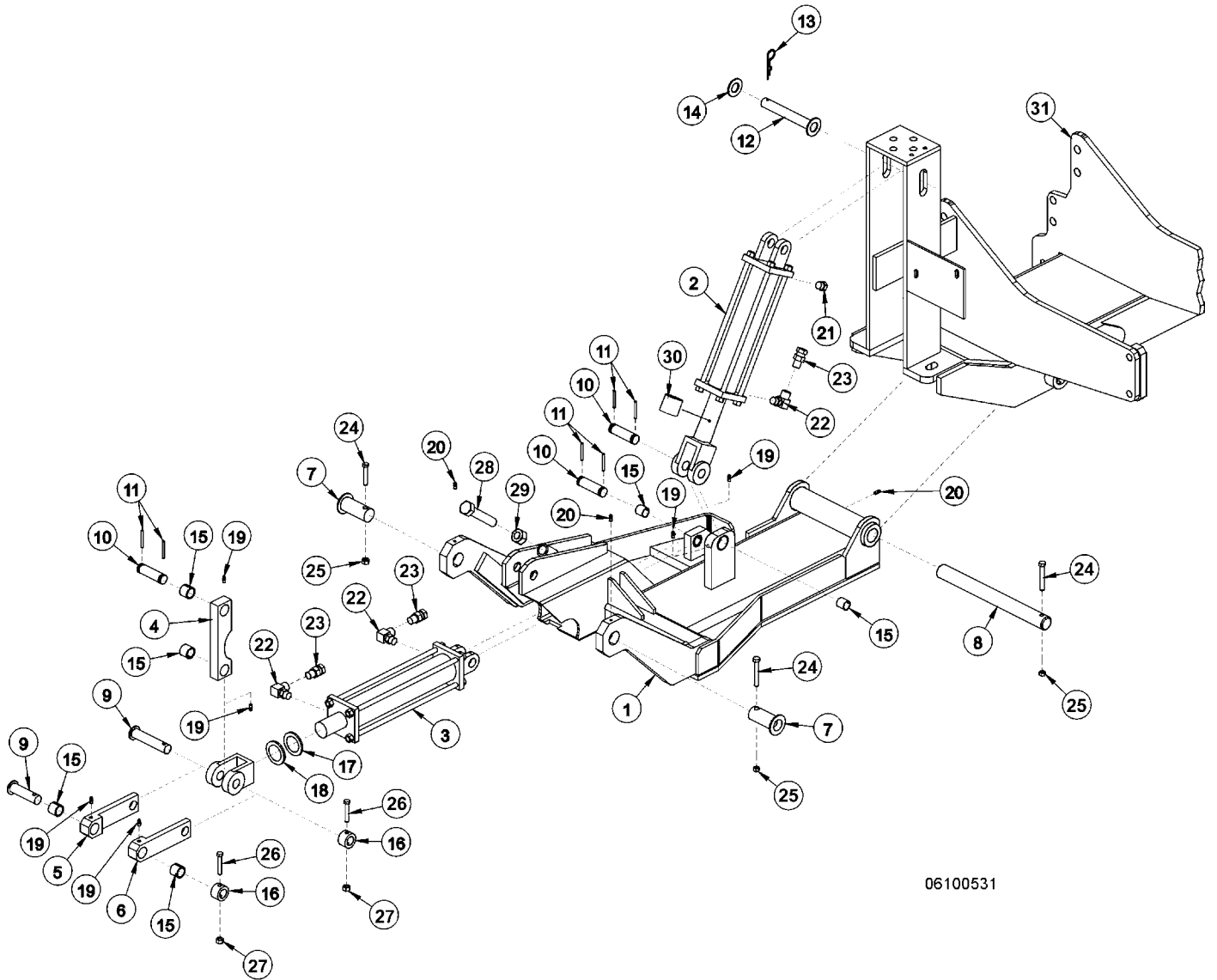

06100531

COMBO DRAFT BEAM

ITEM	PART NO.	QTY.	DESCRIPTION
1	06350001 31063	1 OPT.	COMBO DRAFT BEAM - STD DTY ROTARY COMBO DRAFT BEAM - HVY DTY ROTARY
2	6T0151R	1	HYD. CYLINDER 3" X 10"
3	32215 25343	1 REF	HYD. CYLINDER 3" X 12" - STD DTY HYD. CYLINDER 3" X 12" - HVY DTY
4	TF4500A	1	PIVOT ARM
5	TF4507B	1	RIGHT LINKAGE ARM
6	TF4506B	1	LEFT LINKAGE ARM
7	30126B TF4514A	2 REF	PIN, HEAD PIVOT - STD DTY PIN, HEAD PIVOT - HVY DTY
8	6T3001	1	PIN, BEAM PIVOT
9	TF4519	2	PIN, LINKAGE
10	TB1033	3	PIN, CLEVIS
11	06537021	6	ROLLPIN
12	6T3005	1	PIN, 1" W/ CAP
13	6T3004	1	R-CLIP HAIRPIN
14	6T2614	1	FLATWASHER 1"
15	TB3010	8	BUSHING 1"
16	22847	2	BOSS, LINKAGE PIN
17	22076	1	SPACER, HYD. CYLINDER 1/4"
18	22077	1	SPACER, HYD. CYLINDER 5/16"
19	6T3207	6	GREASE ZERK 1/4"
20	6T3211	3	GREASE ZERK 1/8"
21	6T4258	1	BREATHER 1/2"
22	34244	3	ELBOW FITTING 1/2"
23	34396	3	SWIVEL RESTRICTOR
24	21688	3	CAPSCREW 7/16" X 3 1/4"
25	21675	3	HEX NUT 7/16"
26	21635	2	CAPSCREW 3/8" X 2 1/4"
27	21625	2	HEX NUT 3/8"
28	21831	1	CAPSCREW 3/4" X 1 3/4"
29	21825	1	HEX NUT 3/4"
30	06700095	1	CYLINDER SPACER W/SET SCREW
31	*	REF	REFER TO MAIN FRAME

NOTES:

1. ITEM 30 IS USED ON THE GLAND END OF ITEM 2 (AS NEEDED)
2. ORIENTATION OF ITEM 4 IS CRITICAL

60" SIDE CABLE ROTARY MOWER

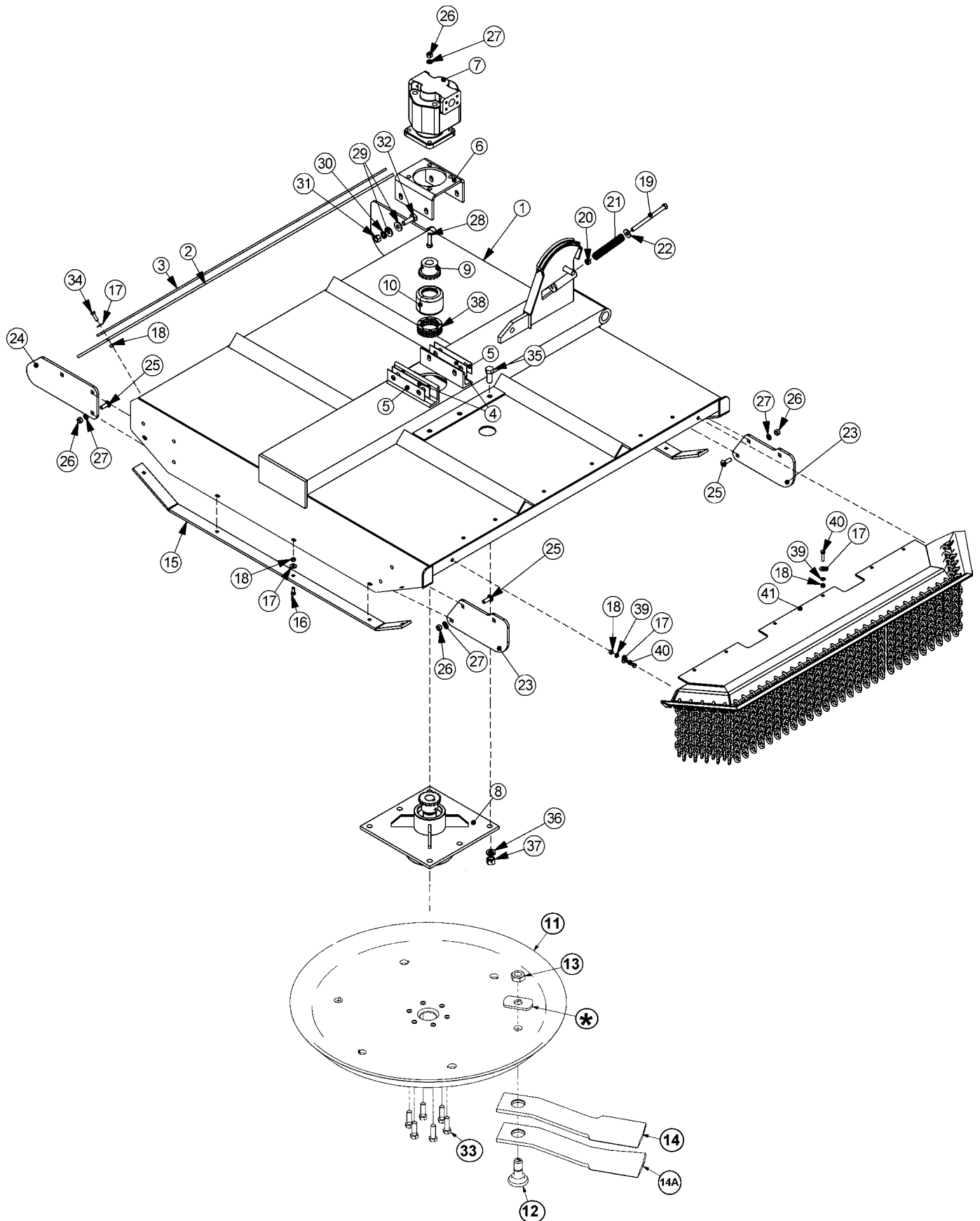

Side Rotary Common Section 6 - 8

60" SIDE CABLE ROTARY MOWER

ITEM	PART NO.	QTY.	DESCRIPTION
1	32099	1	RTRY, 60" WELDMENT, 1/4" DECK
	21225B	1	RTRY, 72" WELDMENT, 1/4" DECK
2	22592	1	FLAP, DEFLECTOR, TM60
3	6T0823	1	BAR, FLAP, TM60
4	6T0822	2	SHIM, MOTOR MOUNT, 14GA. (AS NEEDED)
5	6T0822A	2	SHIM, MOTOR MOUNT, 18 GA. (AS NEEDED)
6	6T1001	1	BRKT, MOTOR MTG, 60"SIDE RTRY
7	06504011	1	CURRENT MOTOR,(M365-2 1/4" GEAR)
	23172	1	ORIGINAL MOTOR,(M365-2 1/4" GEAR)
8	6T1024H5	1	SPINDLE ASSY,CPLT,HD,5/8 HOLES
9	21223	1	SPROKET, 1-1/4" BORE
10	6T1033	1	COVER, COUPLING
11	SEE NEW ROTARY KNIVES AND DISKS PAGE		
12	SEE NEW ROTARY KNIVES AND DISKS PAGE		
13	SEE NEW ROTARY KNIVES AND DISKS PAGE		
14	SEE NEW ROTARY KNIVES AND DISKS PAGE		
14A	SEE NEW ROTARY KNIVES AND DISKS PAGE		
*	SEE NEW ROTARY KNIVES AND DISKS PAGE		
15	6T0820H	2	SKID SHOE, TM60, HEAVY DUTY
16	6T2270	10	PLOW BOLT,3/8" X 1" NC
17	22016	29	FLATWASHER,3/8"
18	21625	29	HEX NUT,3/8",NC
19	21745	1	CAPSCREW, 1/2 x 7,NC
20	21727	1	NYLOCK NUT, 1/2
21	27005	1	SPRING, PUSHOFF, SIDE RTRY
22	22018	1	FLATWASHER,1/2",WIDE
23	33655	2	PLATE,GAURD,SAFETY,FRONT, RTRY
24	33656	1	PLATE,GUARD,SAFETY,REAR,RTRY
25	6T2267	9	CARRIAGE BOLT, 1/2" x 2" NF, GR8
26	21725	13	HEX NUT, 1/2" NC
27	21990	13	LOCKWASHER, 1/2"
28	21733	4	CAPSCREW, 1/2 x 2,NC
29	25270	8	FLATWASHER,5/8", GR 8
30	21992	10	LOCKWASHER, 5/8
31	21775	4	HEX NUT, 5/8
32	21783	4	CAPSCREW, 5/8 x 2,NC
33	6T2290	6	CAPSCREW,5/8x2,NF GR 8
34	21631	11	CAPSCREW, 3/8" x 1-1/4" NC
35	6T2277	6	CAPSCREW, 3/4" x 2" NF
36	21993	6	LOCKWASHER,3/4",GR 8
37	6T2413	6	HEX NUT,3/4,NF,GR 8
38	6T1029	1	CHAIN, COUPLING
39	21988	8	LOCKWASHER, 3/8"
40	21632	8	CAPSCREW,3/8" X 1-1/2" NC
41	31773	1	GAURD,CHAIN,FRONT,SR60

72" SIDE CABLE ROTARY MOWER

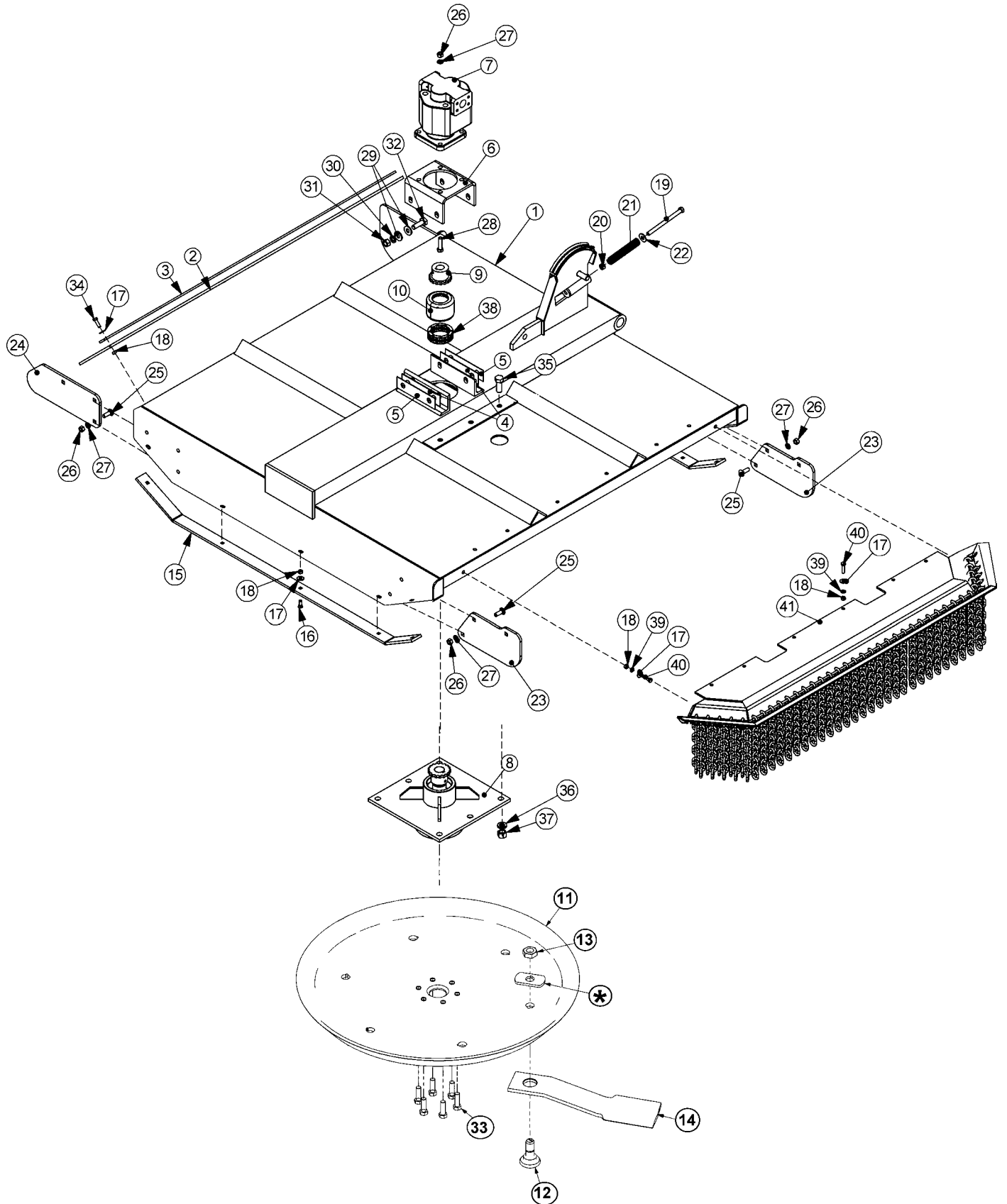

Side Rotary Common Section 6 - 10

72" SIDE CABLE ROTARY MOWER

ITEM	PART NO.	QTY.	DESCRIPTION
1	21225B	1	RTRY, 72" WELDMENT, 1/4" DECK
2	21295B	1	FLAP, DEFLECTOR, TM72
3	21242A	1	BAR, FLAP, TM72
4	6T0822	2	SHIM, MOTOR MOUNT, 14GA. (AS NEEDED)
5	6T0822A	2	SHIM, MOTOR MOUNT, 18 GA. (AS NEEDED)
6	6T1001	1	BRKT, MOTOR MTG, 60"SIDE RTRY
7	06504018	1	CURRENT MOTOR,(M365-2 1/2" GEAR)
	21222	1	ORIGINAL MOTOR,(M365-2 1/2" GEAR)
8	6T1024H5	1	SPINDLE ASSY,CPLT,HD,5/8 HOLES
9	21223	1	SPROKET, 1-1/4" BORE
10	6T1033	1	COVER, COUPLING
11	SEE NEW ROTARY KNIVES AND DISKS PAGE		
12	SEE NEW ROTARY KNIVES AND DISKS PAGE		
13	SEE NEW ROTARY KNIVES AND DISKS PAGE		
14	SEE NEW ROTARY KNIVES AND DISKS PAGE		
*	SEE NEW ROTARY KNIVES AND DISKS PAGE		
15	21248	2	SKID SHOE, TM72
16	6T2270	10	PLOW BOLT,3/8" X 1" NC
17	22016	29	FLATWASHER,3/8"
18	21625	29	HEX NUT,3/8",NC
19	21745	1	CAPSCREW, 1/2 x 7,NC
20	21727	1	NYLOCK NUT, 1/2
21	27005	1	SPRING, PUSHOFF, SIDE RTRY
22	22018	1	FLATWASHER,1/2",WIDE
23	33655	2	PLATE,GAURD,SAFETY,FRONT, RTRY
24	33656	1	PLATE,GUARD,SAFETY,REAR,RTRY
25	6T2267	9	CARRIAGE BOLT, 1/2" x 2" NF, GR8
26	21725	13	HEX NUT, 1/2" NC
27	21990	13	LOCKWASHER, 1/2"
28	21733	4	CAPSCREW, 1/2 x 2,NC
29	25270	8	FLATWASHER,5/8", GR 8
30	21992	10	LOCKWASHER, 5/8
31	21775	4	HEX NUT, 5/8
32	21783	4	CAPSCREW, 5/8 x 2,NC
33	6T2290	6	CAPSCREW,5/8x2,NF GR 8
34	21631	11	CAPSCREW, 3/8" x 1-1/4" NC
35	6T2277	6	CAPSCREW, 3/4" x 2" NF
36	21993	6	LOCKWASHER,3/4",GR 8
37	6T2413	6	HEX NUT,3/4,NF,GR 8
38	6T1029	1	CHAIN, COUPLING
39	21988	8	LOCKWASHER, 3/8"
40	21632	8	CAPSCREW,3/8" X 1-1/2" NC
41	31931	1	GAURD,CHAIN,FRONT,SR72

60" SIDE COMBO ROTARY MOWER

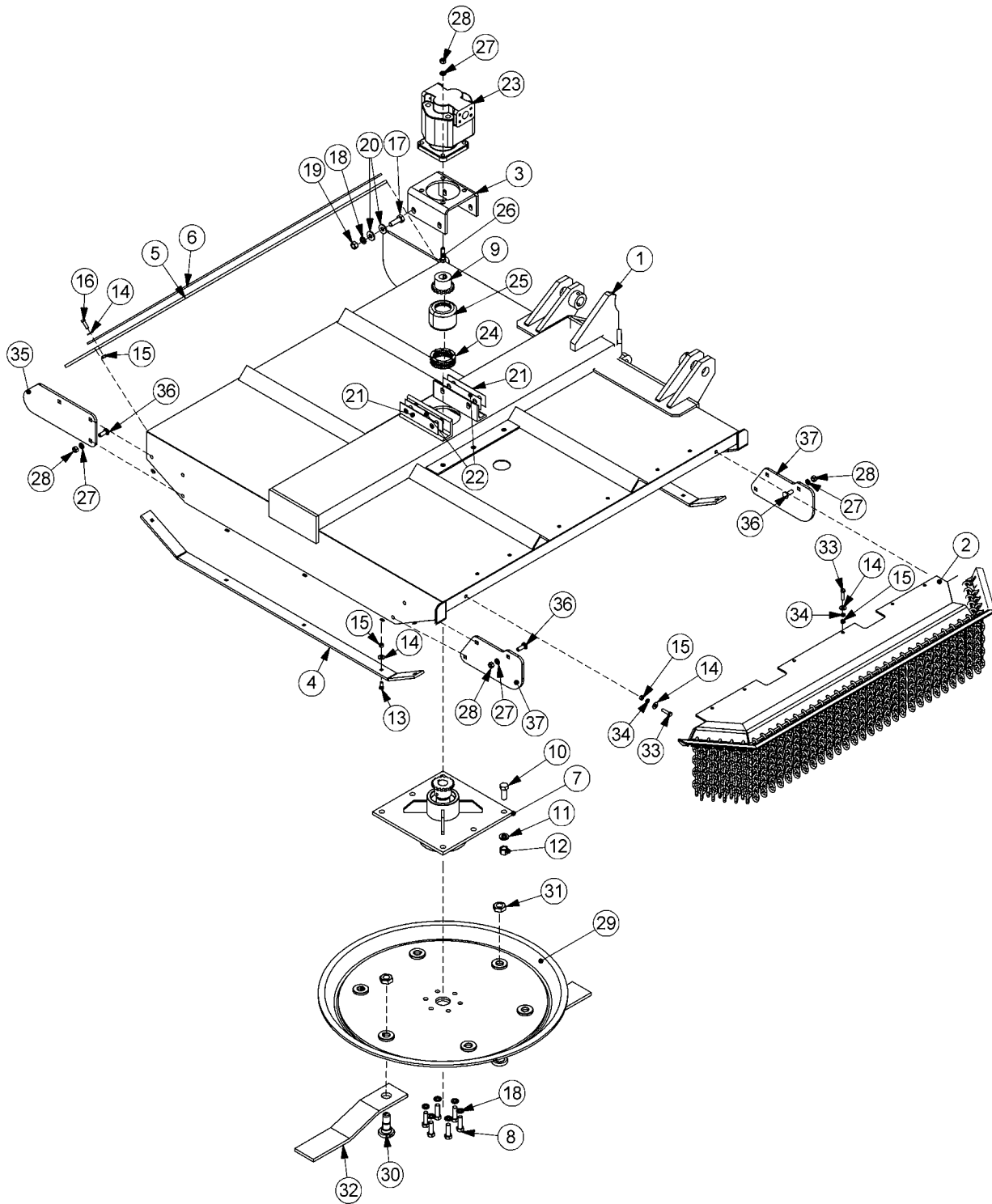

31460

60" SIDE COMBO ROTARY MOWER

ITEM	PART NO.	QTY.	DESCRIPTION
1	32617	1	RTRY, 60" DECK, COMBO - SDT DUTY
	30188D	1	RTRY, 60" DECK, COMBO - HEAVY DUTY
2	31773	1	GAURD,CHAIN,FRONT,SR60
3	6T1001	1	BRKT, MOTOR MTG, 60"SIDE RTRY
4	6T0820H	2	SKID SHOE, TM60, HEAVY DUTY
5	22592	1	FLAP, DEFLECTOR, TM60
6	6T0823	1	BAR, FLAP, TM60
7	6T1024H5	1	SPINDLE ASSY,CPLT,HD,5/8 HOLES
8	6T2290	6	CAPSCREW,5/8x2,NF GR 8
9	21223	1	SPROKET, 1-1/4" BORE
10	6T2277	6	CAPSCREW, 3/4" x 2" NF
11	21993	6	LOCKWASHER,3/4",GR 8
12	6T2413	6	HEX NUT,3/4,NF,GR 8
13	6T2270	10	PLOW BOLT,3/8" X 1" NC
14	22016	29	FLATWASHER,3/8"
15	21625	29	HEX NUT,3/8",NC
16	21631	11	CAPSCREW, 3/8" x 1-1/4" NC
17	21783	4	CAPSCREW, 5/8 x 2,NC
18	21992	10	LOCKWASHER, 5/8
19	21775	4	HEX NUT, 5/8
20	25270	8	FLATWASHER,5/8", GR 8
21	6T0822	2	SHIM, MOTOR MOUNT, 14GA. (AS NEEDED)
22	6T0822A	2	SHIM, MOTOR MOUNT, 18 GA. (AS NEEDED)
23	06504011	1	CURRENT MOTOR,(M365-2 1/4" GEAR)
	23172	1	ORIGINAL MOTOR,(M365-2 1/4" GEAR)
24	6T1029	1	CHAIN, COUPLING
25	6T1033	1	COVER, COUPLING
26	21733	4	CAPSCREW, 1/2 x 2,NC
27	21990	13	LOCKWASHER, 1/2"
28	21725	13	HEX NUT, 1/2" NC
29	SEE OLD ROTARY KNIVES AND DISKS PAGE		
30	SEE OLD ROTARY KNIVES AND DISKS PAGE		
31	SEE OLD ROTARY KNIVES AND DISKS PAGE		
32	SEE OLD ROTARY KNIVES AND DISKS PAGE		
33	21632	8	CAPSCREW,3/8" X 1-1/2" NC
34	21988	8	LOCKWASHER, 3/8"
35	33656	1	PLATE, GUARD, SAFETY, REAR, RTRY
36	6T2267	9	CARRIAGE BOLT, 1/2" x 2" NF, GR8
37	33655	2	PLATE, GAURD, SAFETY, FRONT, RTRY

60" SIDE ROTARY MOWER

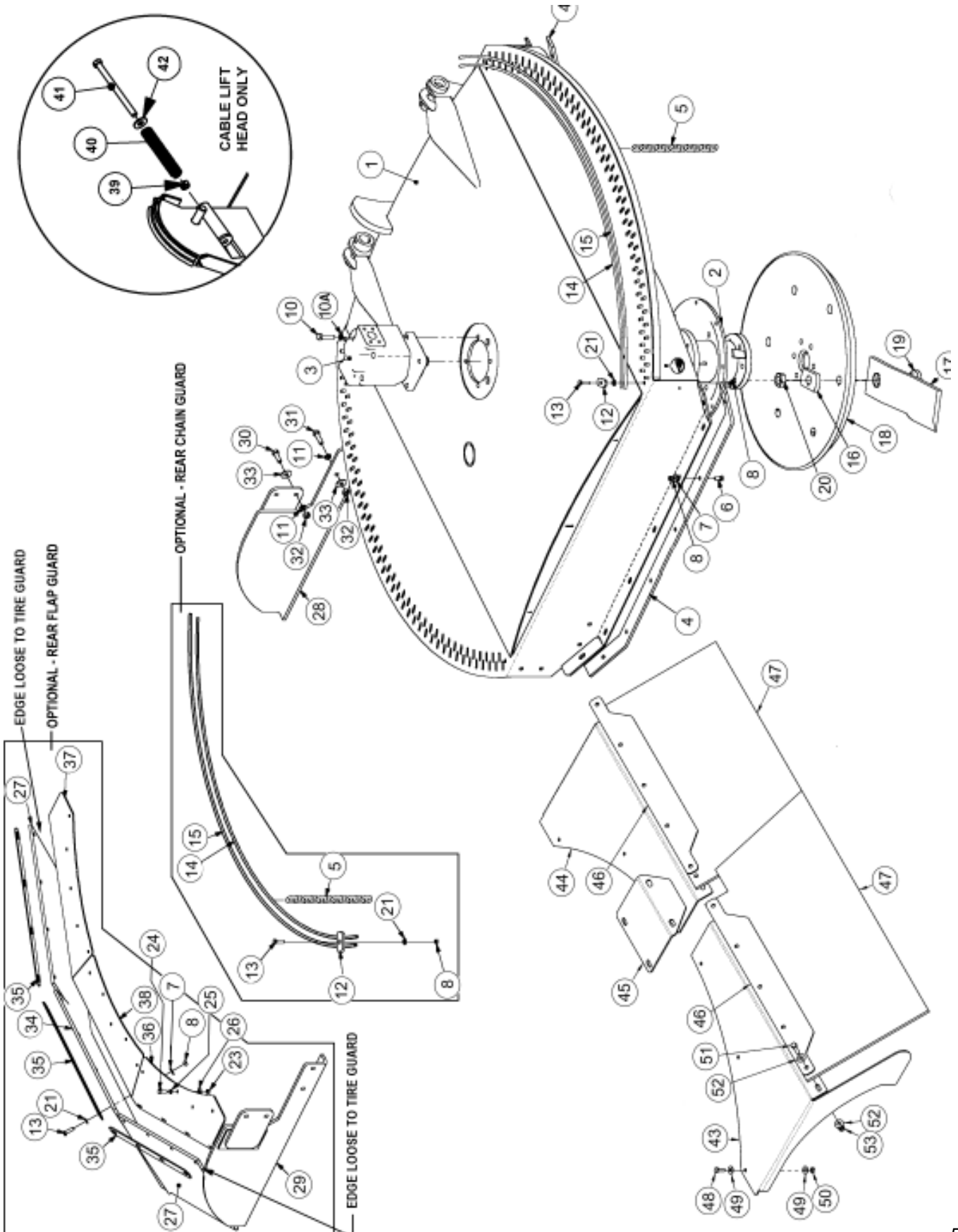

Side Rotary Common Section 6 - 14

60" SIDE ROTARY MOWER

ITEM	PART NO.	QTY.	DESCRIPTION
1	34975	1	HEAVY DUTY GRASSKAT COMBO
	06320005	1	STD DUTY GRASSKAT COMBO
	06320008	1	HEAVY DUTY GRASSKAT CABLE
2	34980	1	SPINDLE ASSY, TM 60"
3	06504016	1	CURRENT MOTOR, (M365-1 1/4" 14-SPLINE)
	34981	1	ORIGINAL MOTOR, (M365-1 1/4" 14-SPLINE)
4	06410254	2	SKID, OUTBOARD, TM60
5	22992	*156	CHAIN, 10 LINK
6	6T2270	14	PLOW BOLT, 3/8" X 1" NC
7	22016	*26	FLATWASHER, 3/8"
8	21625	*30	HEX NUT, 3/8", NC
10	6T1025	4	CAPSCREW, 1/2 x 2, GR 8, NC
10A	06533006	4	FLATWASHER, 1/2, SAE, GR 8
11	21990	*8	LOCKWASHER, 1/2"
12	34972	*4	PLATE, CAP, CHAIN
13	21631	*16	CAPSCREW, 3/8 x 1-1/4, NC
14	34974	*2	ROD, CHAIN, INNER, TM60
15	34973	*2	ROD, CHAIN, OUTER, TM60
16 - 20	SEE NEW ROTARY KNIVES AND DISKS PAGE		
21	21988	*16	LOCKWASHER, 3/8"
22	6T2290	6	CAPSCREW, 5/8x 1-3/4 (NOT SHOWN)
23	21575	*25	HEX NUT, 5/16", NC
24	21580	*25	CAPSCREW, 5/16" x 1" NC
25	21987	*25	LOCKWASHER, 5/16"
26	22015	*25	FLATWASHER, 5/16"
27	06520084	*2	ROTARY SIDE FLAP
28	06370029	1	TIRE GUARD, LEFT
29	06370030	*1	TIRE GUARD, RIGHT
30	21731	*4	CAPSCREW, 1/2" x 1-1/2" NC
31	21732	*4	CAPSCREW, 1/2" x 1-3/4" NC
32	21725	*8	HEX NUT, 1/2", NC
33	22018	*8	FLATWASHER, 1/2", WIDE
34	06520085	*1	ROTARY CENTER FLAP
35	06400207	*3	ROTARY FLAP STRAP
36	06410207	*1	FLAP MOUNT, RIGHT
37	06410206	*1	FLAP MOUNT, LEFT
38	06410208	*1	FLAP MOUNT, CENTER
	CABLE LIFT HEAD ONLY		
39	21745	1	NYLOCK NUT, 1/2
40	21727	1	SPRING, PUSHOFF, SIDE RTRY
41	27005	1	CAPSCREW, 1/2 x 7, NC
42	22018	1	FLATWASHER, 1/2", WIDE
	OPTIONAL SQUARE FLAP		
43	06410946	1	MNT, FLAP, LH, EXT, TSR
44	06410947	1	MNT, FLAP, RH, EXT, TSR
45	06410948	1	COVER, FLAP, EXT, TSR
46	06401184	2	STRAP, FLAP, EXT, TSR
47	06520331	2	FLAP, EXT, TSR
48	21580	6	CAPSCREW, 5/16 X 1 NC
49	22015	12	FLATWASHER, 5/16
50	21575	6	HEX NUT, 5/16, NC
51	21632	10	CAPSCREW, 3/8" X 1-1/2" NC
52	22016	20	FLATWASHER, 3/8", GR8
53	21625	10	HEX NUT, 3/8", NC

* QUANTITY VARIES - REAR CHAIN GUARD & REAR FLAP GUARD IS OPTIONAL.
STANDARD UNIT COMES WITH FRONT CHAINS AND LEFT TIRE GUARD

60" SIDE ROTARY SPINDLE AND SPACER

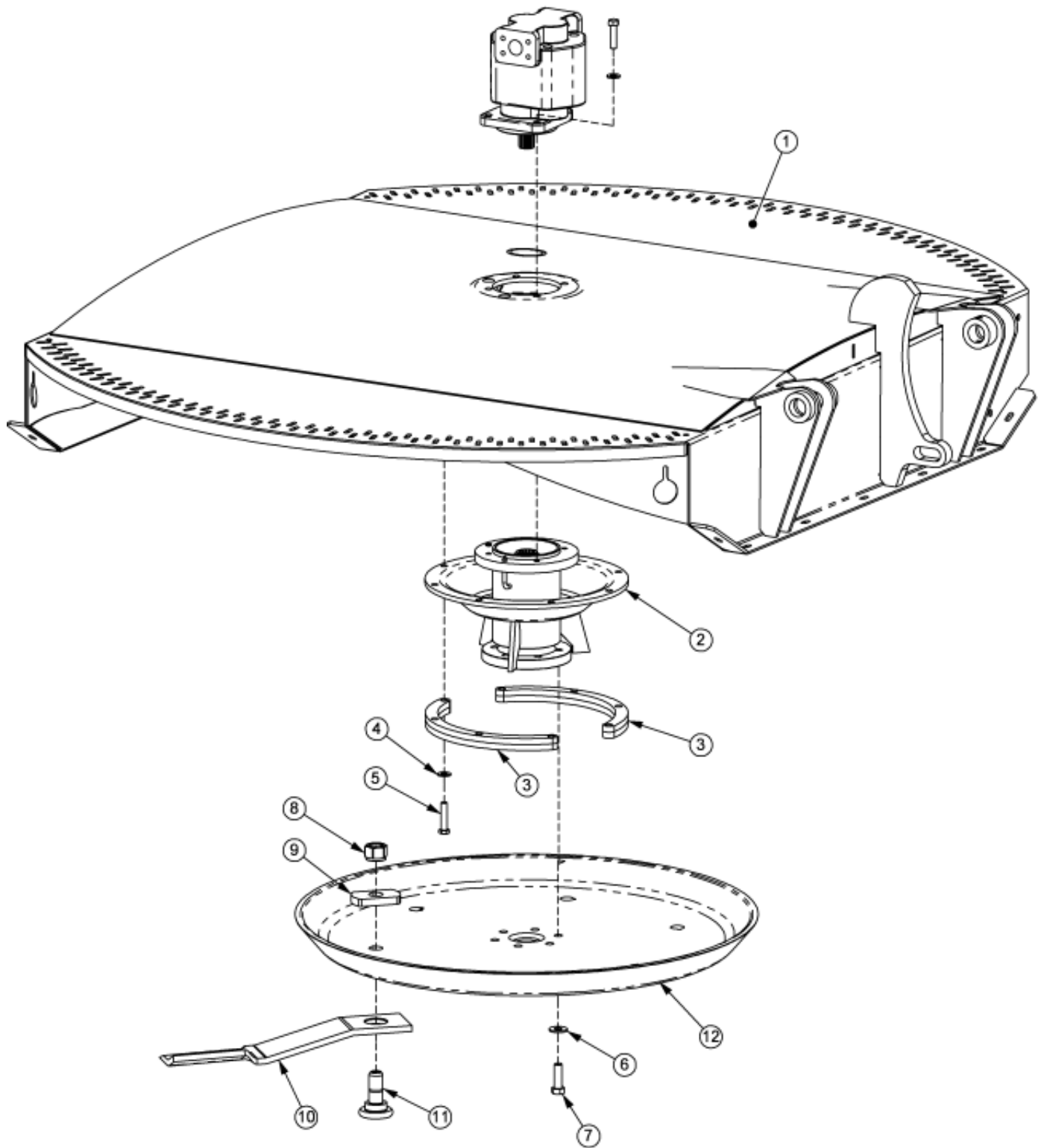

60" SIDE ROTARY SPINDLE AND SPACER

ITEM	PART NO.	QTY.	DESCRIPTION
1	34975	1	HEAVY DUTY GRASSKAT COMBO
	06320005	1	STD DUTY GRASSKAT COMBO
	06320008	1	HEAVY DUTY GRASSKAT CABLE
2	34980	1	SPINDLE ASSY, TM 60"
3	06320011	2	SPACER, TSR, SPINDLE
4	06533004	8	FLATWASHER, 1/2, SAE, GR 8
5	06530221	8	CAPSCREW, 1/2 x 2-1/4, NF GR 8
6	25270	6	FLATWASHER, 5/8, USS, GR8
7	6T2290	6	CAPSCREW, 5/8 x 2, NF GR8
8			SEE NEW ROTARY KNIVES AND DISKS PAGE
9			SEE NEW ROTARY KNIVES AND DISKS PAGE
10			SEE NEW ROTARY KNIVES AND DISKS PAGE
11			SEE NEW ROTARY KNIVES AND DISKS PAGE
12			SEE NEW ROTARY KNIVES AND DISKS PAGE

72" SIDE COMBO ROTARY MOWER

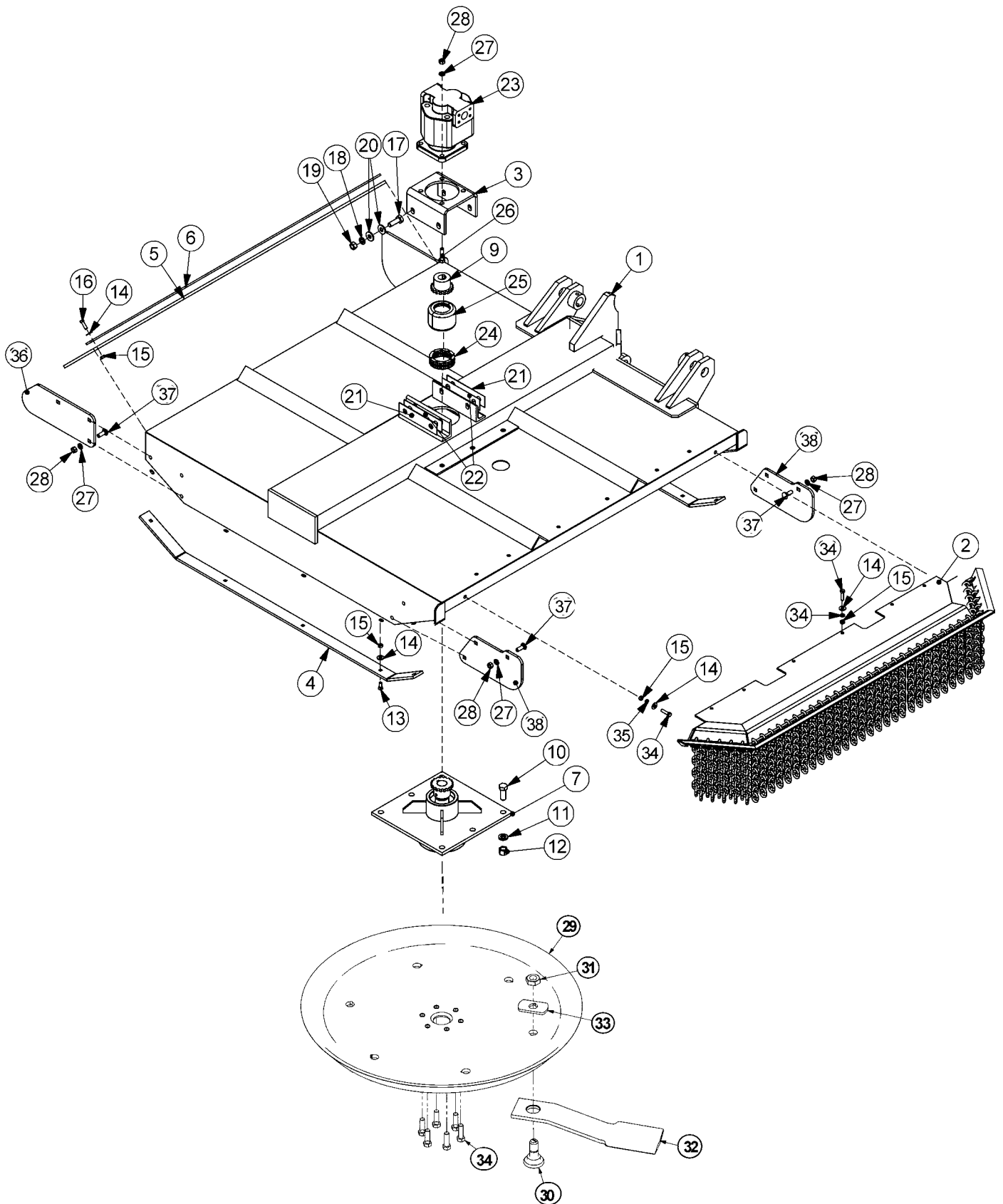

Side Rotary Common Section 6 - 18

72" SIDE COMBO ROTARY MOWER

ITEM	PART NO.	QTY.	DESCRIPTION
1	34260	1	RTRY, 72" DECK, COMBO - SDT DUTY
	31408A	1	RTRY, 72" DECK, COMBO - HEAVY DUTY
2	31931	1	GAURD,CHAIN,FRONT,SR60
3	6T1001	1	BRKT, MOTOR MTG, 60"SIDE RTRY
4	21248	2	SKID SHOE, TM72
5	21295B	1	FLAP, DEFLECTOR, TM72
6	21242A	1	BAR, FLAP, TM72
7	6T1024H5	1	SPINDLE ASSY,CPLT,HD,5/8 HOLES
8	6T2290	6	CAPSCREW,5/8x2,NF GR 8
9	21223	1	SPROKET, 1-1/4" BORE
10	6T2277	6	CAPSCREW, 3/4" x 2" NF
11	21993	6	LOCKWASHER,3/4",GR 8
12	6T2413	6	HEX NUT,3/4,NF,GR 8
13	6T2270	10	PLOW BOLT,3/8" X 1" NC
14	22016	29	FLATWASHER,3/8"
15	21625	29	HEX NUT,3/8",NC
16	21631	11	CAPSCREW, 3/8" x 1-1/4" NC
17	21783	4	CAPSCREW, 5/8 x 2,NC
18	21992	10	LOCKWASHER, 5/8
19	21775	4	HEX NUT, 5/8
20	25270	8	FLATWASHER,5/8", GR 8
21	6T0822	2	SHIM, MOTOR MOUNT, 14GA. (AS NEEDED)
22	6T0822A	2	SHIM, MOTOR MOUNT, 18 GA. (AS NEEDED)
23	06504018	1	CURRENT MOTOR,(M365-2 1/2" GEAR)
	21222	1	ORIGINAL MOTOR,(M365-2 1/2" GEAR)
24	6T1029	1	CHAIN, COUPLING
25	6T1033	1	COVER, COUPLING
26	21733	4	CAPSCREW, 1/2 x 2,NC
27	21990	13	LOCKWASHER, 1/2"
28	21725	13	HEX NUT, 1/2" NC
29	SEE NEW ROTARY KNIVES AND DISKS PAGE		
30	SEE NEW ROTARY KNIVES AND DISKS PAGE		
31	SEE NEW ROTARY KNIVES AND DISKS PAGE		
32	SEE NEW ROTARY KNIVES AND DISKS PAGE		
33	SEE NEW ROTARY KNIVES AND DISKS PAGE		
34	21632	8	CAPSCREW,3/8" X 1-1/2" NC
35	21988	8	LOCKWASHER, 3/8"
36	33656	1	PLATE,GUARD,SAFETY,REAR,RTRY
37	6T2267	9	CARRIAGE BOLT, 1/2" x 2" NF, GR8
38	33655	2	PLATE,GAURD,SAFETY,FRONT, RTRY

TM72" MOTOR ASSEMBLY

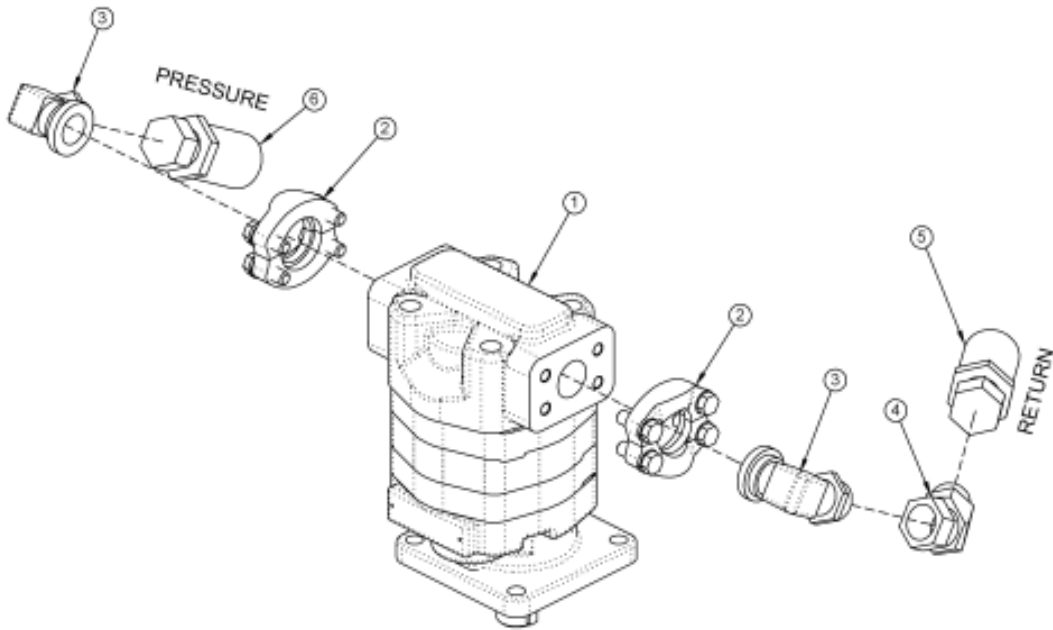

ITEM	PART NO.	QTY.	DESCRIPTION
1	06504018	1	MOTOR
2	TF4852	2	KIT,FLANGE,#20
3	34943	2	ELBOW,#20FLG x #16MJ
4	24724	1	ELBOW,#16FJX x #16MJ45
5	06500444	1	HOSE,#16 x 141
6	06500445	1	HOSE,#16 x 145

PAGE
INTENTIONALLY
LEFT
BLANK

CHAIN GUARDS

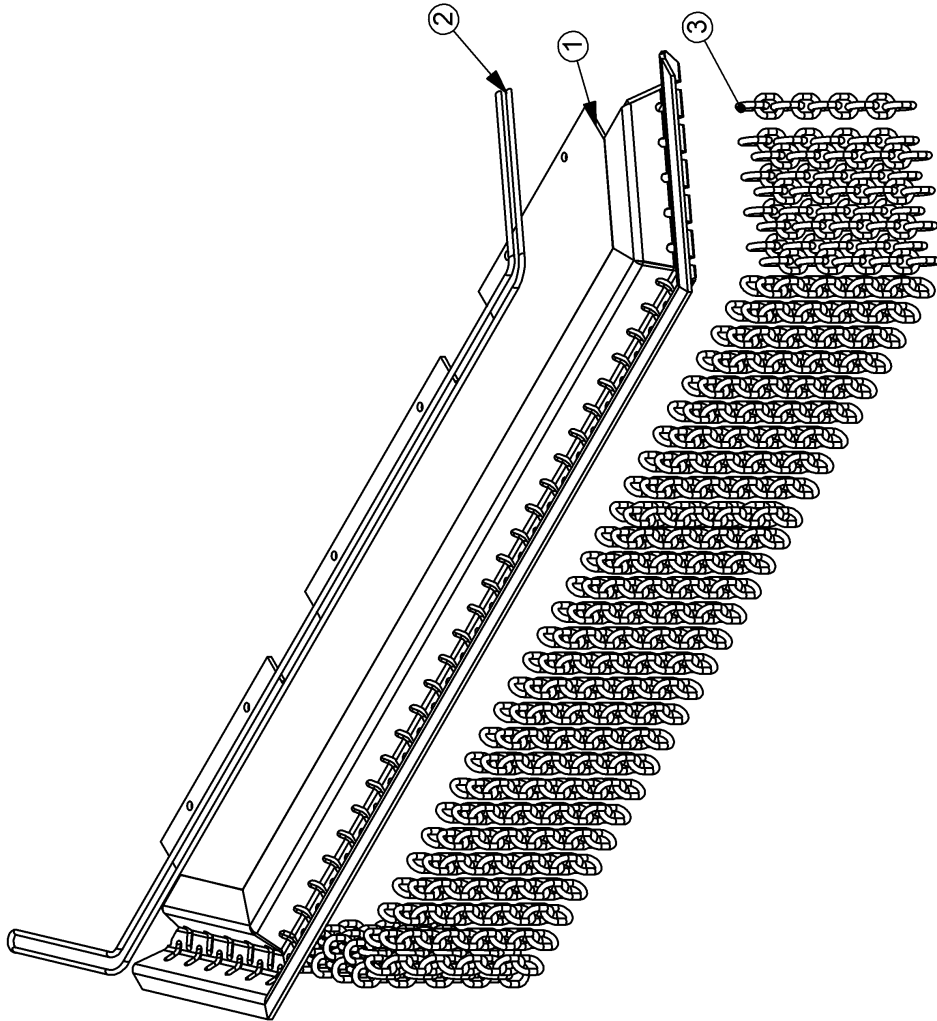

SIDE ROTARY CHAIN GUARDS

60" SIDE ROTARY

ITEM	PART NO.	QTY.	DESCRIPTION
	31773	STD.	GAURD,CHAIN,SR60,FRONT ASSY
1	31762	1	GUARD,CHAIN,TM60,FRONT
2	28407	12'	CABLE, 5/16", BULK
3	22993	77	CHAIN, 5/16" GR30, 9 LINK
**	28408	4	U-BOLT, CABLE, 5/16"

** NOT SHOWN

72" SIDE ROTARY

ITEM	PART NO.	QTY.	DESCRIPTION
	31931	STD.	GAURD,CHAIN,SR72,FRONT ASSY
1	31863	1	GUARD,CHAIN,TM72,FRONT
2	28407	14'	CABLE, 5/16", BULK
3	22993	91	CHAIN, 5/16" GR30, 9 LINK
**	28408	4	U-BOLT, CABLE, 5/16"

** NOT SHOWN

SIDE ROTARY CASTER WHEEL ASSEMBLY

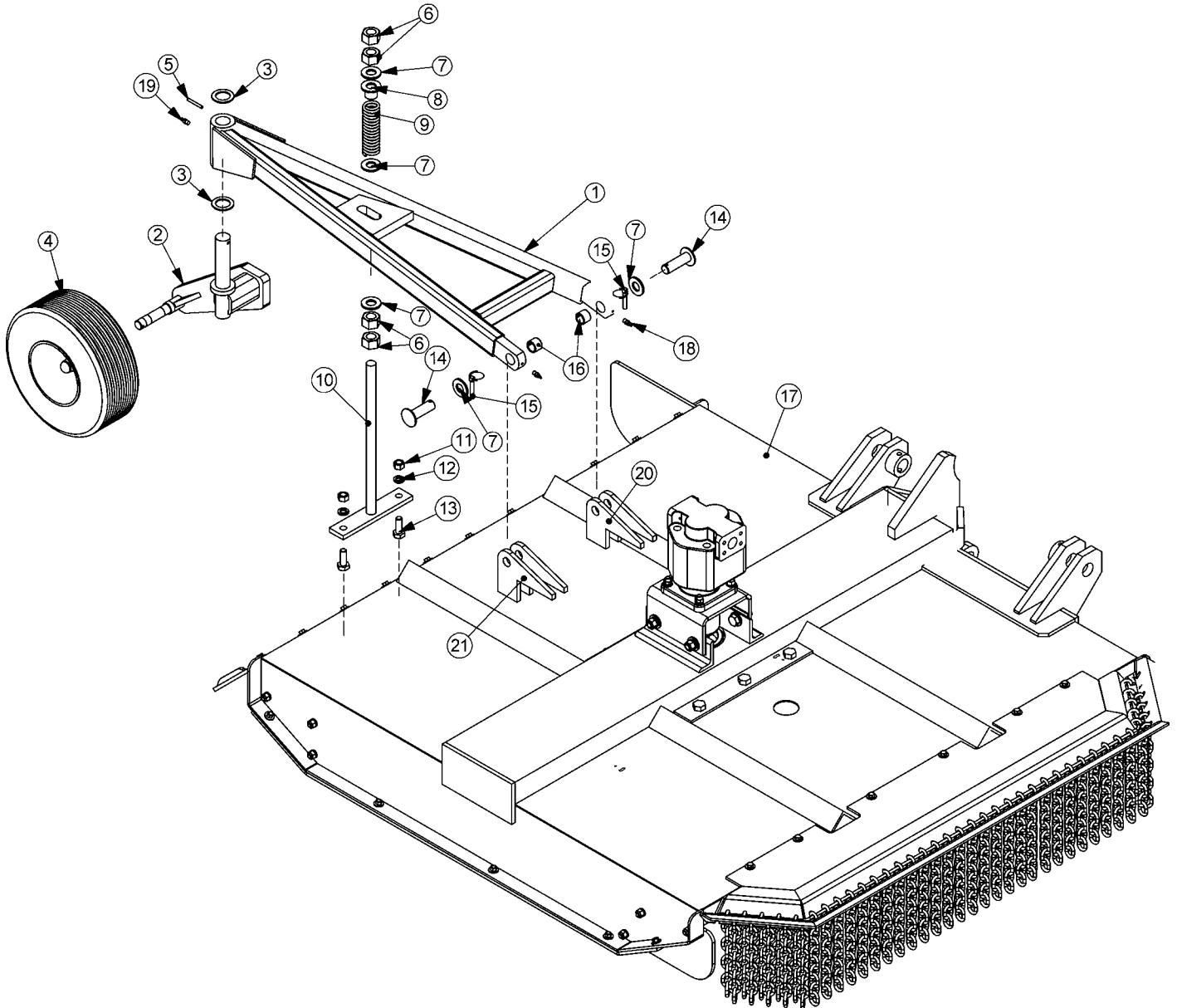

PB80100 CASTER WHEEL SIDE RTRY

SIDE ROTARY CASTER WHEEL ASSEMBLY

ITEM	PART NO.	QTY.	DESCRIPTION
1	25214C	1	FRAME,CASTER,WHL,TM60,W/O CG
2	22057C	1	SPINDLE, CASTER AXLE, ASSY
3	6T2617	2	BUSHING,MACH,1-1/2IDX 2-1/4OD
4	28548	1	CASTER WHEEL, SOLID TIRE
**	22065	1	HUB ASSY, REAR ROTARY
**	22066	1	HUB, CASTER (REAR ROTARY)
**	22070	1	DUST CAP
**	22071	5	HUB STUD
**	22073	1	HEX NUT, 1"NF (SLOTTED)
**	22533	1	COTTER PIN, 3/16" x 2"
**	6T0830	2	BEARING, CONE, CASTER WHEEL
**	6T0838	1	SEAL
**	23329	1	WHEEL, CPLT, SOLID TIRE
**	21416	1	TIRE, SOLID, RR-RTRY
**	22697	1	RIM, OUTER/RR RTRY CASTER
**	22696	1	RIM, REAR ROTARY CASTER
5	6T3014	1	ROLL PIN, 1/4" x 2"
6	21925	4	HEX NUT,1" NC
7	22023	5	FLATWASHER,1"
8	22753	1	TUBE, PROTECTOR
9	22058	1	SPRING, REAR RTRY
10	22059B	1	ADJ ROD, TRR
11	21775	2	HEX NUT, 5/8
12	21992	2	LOCKWASHER, 5/8
13	21782	2	CAPSCREW, 5/8 x 1 3/4,NC
14	22060	2	CASTER FRAME PIN
15	TF1143	2	PIN, LYNCH, 7/16" x 2"
16	TB3010	2	BUSHING,1"
17	31460	1	RTRY,60" CPLT-HP,T3F,W/FRT CG
18	6T3207	2	GREASE ZERK,1/4" X STR
19	6T3211	1	GREASE ZERK,1/8" X STR
20	21441	2	CASTER FRAME ANCHOR GUSSET
21	21442	2	CASTER FRAME ANCHOR GUSSET

NOTE: CASTER WHEEL ASSEMBLY IS BROKEN DOWN LATER IN THE MANUAL

RESERVOIR TANK FILTER ASSEMBLY

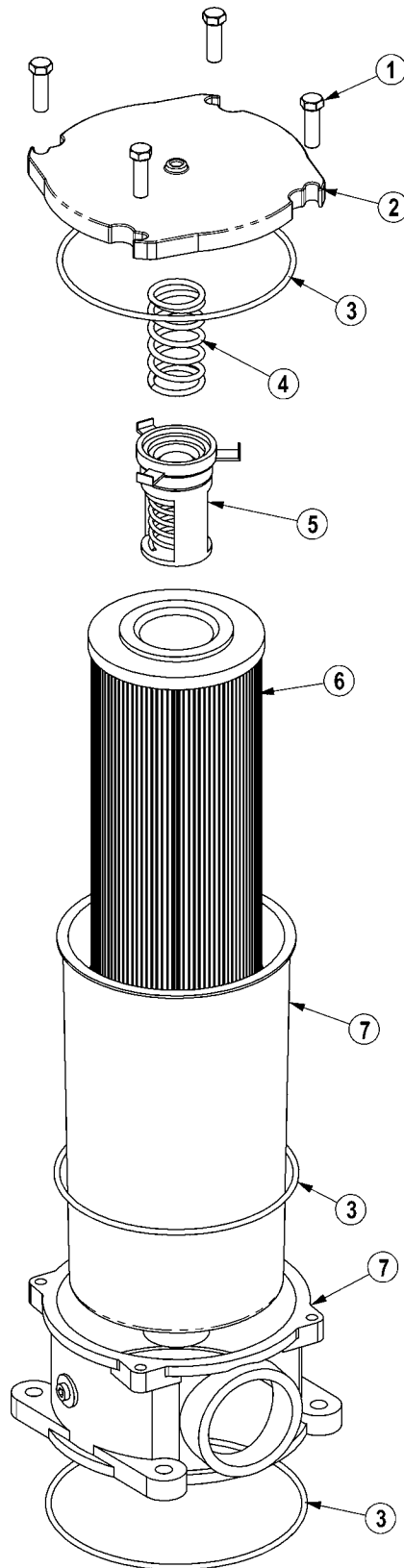

RESERVOIR TANK FILTER ASSEMBLY

ITEM	PART NO.	QTY.	DESCRIPTION
	06505044	AVAIL	FILTER ASSY SAE 10 MICRON
1	28583	4	CAPSCREW,8MMX25MM(1.25 PITCH)
2	06505045	1	COVER
3	06505046	1	SEAL KIT
4	06505047	1	SPRING
5	06505048	1	BYPASS
6	35259	1	FILTER,10 MIC,RETURN LINE
7	06505049	1	CAN/BODY

MOWER SPINDLE ASSEMBLY - 6T1024H5

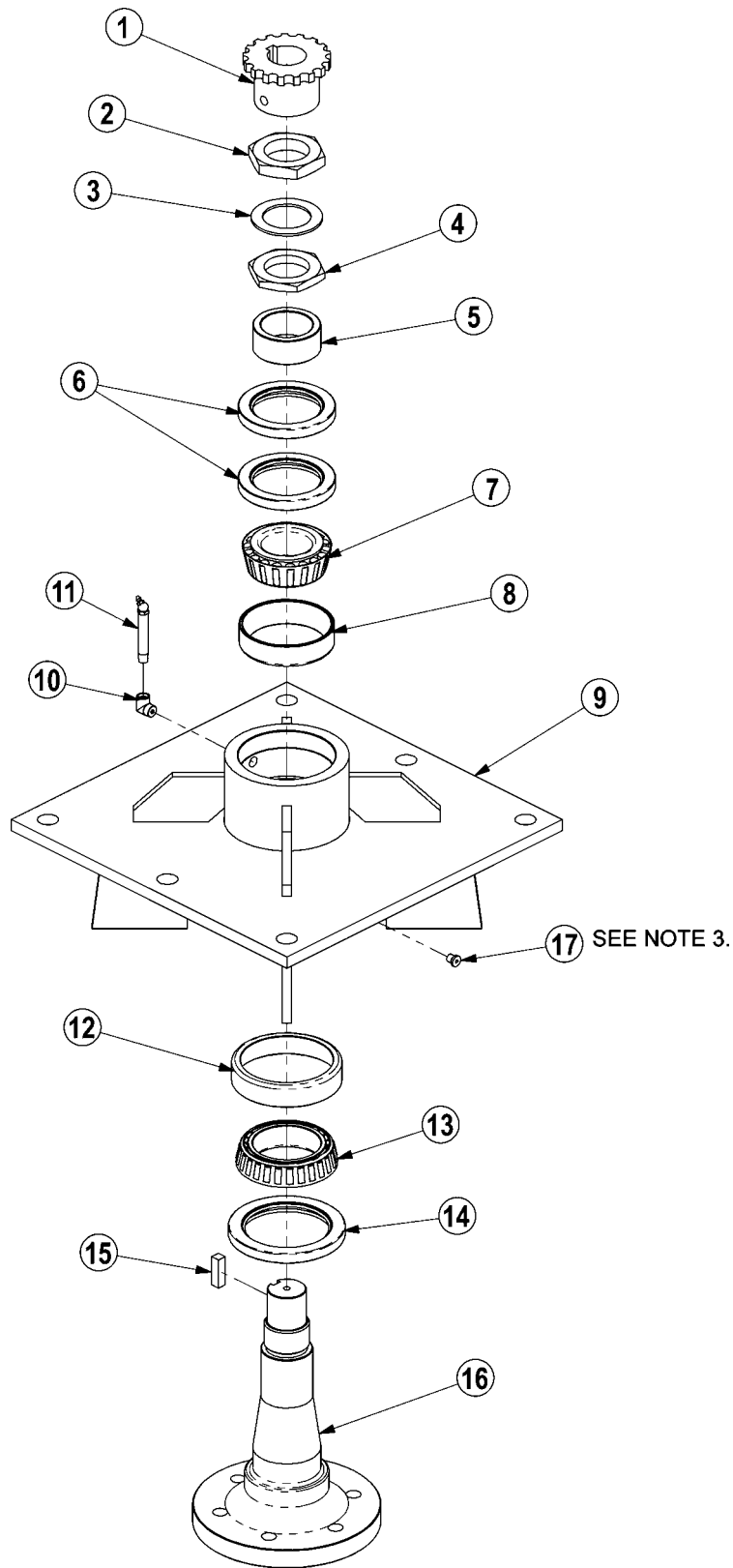

NOTES:

1. FREEPLAY: .001" - .003"
 2. GREASE: FILL WITH MOBILITH SHC 220.
 3. APPLY LOCTITE "271" TO O-RING PLUG THRDS.
- Side Rotary Common Section 6 - 28**

MOWER SPINDLE ASSEMBLY - 6T1024H5

ITEM	PART NO.	QTY.	DESCRIPTION
	6T1024H5	AVAIL	SPINDLE ASSEMBLY COMPLETE
1	6T1031	1	SPROCKET
2	6T1016	1	BEARING LOCK NUT - THICK
3	22596	1	JAM WASHER
4	6T1015	1	BEARING ADJUSTMENT NUT - THIN
5	6T1014	1	BEARING ADJUSTMENT SLEEVE
6	6T1011	1	UPPER SEAL - SET OF 2
7	6T1012	1	BEARING CONE
8	6T1013	1	BEARING CUP
9	6T1010H	1	SPINDLE HOUSING
10	30570	1	FITTING STREET ELBOW
11	33990	1	GREASE ZERK
12	6T1013H	1	BEARING CUP
13	6T1012H	1	BEARING CONE
14	6T1011H	1	LOWER SEAL
15	6T1019	1	SPINDLE KEY
16	PT1018H-5	1	SPINDLE
17	06503064	1	O-RING PLUG, 1/8"
*	32572	AVAIL	SPINDLE REBUILD KIT (INCLUDE ITEMS 2 THRU 8 AND 12 THRU 15)

MOWER SPINDLE ASSEMBLY - 34980

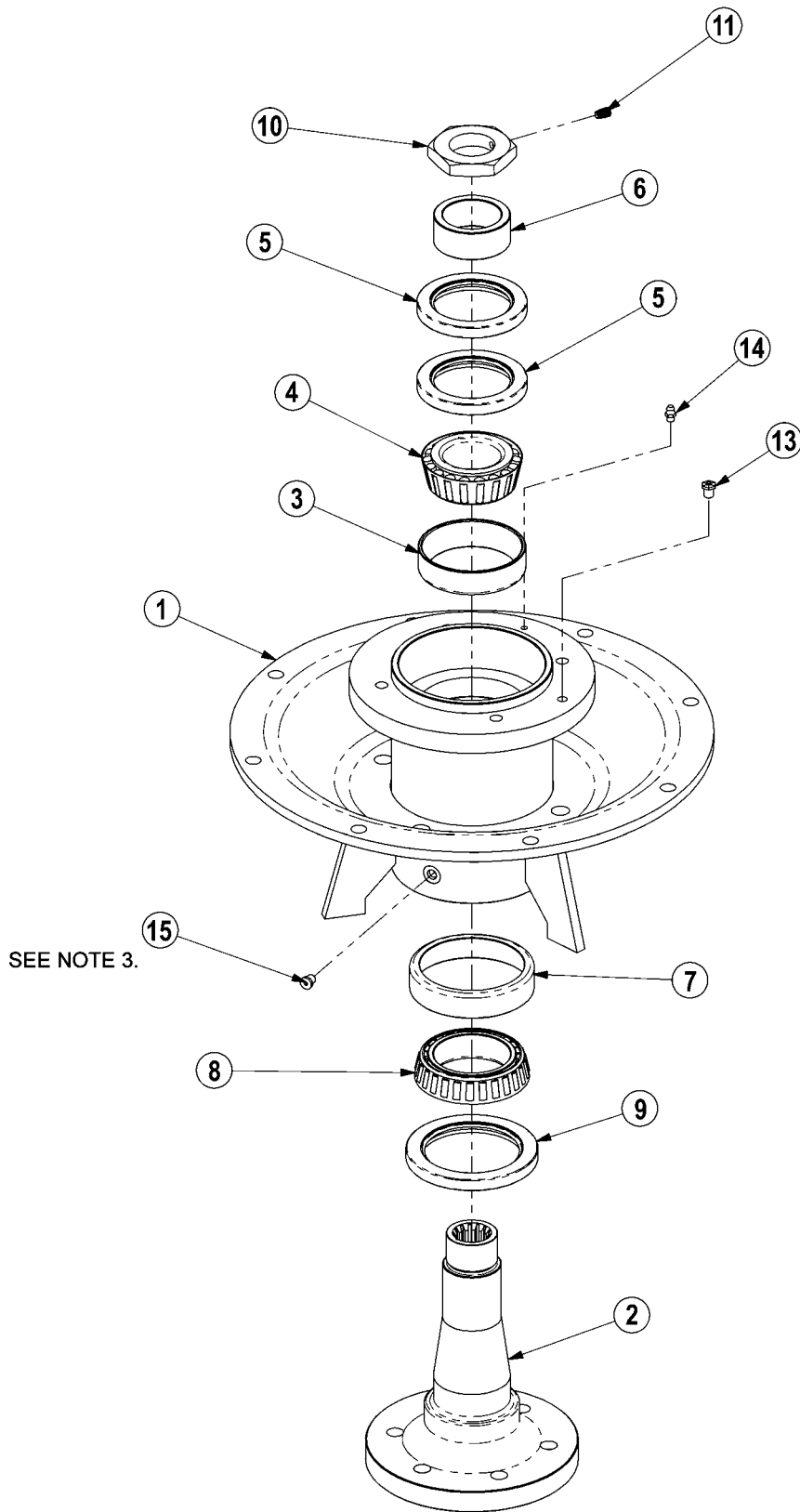

NOTES:

1. FREEPLAY: .001" - .003"
2. GREASE: FILL WITH MOBILITH SHC 220.
3. APPLY LOCTITE "271" TO O-RING PLUG THRDS.

MOWER SPINDLE ASSEMBLY - 34980

ITEM	PART NO.	QTY.	DESCRIPTION
1	34978	1	SPINDLE MOUNT
2	34979	1	SPINDLE, TM60", NEW
3	6T1013	1	BEARING CUP
4	6T1012	1	BEARING, CONE
5	6T1011	2	SEAL, UPPER (SET OF 2)
6	6T1014	1	SLEEVE, ADJ BEARING
7	6T1013H	1	BEARING CUP, HD
8	6T1012H	1	BEARING, CONE, HD
9	6T1011H	1	SEAL, LOWER (HD)
10	34985	1	NUT W/ SETSCREW
11	6T2275	1	SETSCREW, 5/16x1/2, NC
13	34988	1	RELIEF, 1PSI, 1/8NPT
14	6T3207	1	ZERK, 1/4" x STR
15	06503064	1	O-RING PLUG, 1/8"

HYDRAULIC LIFT CYLINDER

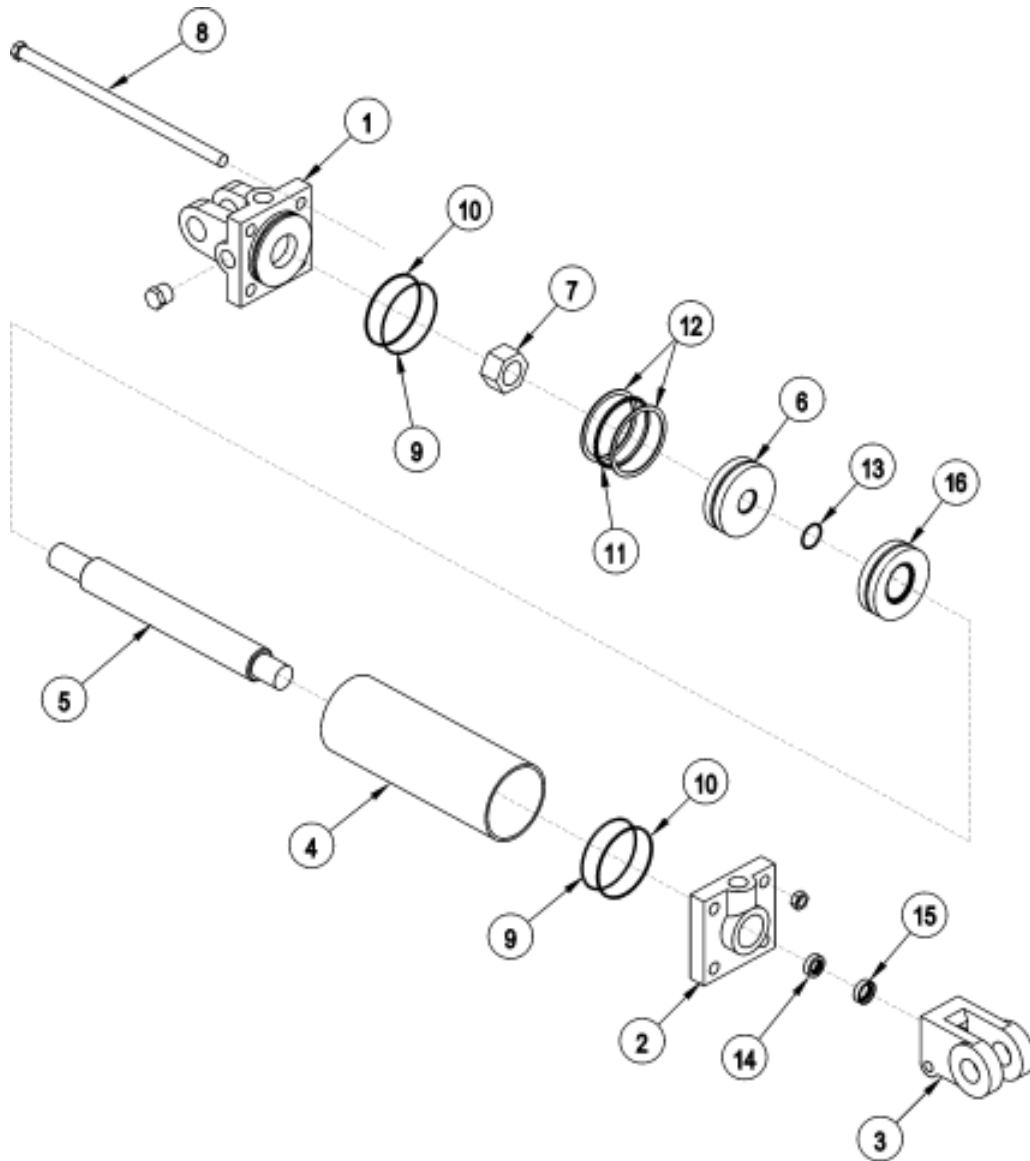

Tb1015

HYDRAULIC LIFT CYLINDER

3" X 10" CYLINDER # 6T0151R

ITEM	PART NO.	QTY.	DESCRIPTION
1	6T0167	1	CYLINDER BUTT
2	6T0170	1	CYLINDER GLAND
3	6T0178	1	CLEVIS END
4	6T0164	1	CYLINDER TUBE
5	6T0161	1	PISTON ROD
6	6T0173	1	PISTON
7	6T0179	1	LOCKNUT
8	6T0176	4	TIE ROD ASY
	6T0187	AVAIL	SEAL KIT
9		2	O - RING
10		2	BACK - UP WASHER
11		1	O - RING
12		2	BACK - UP WASHER
13		1	O - RING
14		1	U - CUP
15		1	WIPER

3" X 12" CYLINDER # 32215

ITEM	PART NO.	QTY.	DESCRIPTION
1	6T0167	1	CYLINDER BUTT
2	6T0170	1	CYLINDER GLAND
3	6T0178	1	CLEVIS END
4	6T0204	1	CYLINDER TUBE
5	6T0203	1	PISTON ROD
6	6T0173	1	PISTON
7	6T0179	1	LOCKNUT
8	6T0205	1	TIE ROD ASY
	6T0187	AVAIL	SEAL KIT
9		2	O - RING
10		2	BACK - UP WASHER
11		1	O - RING
12		2	BACK - UP WASHER
13		1	O - RING
14		1	U - CUP
15		1	WIPER

3" X 18" CYLINDER # 6T0150

ITEM	PART NO.	QTY.	DESCRIPTION
1	6T0167	1	CYLINDER BUTT
2	6T0170	1	CYLINDER GLAND
3	6T0178	1	CLEVIS END
4	6T0165	1	CYLINDER TUBE
5	6T0162	1	PISTON ROD
6	6T0173	1	PISTON
7	6T0179	1	LOCKNUT
8	6T0177	1	TIE ROD ASY
	6T0187	AVAIL	SEAL KIT
9		2	O - RING
10		2	BACK - UP WASHER
11		1	O - RING
12		2	BACK - UP WASHER
13		1	O - RING
14		1	U - CUP
15		1	WIPER

ROTARY KNIVES AND DISKS

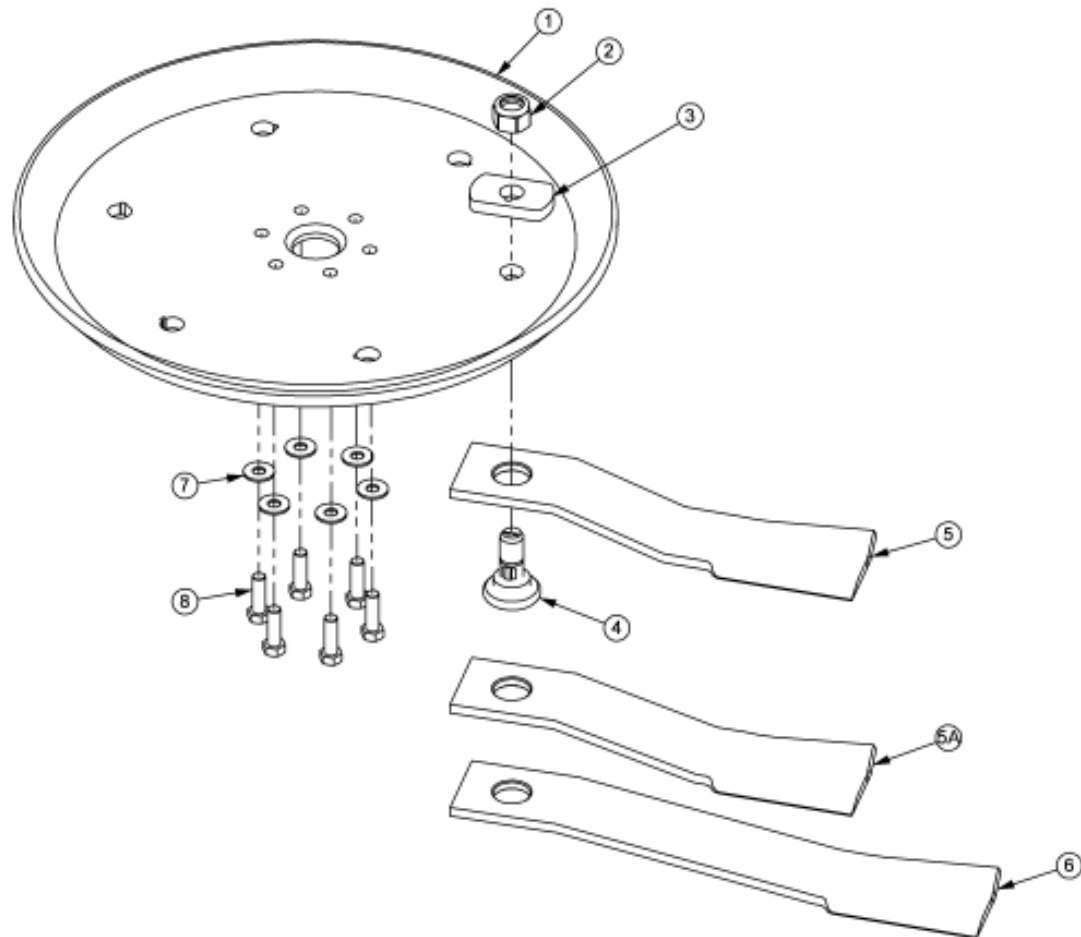

ITEM	PART NO.	QTY.	DESCRIPTION
1	34876	1	BLADE MOUNTING DISK
2	6T1023R	2	NYLOCK HEX NUT 1 1/8"
3	34878	2	SPACER
4	34497	2	KNIFE MOUNTING BOLT
5	34685	2	KNIFE,60" HIGH SUCTION - STANDARD
5A	34684	2	KNIFE,60" - OPTIONAL
6	34682	2	KNIFE 72" - MOUNT ON 72" MOWER ONLY
7	25270	6	FLATWASHER,5/8,USS,GR8
8	6T2290	6	CAPSCREW,5/8 x 2
*	6T1825	*	LOCTITE - USED ON ALL DISK MOUNTING BOLTS
*	27167	AVAIL	BOLT KIT (INCLUDE ITEMS 7 & 8)
*	06700002	AVAIL	KIT,60/72,DISK,KNF MTG (INCLUDE ITEM 1, 3,7 & 8)

CASTER WHEEL ASSEMBLY

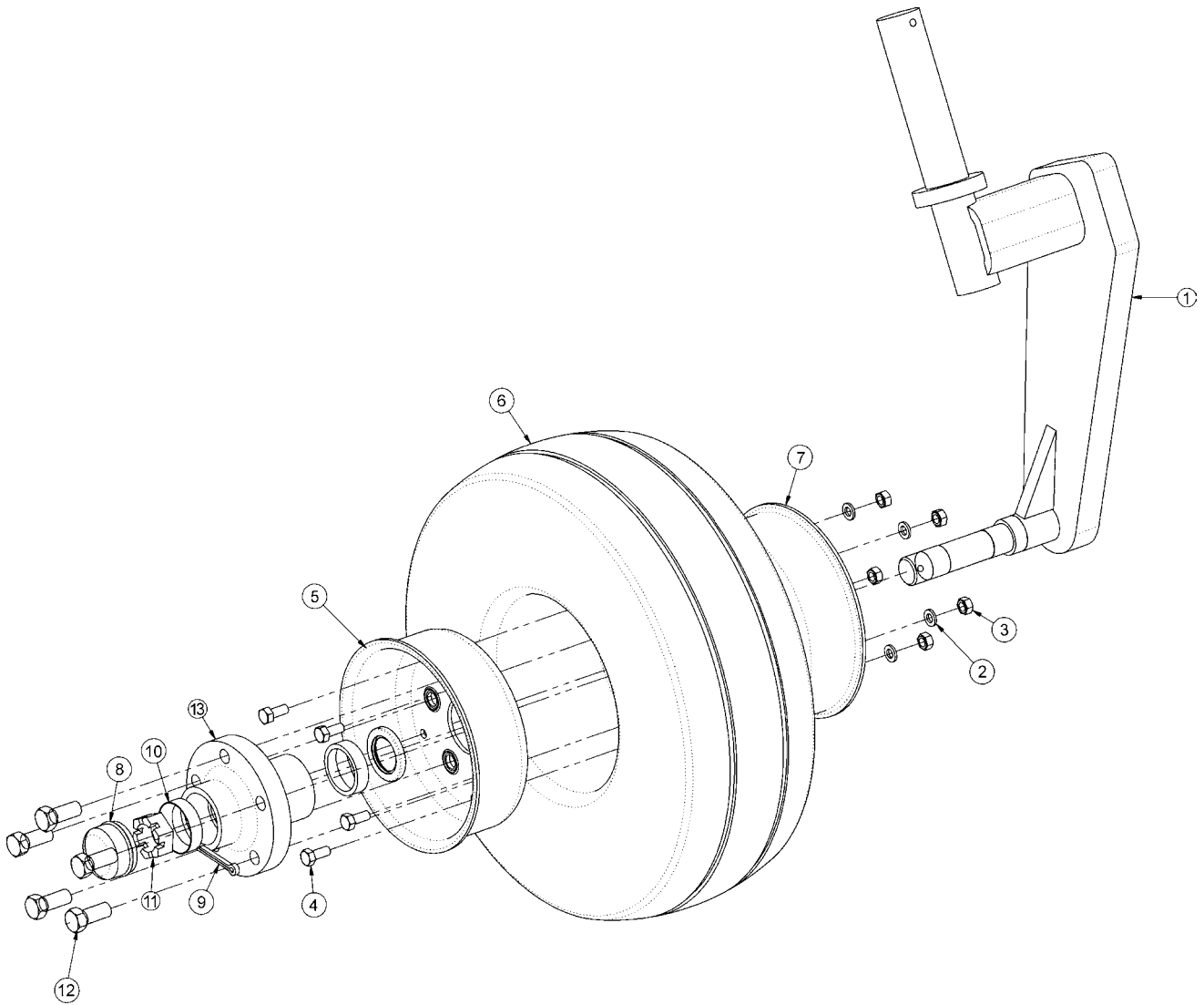

ITEM	PART NO.	QTY.	DESCRIPTION
1	21459	1	SPINDLE, CASTER WHEEL AXLE
2	21987	5	LOCKWASHER, 5/16"
3	21575	5	HEX NUT, 5/16"
4	28548	5	CAPSCREW, 5/16" x 3/4", NC
5	22697-1	1	RIM, OUTER/RR RTRY CASTER ASSY
6	21416	1	TIRE, SOLID, RR-RTRY
7	22696-1	1	RIM, REAR ROTARY CASTER
8	22070	1	DUST CAP
9	22533	1	COTTER PIN, 3/16" X 2"
10	6T0836	2	CUP, CASTER WHEEL
11	22073	1	HEX NUT, 1NF (SLOTTED JAM NUT)
12	22071	5	HUB STUD
13	22066-1	1	HUB CASTER (REAR ROTARY)

ROTARY MOTOR

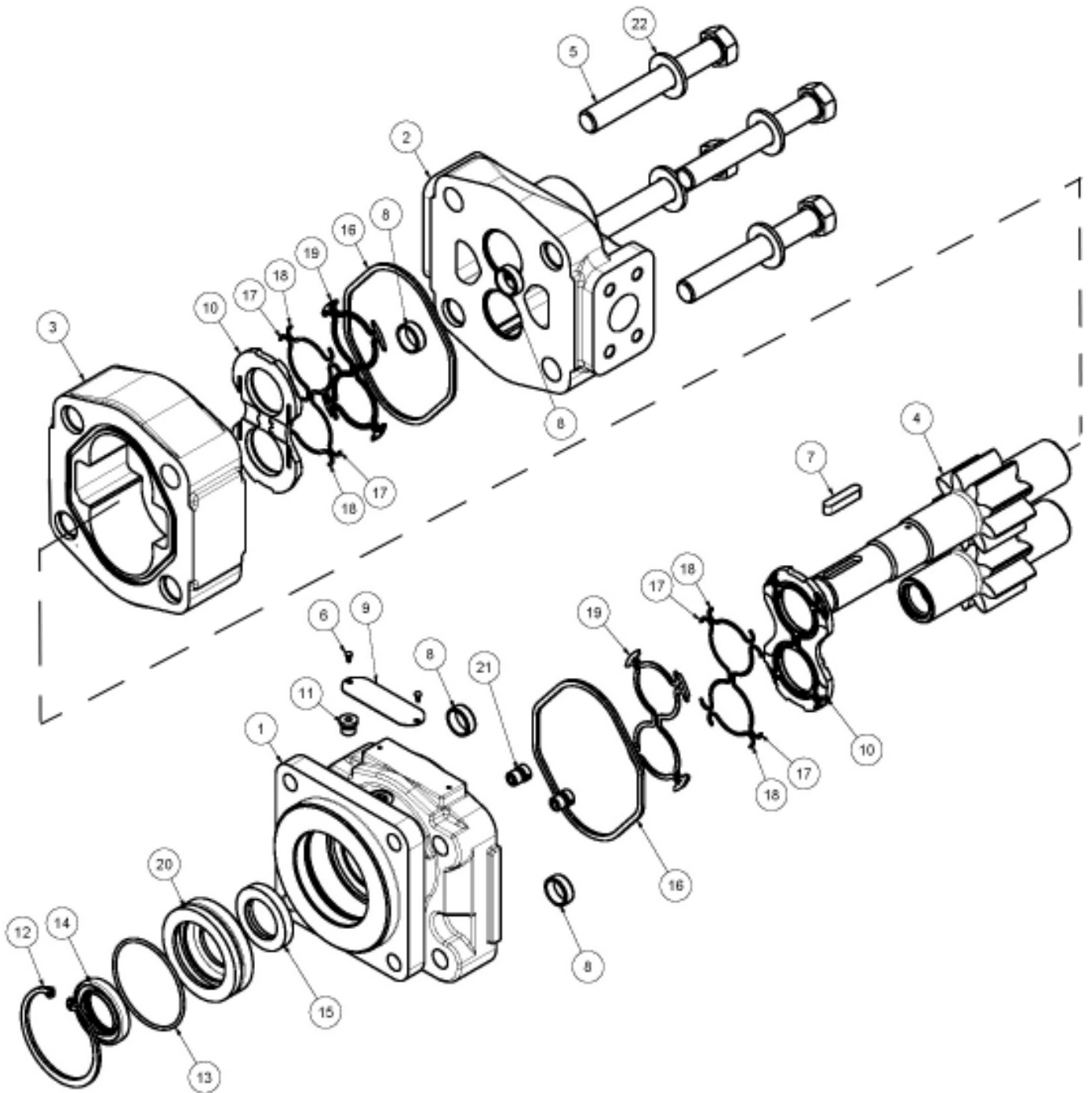

ROTARY MOTOR

60" ROTARY MOTOR

ITEM	PART NO.	QTY.	DESCRIPTION
*	06504011	AVAIL	MOTOR
	06504103	1	SEAL KIT
1	22790	1	HOUSING, SEC
2	06504088	1	HOUSING, PEC
3	06504062	1	HOUSING, GEAR
4	06504090	1	SET, GEAR SHAFT
5	06504104	4	CAP SCREW
6	06504078	2	SCREW, DRIVE
7	06504092	1	KEY
8	06504093	4	PIN, DOWEL
9	06504094	1	NAME PLATE
10	06504095	2	THRPL
11	02961940	1	PLUG, ODT
12	02962200	1	RING, SNAP
13	06504096	1	O RING
14	6T5101	1	SEAL, LIP
15	06504097	1	SEAL, LIP
16	22797	2	SEAL, SQ-R
17	06504098	4	SEAL, SIDE CHAN
18	06504099	4	SEAL, END CHAN
19	06504100	2	SEAL, BK-UP
20	06504101	1	RTNR, SEAL
21	6T5809	2	CHECK ASS'Y
22	06504102	4	WASHER

72" ROTARY MOTOR

ITEM	PART NO.	QTY.	DESCRIPTION
	06504018		MOTOR
	06504103	1	SEAL KIT
1	22790	1	HOUSING, SEC
2	06504088	1	HOUSING, SEC
3	06504062	1	HOUSING, GEAR
4	06504105	1	SET, GEAR SHAFT
5	06504106	4	CAP SCREW
6	06504078	2	SCREW, DRIVE
7	06504092	1	KEY
8	06504093	4	PIN, DOWEL
9	06504094	1	NAME PLATE
10	06504095	2	THRPL
11	02961940	1	PLUG, ODT
12	02962200	1	RING, SNAP
13	06504096	1	O RING
14	6T5101	1	SEAL, LIP
15	06504097	1	SEAL, LIP
16	22797	2	SEAL, SQ-R
17	06504098	4	SEAL, SIDE CHAN
18	06504099	4	SEAL, END CHAN
19	06504100	2	SEAL, BK-UP
20	06504101	1	RTNR, SEAL
21	6T5809	2	CHECK ASS'Y
22	06504102	4	WASHER

HYDRO PUMP & TSR MOTOR

FRONT PUMP

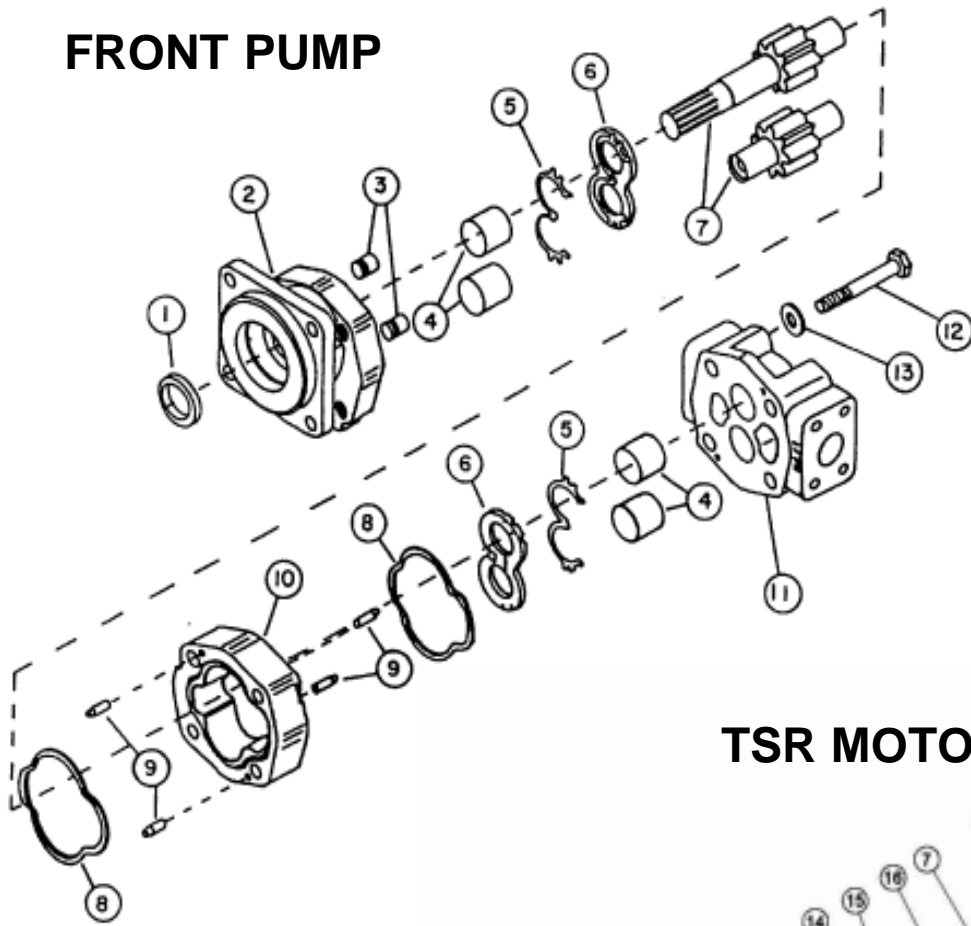

TSR MOTOR

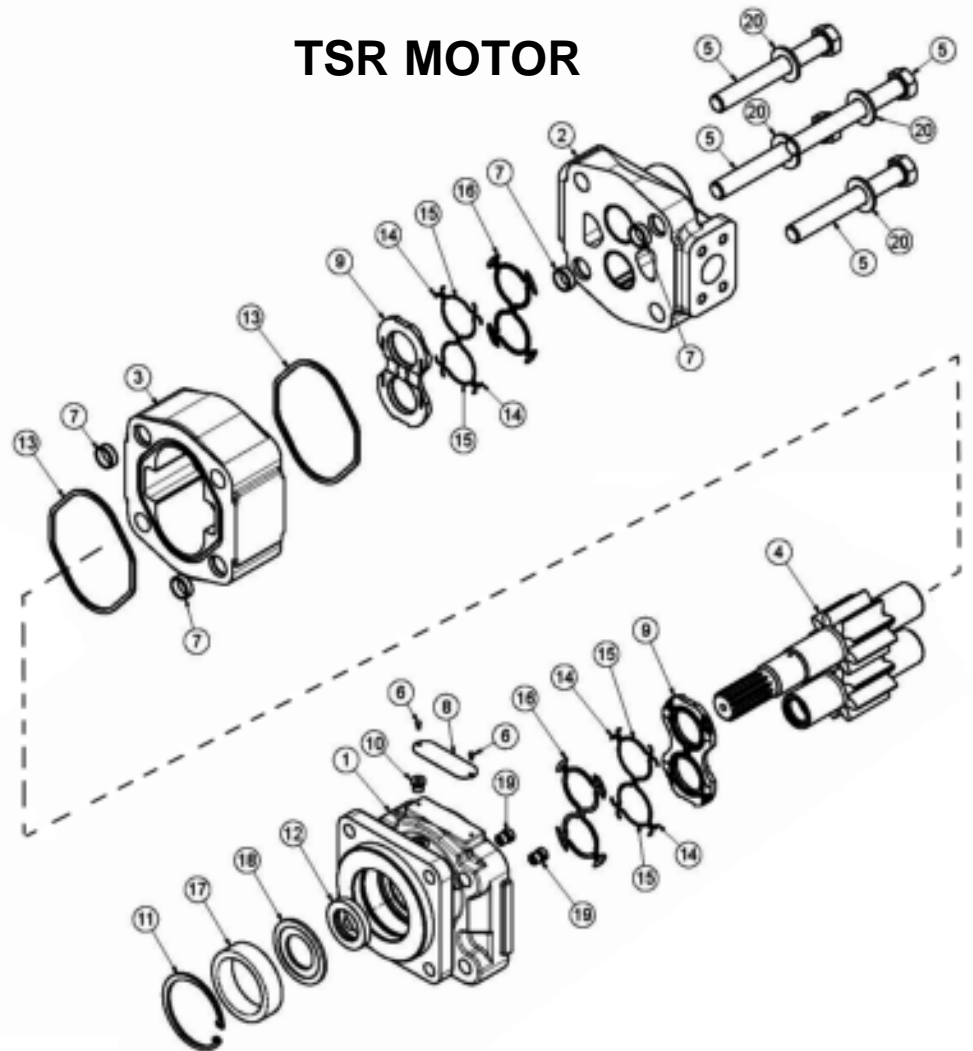

HYDRO PUMP & TSR MOTOR

FRONT HYDRAULIC PUMP

ITEM	PART NO.	QTY.	DESCRIPTION
	23152	AVAIL	PUMP ASSEMBLY 1 3/4" COMPLETE
1	22765	1	SEAL (INCLUDED IN SEAL KIT)
2	22766	1	SHAFT END COVER
3	22767	2	CHECK AND END COVER
4	22768	2	BUSHING
5	22769	2	CHANNEL SEAL (INCLUDED IN SEAL KIT)
6	22770	2	THRUST PLATE (INCLUDED IN SEAL KIT)
7	22771	SET	DRIVE SHAFT AND GEAR SET 1 3/4"
8	22772	2	GASKET SEAL (INCLUDED IN SEAL KIT)
9	22773	4	DOWEL PINS
10	22774	1	GEAR HOUSING 1 3/4"
11	22779	1	PORT END COVER
12	23824	4	STUDS
13	22781	SET	WASHER
	6T5322	AVAIL	SEAL APPLICATOR TOOL
	24150	AVAIL	SEAL KIT (INCLUDES 1, 5, 6 AND 8)

TSR MOTOR

ITEM	PART NO.	QTY.	DESCRIPTION
	06504016	AVAIL	MOTOR(M365-1 1/4SPLINE),SEALED
1	22790	1	HOUSING, SEC
2	06504088	1	HOUSING, PEC
3	06504111	1	HOUSING, GEAR
4	06504110	1	SET, GEAR SHAFT
5	06504104	4	CAP SCREW
6	06504078	2	SCREW, DRIVE
7	06504093	4	PIN, DOWEL
8	06504094	1	NAME PLATE
9	06504095	2	THRPL
10	02961940	1	PLUG, ODT (0.25)
11	6T5200	1	RING, SNAP
12	06504097	1	SEAL, LIP
13	22797	2	SEAL, SQ-R
14	06504098	4	SEAL, SIDE CHAN
15	06504099	4	SEAL, END CHAN
16	06504100	2	SEAL, BK-UP
17	06504112	1	SPACER
18	06504113	1	RTNR, SEAL
19	6T5809	2	CHECK ASS'Y
20	06504102	4	WASHER

SIDE COOLER

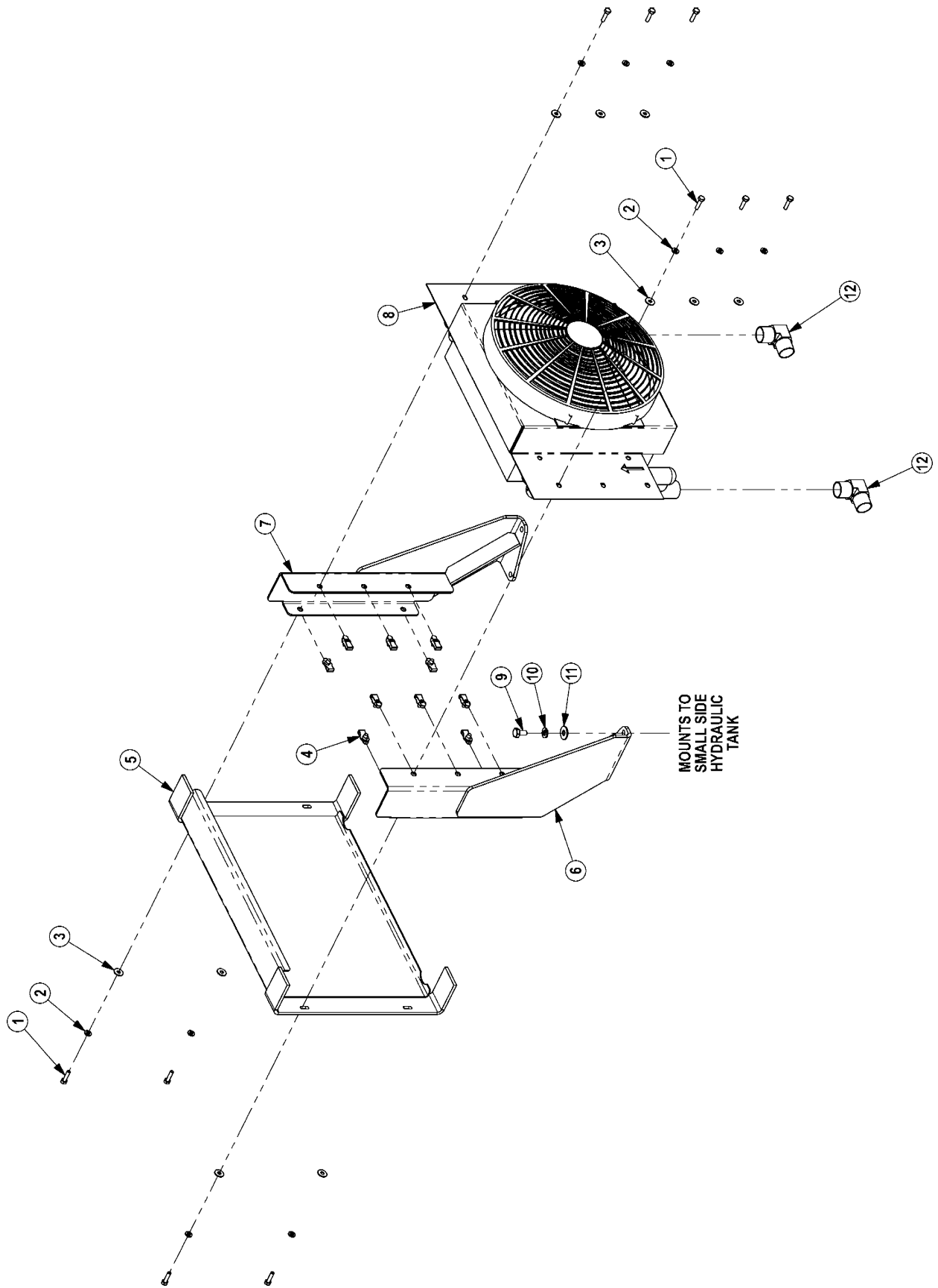

SIDE COOLER

ITEM	PART NO.	QTY.	DESCRIPTION
1	21530	10	CAPSCREW,1/4 X1 NC
2	21986	10	LOCKWASHER,1/4
3	22014	10	FLATWASHER,1/4
4	35176	10	1/4 U-NUT
5	06370015	1	SCREEN,COOLER,FRNT
6	06380006	1	MNT,COOLER,BUMPER TANK,RH
7	06380007	1	MNT,COOLER,BUMPER TANK,LH
8	06510026	1	COOLER,FRONT MNT
9	21629	4	CAPSCREW,3/8 X 3/4 NC
10	21988	4	LOCKWASHER,3/8
11	22016	4	FLATWASHER,3/8
12	34117	2	ELBOW,1MOR X 1MJ90,FORGED

2SP HUSCO - POWER BEYOND (30801)

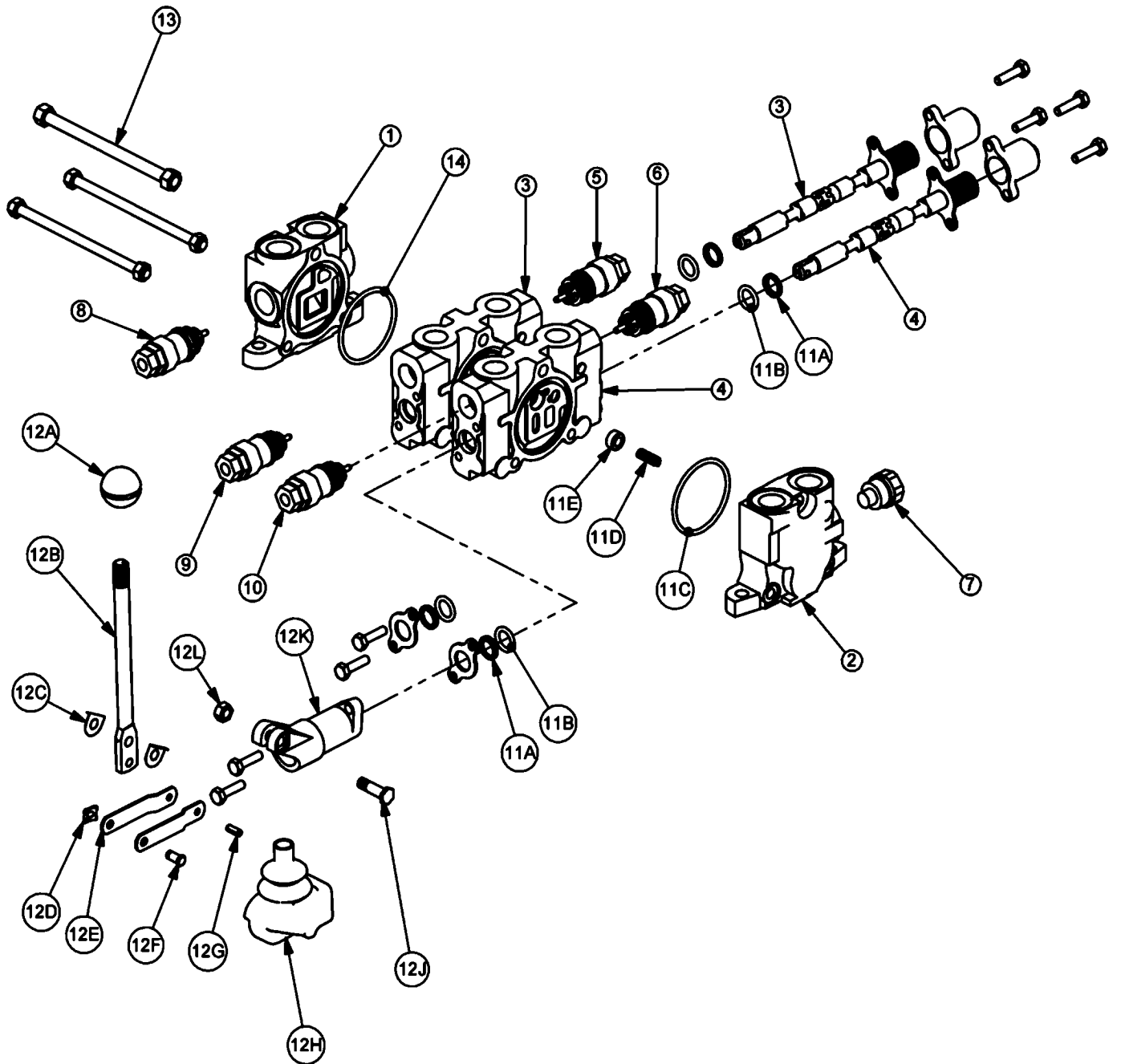

2SP HUSCO - POWER BEYOND (30801)

ITEM	PART NO.	QTY	DESCRIPTION
1	TB1017S	1	INLET END COVER
2	TB1702	1	END COVER, POWER BEYOND
3	TB1017P	1	VALVE SECTION (SINGLE ACTING, SPRING DETENT)
4	06502091	1	VALVE SECTION (DOUBLE ACTING, CENTER SPRING) (NO AUX VALVE PORTS)
5	N/A	-	N/A
6	N/A	-	N/A
7	TB1017M	1	SHUT-OFF PLUG
8	TB1017E	1	RELIEF VALVE, 2250 PSI
9	TB1017M	1	SHUT-OFF PLUG
10	N/A	-	N/A
11	TB1017A	2	VALVE SEAL KIT (FOR ONE SECTION)
11A		2	WIPER
11B		2	O-RING SMALL
11C		1	O-RING LARGE
11D		1	SPRING
11E		1	PUCKET
12	TB1017L	2	LEVER KIT (FOR ONE SECTION)
12A		1	LEVER KNOB
12B		1	LEVER
12C		2	LEVER WASHER
12D		1	LEVER CLIP
12E		2	LINKAGE
12F		1	LEVER PIN
12G		1	ROLL PIN
12H		1	LEVER BOOT
12J		1	LEVER BOLT
12K		1	LEVER DUST COVER
12L		1	LEVER NUT
13	TB1017X	1	TIE ROD KIT
14	24214	1	O-RING, LARGE

2 SP HUSCO - LOAD SENSE (31320)

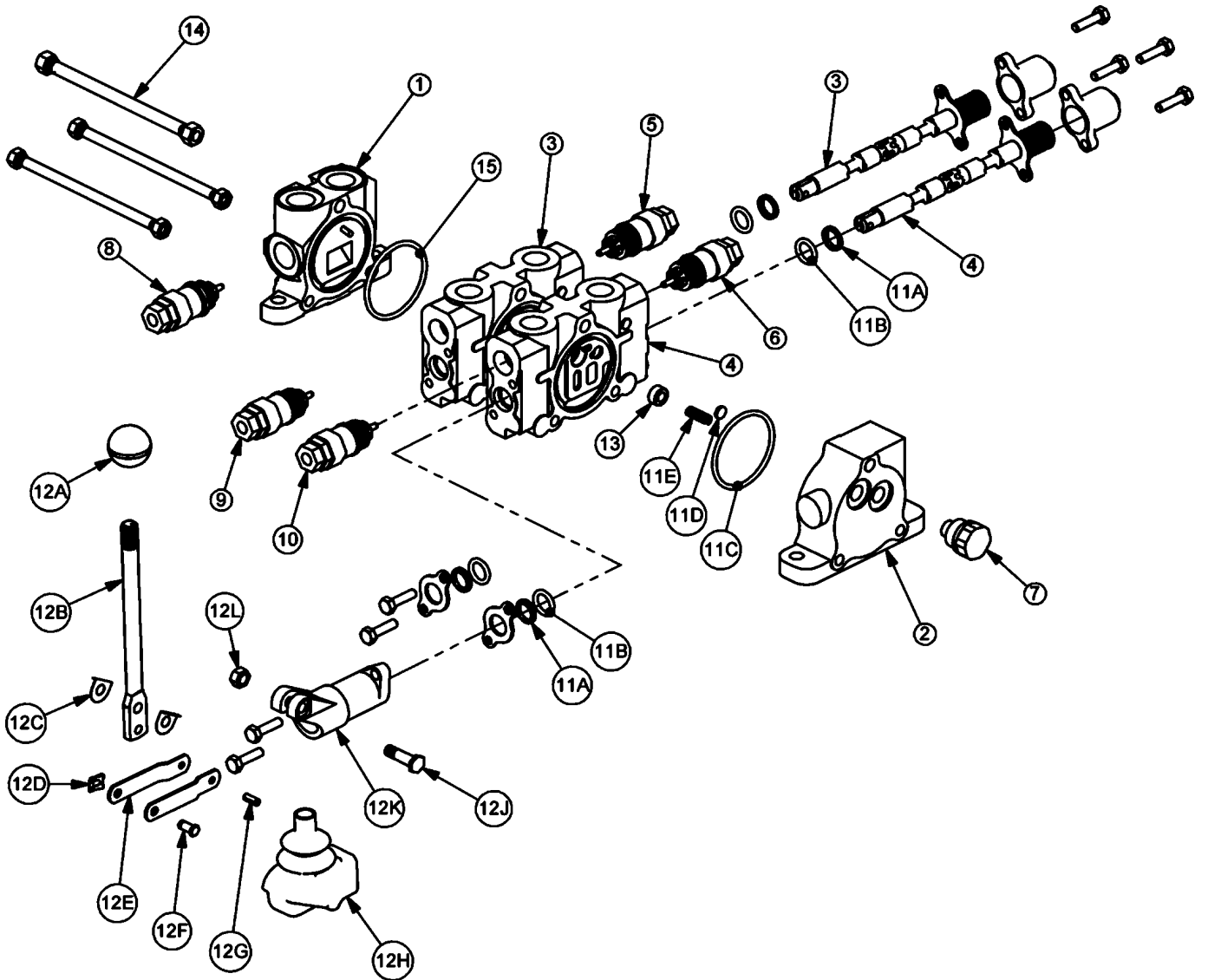

2 SP HUSCO - LOAD SENSE (31320)

ITEM	PART NO.	QTY	DESCRIPTION
1	31595	1	INLET END COVER
2	31594	1	END COVER, LOAD SENSE
3	31597	1	VALVE SECTION (DOUBLE ACTING, CENTER SPRING)
4	31597	1	VALVE SECTION (DOUBLE ACTING, CENTER SPRING)
5	06503067	1	RELIEF PLUG
6	06503067	1	RELIEF PLUG
7	N/A	-	N/A
8	6T4209	1	RELIEF PLUG
9	31862	1	RELIEF VALVE, 2175 PSI
10	31862	1	RELIEF VALVE, 2175 PSI
11	31593	2	VALVE SEAL KIT (FOR ONE SECTION)
11A		2	WIPER
11B		2	O-RING SMALL
11C		1	O-RING LARGE
11D		1	SHUTTLE DISC
11E		1	SPRING
12	TB1017L	2	LEVER KIT (FOR ONE SECTION)
12A		1	LEVER KNOB
12B		1	LEVER
12C		2	LEVER WASHER
12D		1	LEVER CLIP
12E		2	LINKAGE
12F		1	LEVER PIN
12G		1	ROLL PIN
12H		1	LEVER BOOT
12J		1	LEVER BOLT
12K		1	LEVER DUST COVER
12L		1	LEVER NUT
13	31603	2	COMPENSATOR
14	TB1017X	1	TIE ROD KIT
15	24214	1	O-RING, LARGE

2 SP HUSCO - LOAD SENSE (31321)

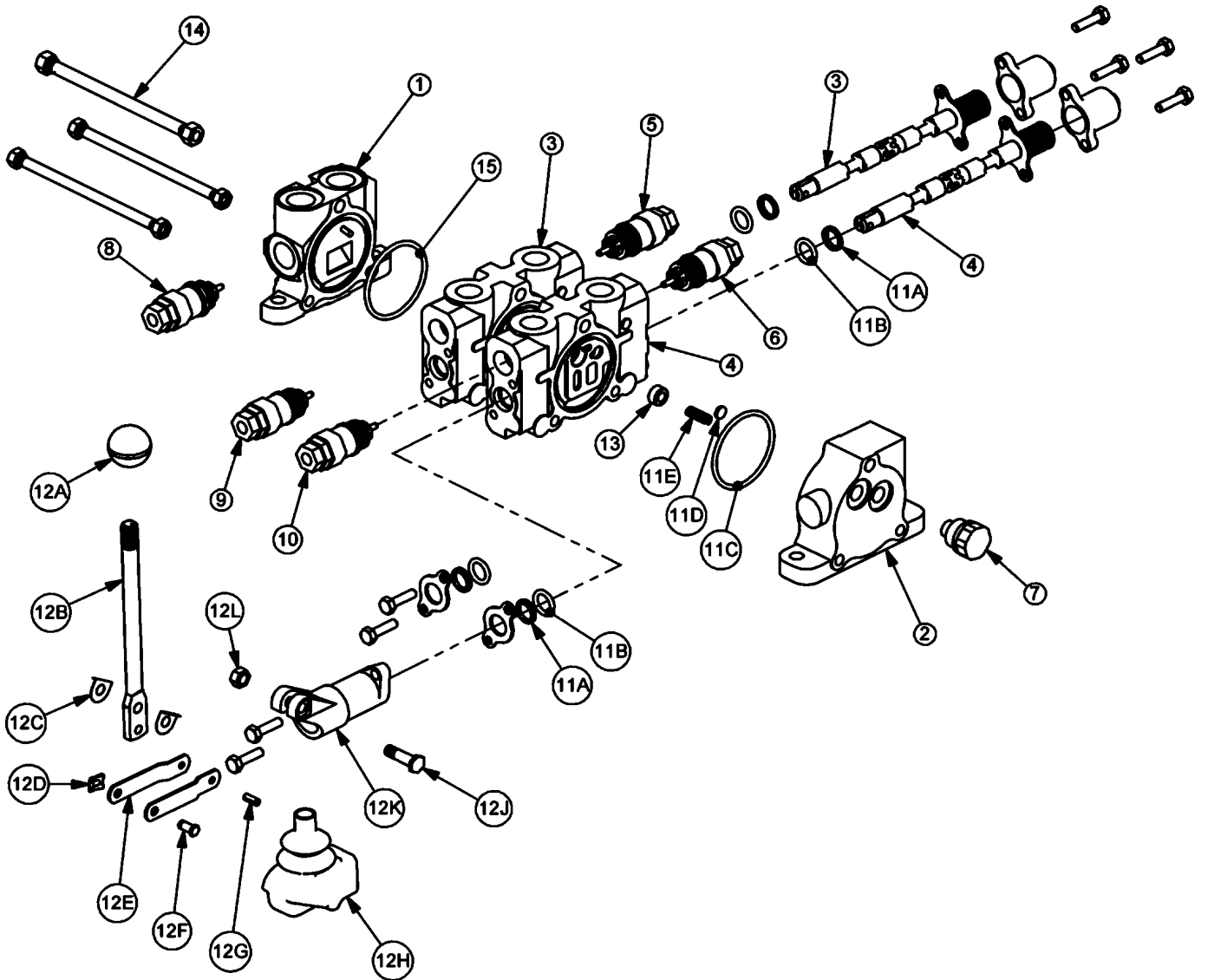

2 SP HUSCO - LOAD SENSE (31321)

ITEM	PART NO.	QTY	DESCRIPTION
1	31595	1	INLET END COVER
2	31594	1	END COVER, LOAD SENSE
3	31597	1	VALVE SECTION (DOUBLE ACTING, CENTER SPRING)
4	31597	1	VALVE SECTION (DOUBLE ACTING, CENTER SPRING)
5	06503067	1	RELIEF PLUG
6	31861	1	RELIEF VALVE, 360 PSI
7	N/A	-	N/A
8	6T4209	1	RELIEF PLUG
9	31862	1	RELIEF VALVE, 2175 PSI
10	31862	1	RELIEF VALVE, 2175 PSI
11	31593	2	VALVE SEAL KIT (FOR ONE SECTION)
11A		2	WIPER
11B		2	O-RING SMALL
11C		1	O-RING LARGE
11D		1	SHUTTLE DISC
11E		1	SPRING
12	TB1017L	2	LEVER KIT (FOR ONE SECTION)
12A		1	LEVER KNOB
12B		1	LEVER
12C		2	LEVER WASHER
12D		1	LEVER CLIP
12E		2	LINKAGE
12F		1	LEVER PIN
12G		1	ROLL PIN
12H		1	LEVER BOOT
12J		1	LEVER BOLT
12K		1	LEVER DUST COVER
12L		1	LEVER NUT
13	31603	2	COMPENSATOR
14	TB1017X	1	TIE ROD KIT
15	24214	1	O-RING, LARGE

2SP HUSCO - POWER BEYOND (31752)

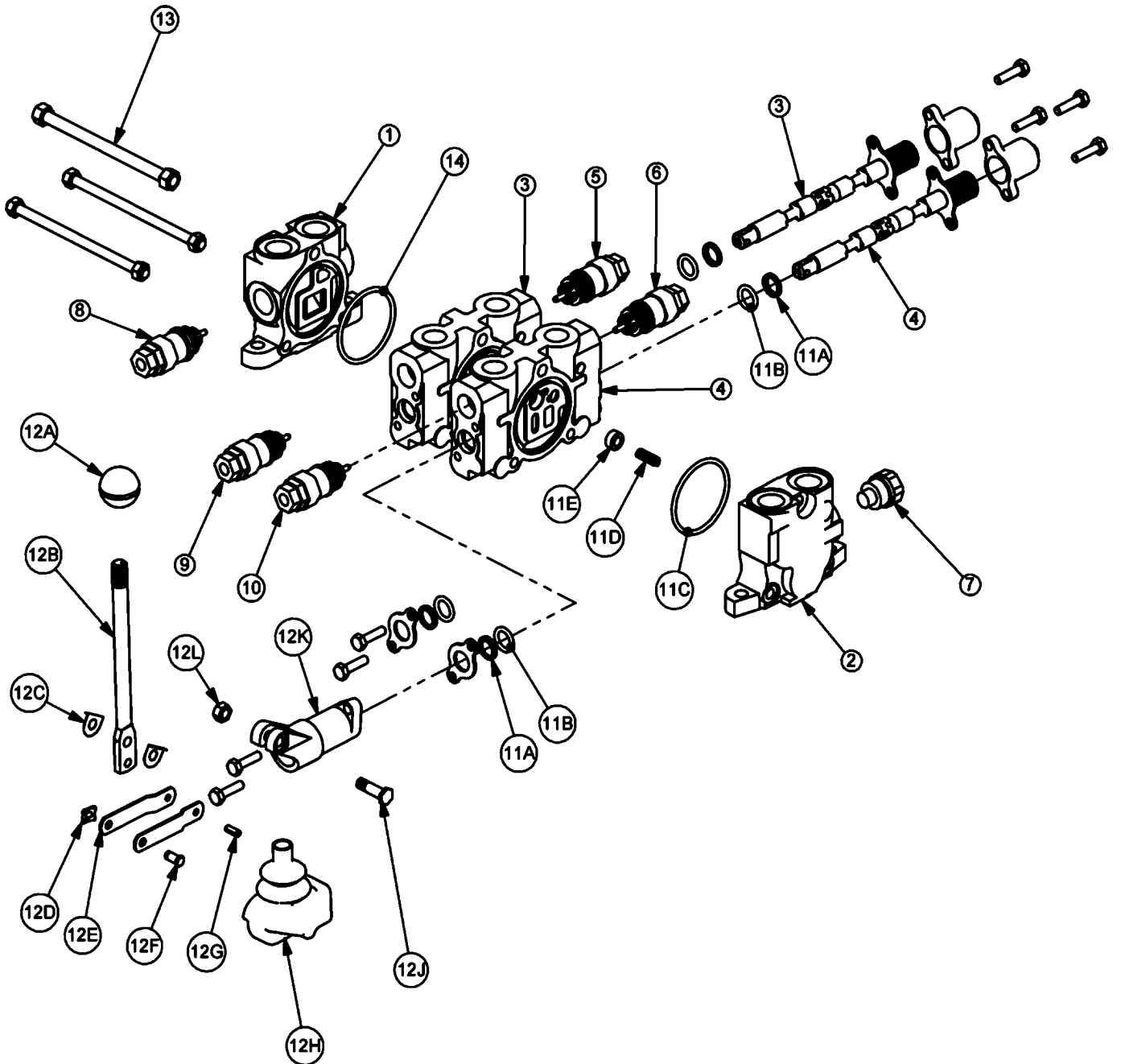

2SP HUSCO - POWER BEYOND (31752)

ITEM	PART NO.	QTY	DESCRIPTION
1	TB1017S	1	INLET END COVER
2	TB1702	1	END COVER, POWER BEYOND
3	TB1017P	1	VALVE SECTION (SINGLE ACTING, SPRING DETENT)
4	TB1017P	1	VALVE SECTION (SINGLE ACTING, SPRING DETENT)
5	N/A	-	N/A
6	N/A	-	N/A
7	TB1017M	1	SHUT-OFF PLUG
8	TB1017E	1	RELIEF VALVE, 2250 PSI
9	TB1017M	1	SHUT-OFF PLUG
10	TB1017M	1	TB1017M
11	TB1017A	2	VALVE SEAL KIT (FOR ONE SECTION)
11A		2	WIPER
11B		2	O-RING SMALL
11C		1	O-RING LARGE
11D		1	SPRING
11E		1	PUCKET
12	TB1017L	2	LEVER KIT (FOR ONE SECTION)
12A		1	LEVER KNOB
12B		1	LEVER
12C		2	LEVER WASHER
12D		1	LEVER CLIP
12E		2	LINKAGE
12F		1	LEVER PIN
12G		1	ROLL PIN
12H		1	LEVER BOOT
12J		1	LEVER BOLT
12K		1	LEVER DUST COVER
12L		1	LEVER NUT
13	TB1017X	1	TIE ROD KIT
14	24214	1	O-RING, LARGE

2SP HUSCO - LOAD SENSE (06502040)

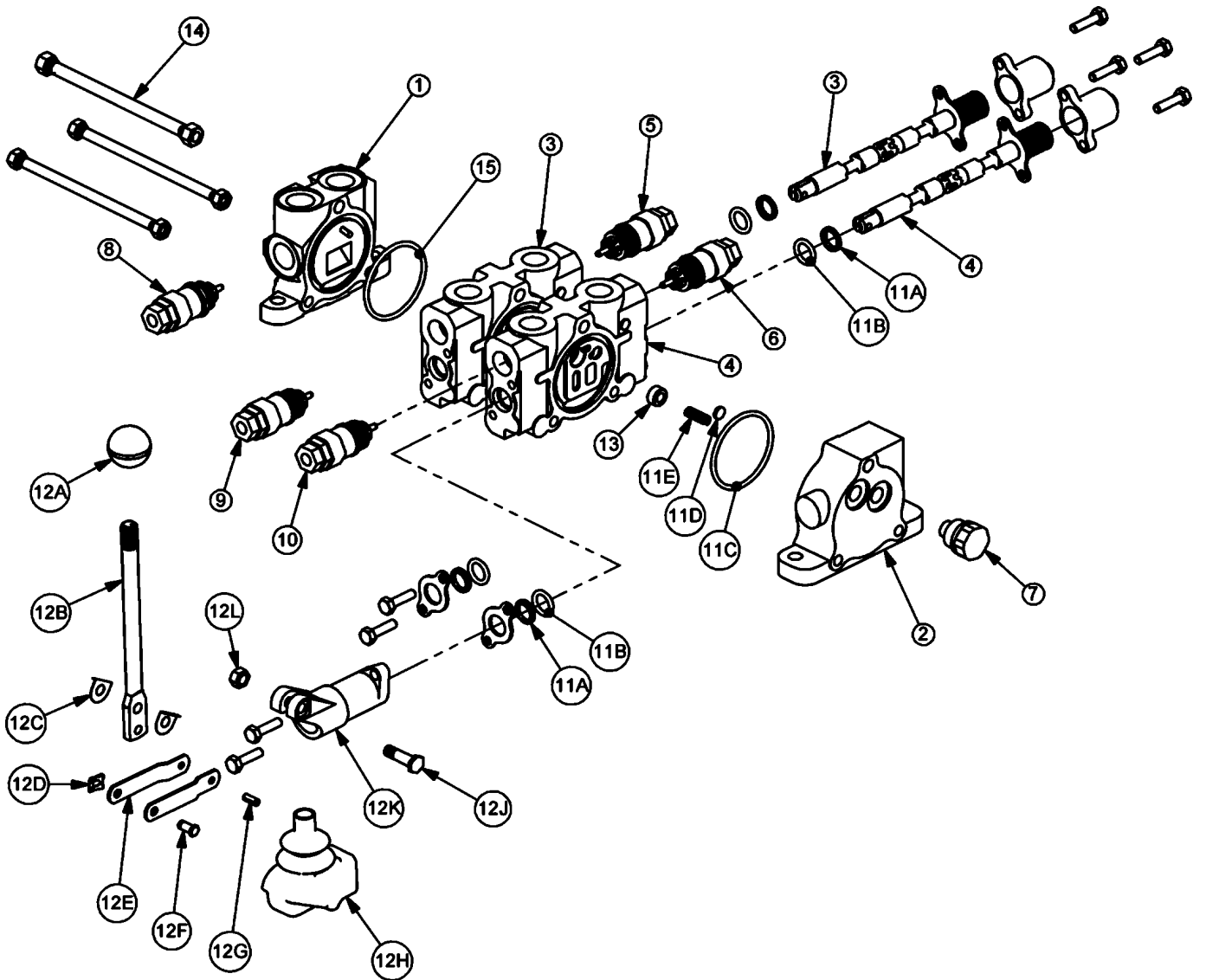

2SP HUSCO - LOAD SENSE (06502040)

ITEM	PART NO.	QTY	DESCRIPTION
1	31595	1	INLET END COVER
2	31594	1	END COVER, LOAD SENSE
3	31597	1	VALVE SECTION (DOUBLE ACTING, CENTER SPRING)
4	31597	1	VALVE SECTION (DOUBLE ACTING, CENTER SPRING) (REMOVE SHUTTLE DISC)
5	06503067	1	RELIEF PLUG
6	06503067	1	RELIEF PLUG
7	06503068	1	RELIEF PLUG
8	N/A	-	N/A
9	31862	1	RELIEF VALVE, 2175 PSI
10	31862	1	RELIEF VALVE, 2175 PSI
11	31593	2	VALVE SEAL KIT (FOR ONE SECTION)
11A		2	WIPER
11B		2	O-RING SMALL
11C		1	O-RING LARGE
11D		1	SHUTTLE DISC
11E		1	SPRING
12	TB1017L	2	LEVER KIT (FOR ONE SECTION)
12A		1	LEVER KNOB
12B		1	LEVER
12C		2	LEVER WASHER
12D		1	LEVER CLIP
12E		2	LINKAGE
12F		1	LEVER PIN
12G		1	ROLL PIN
12H		1	LEVER BOOT
12J		1	LEVER BOLT
12K		1	LEVER DUST COVER
12L		1	LEVER NUT
13	31603	2	COMPENSATOR
14	TB1017X	1	TIE ROD KIT
15	24214	1	O-RING, LARGE

2SP HUSCO - LOAD SENSE (06502042)

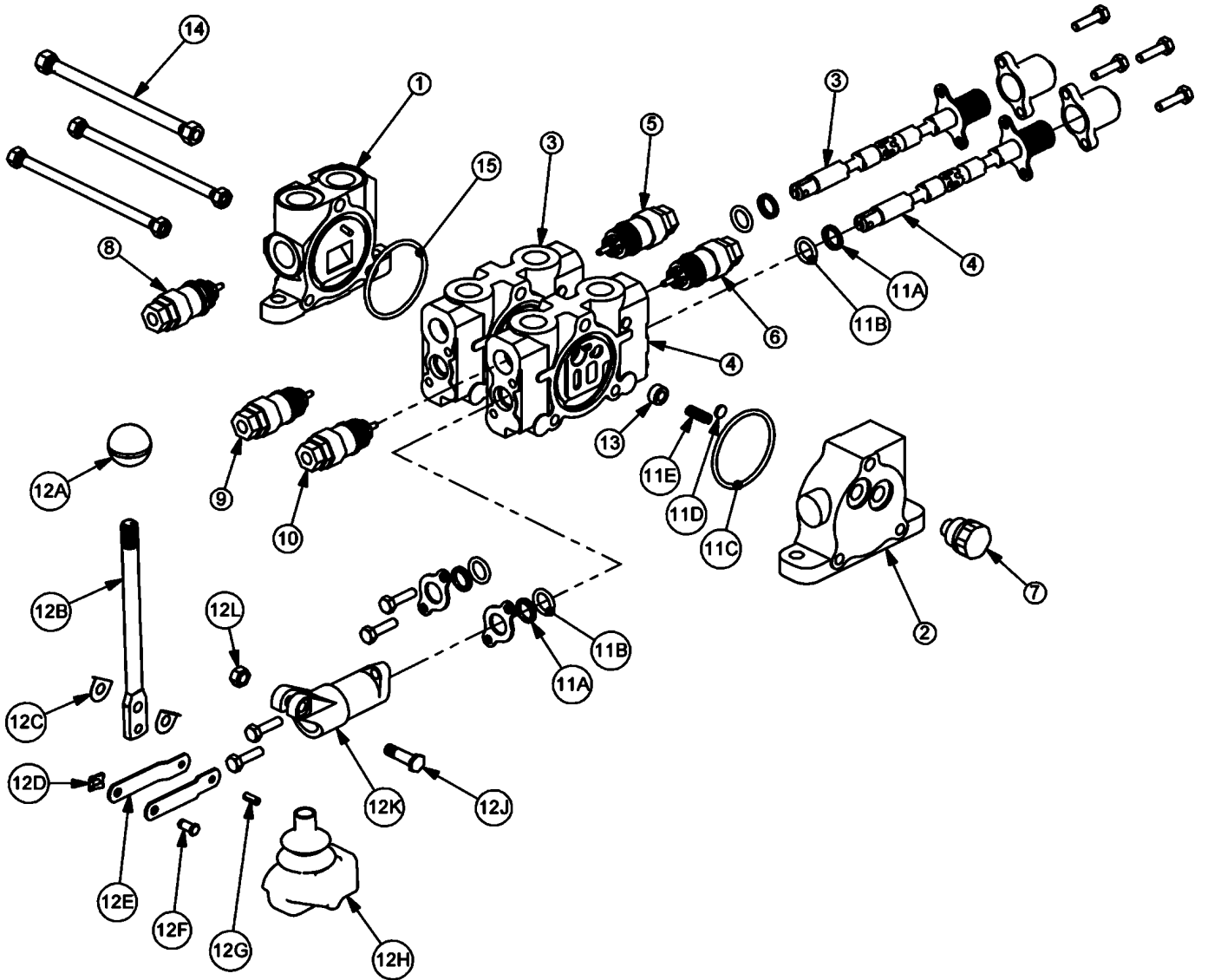

2SP HUSCO - LOAD SENSE (06502042)

ITEM	PART NO.	QTY	DESCRIPTION
1	31595	1	INLET END COVER
2	31594	1	END COVER, LOAD SENSE
3	31600	1	VALVE SECTION (DOUBLE ACTING, DETENT FLOAT)
4	31600	1	VALVE SECTION (DOUBLE ACTING, DETENT FLOAT) (REMOVE SHUTTLE DISC)
5	06503067	1	RELIEF PLUG
6	31861	1	RELIEF VALVE 360 PSI
7	06503068	1	RELIEF PLUG
8	6T4209	1	RELIEF PLUG
9	31862	1	RELIEF VALVE, 2175 PSI
10	31862	1	RELIEF VALVE, 2175 PSI
11	31593	2	VALVE SEAL KIT (FOR ONE SECTION)
11A		2	WIPER
11B		2	O-RING SMALL
11C		1	O-RING LARGE
11D		1	SHUTTLE DISC
11E		1	SPRING
12	TB1017L	2	LEVER KIT (FOR ONE SECTION)
12A		1	LEVER KNOB
12B		1	LEVER
12C		2	LEVER WASHER
12D		1	LEVER CLIP
12E		2	LINKAGE
12F		1	LEVER PIN
12G		1	ROLL PIN
12H		1	LEVER BOOT
12J		1	LEVER BOLT
12K		1	LEVER DUST COVER
12L		1	LEVER NUT
13	31603	2	COMPENSATOR
14	TB1017X	1	TIE ROD KIT
15	24214	1	O-RING, LARGE

SOLENOID VALVE ASSEMBLY

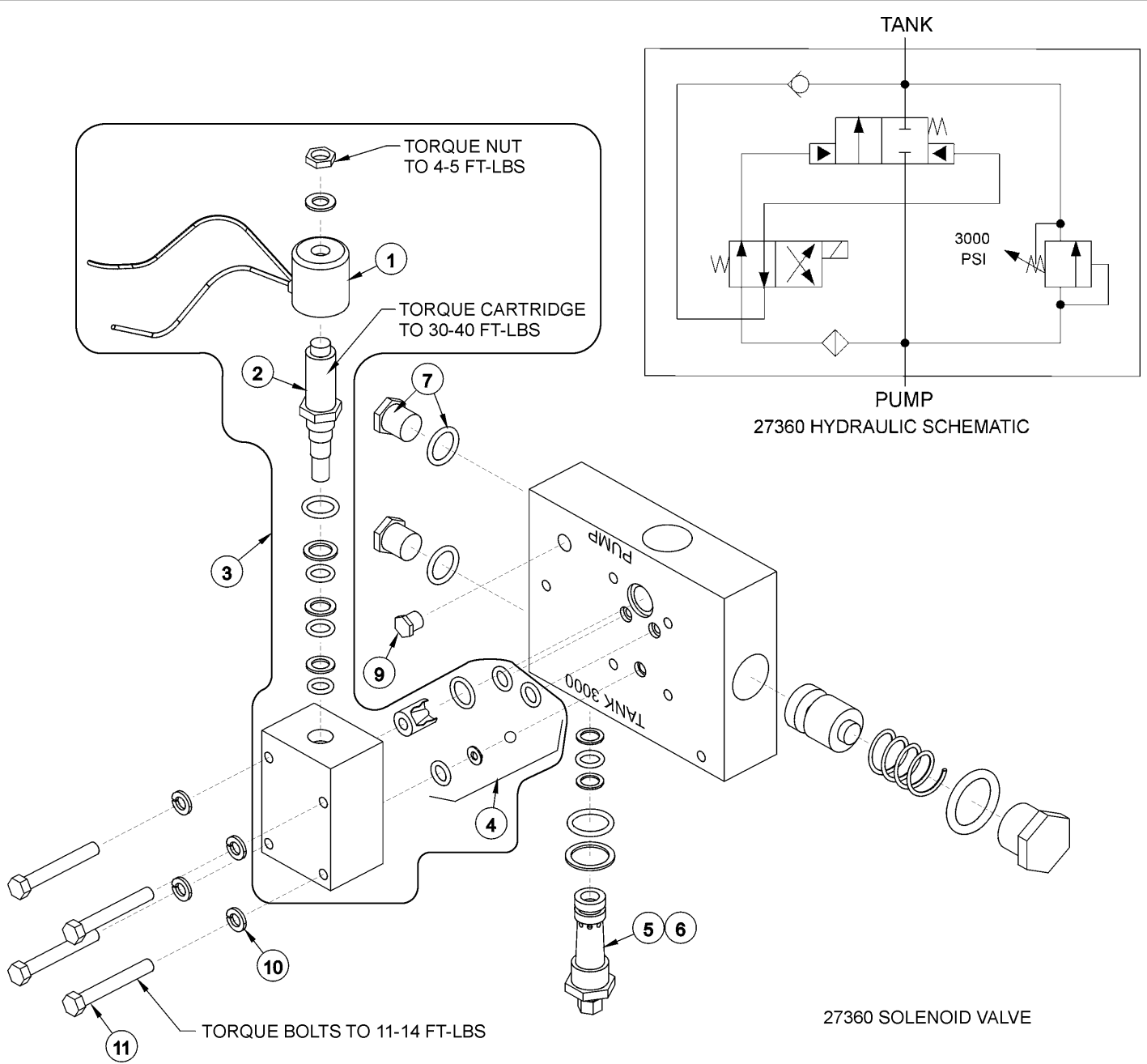

ITEM	PART NO.	QTY.	DESCRIPTION
	06502007	AVAIL	VALVE ASY HIGH PRESSURE
	06502008	AVAIL	VALVE ASY LOW PRESSURE
1	34689	1	SOLENOID COIL
2	06505026	1	SOLENOID
3	06502009	1	SOLENOID VALVE KIT
4	6T3911	1	SOLENOID SEAL KIT
5	6T3908	1	RELIEF PILOT 2150 PSI LOW PRESSURE
6	6T3910	1	RELIEF PILOT 3400 PSI HIGH PRESSURE
7	6T4209	2	PLUG W/ O - RING
9	TF1228	1	PLUG 1/4" NPT HOLLOW HEX
10	21987	4	LOCKWASHER 5/16"
11	21586	4	CAPSCREW 5/16" X 2 1/2"

SOLENOID BRAKE VALVE ASSEMBLY

NOTE:

CAUTION - TORQUE COIL NUT TO 5 Ft. Lbs. MAXIMUM. DO NOT OVER TORQUE NUT, DAMAGE TO CARTRIDGE OR COIL WILL OCCUR.

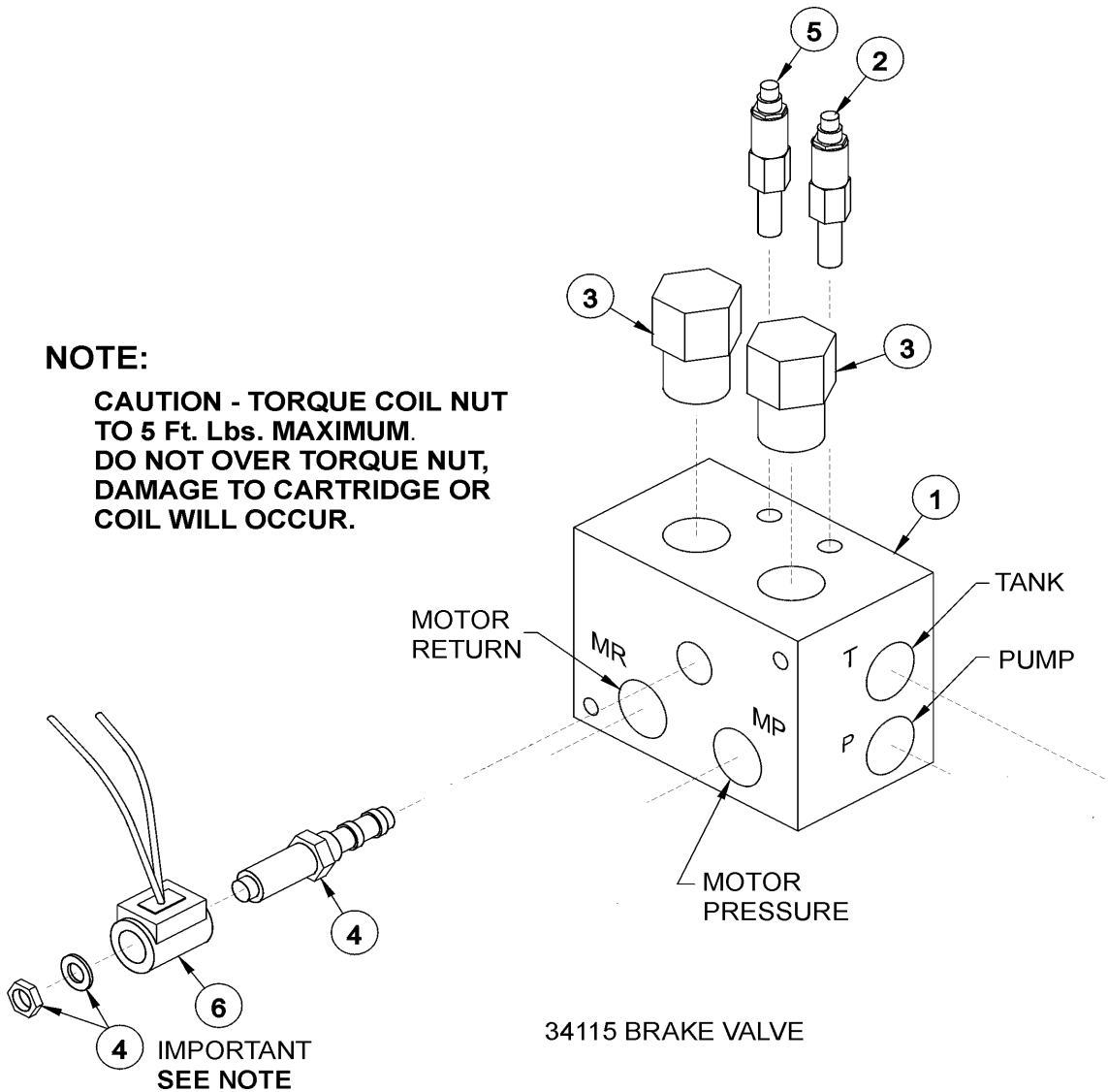

ITEM	PARTNO.	QTY.	DESCRIPTION
*	34115	AVAIL	SOLENOID BRAKE VALVE ASSEMBLY - HIGH PRESSURE
1	34092	1	BRAKE VALVE, BLANK
2	34095	1	RELIEF VALVE, 3000 PSI
3	34094	2	LOGICELEMENT
4	34093	1	CARTRIDGE, 2 POSITION, 3 WAY (WITH NUT & WASHER)
5	34091	1	RELIEF VALVE, 2600 PSI
6	34689	1	COIL, 12 VDC, BRAKE VALVE
**	34096	2	RELIEF SEAL KIT
**	34097	1	SOLENOID SEAL KIT
**	34098	2	ELEMENT SEAL KIT

BRAKE VALVE ASSEMBLY W/ METRI PAK

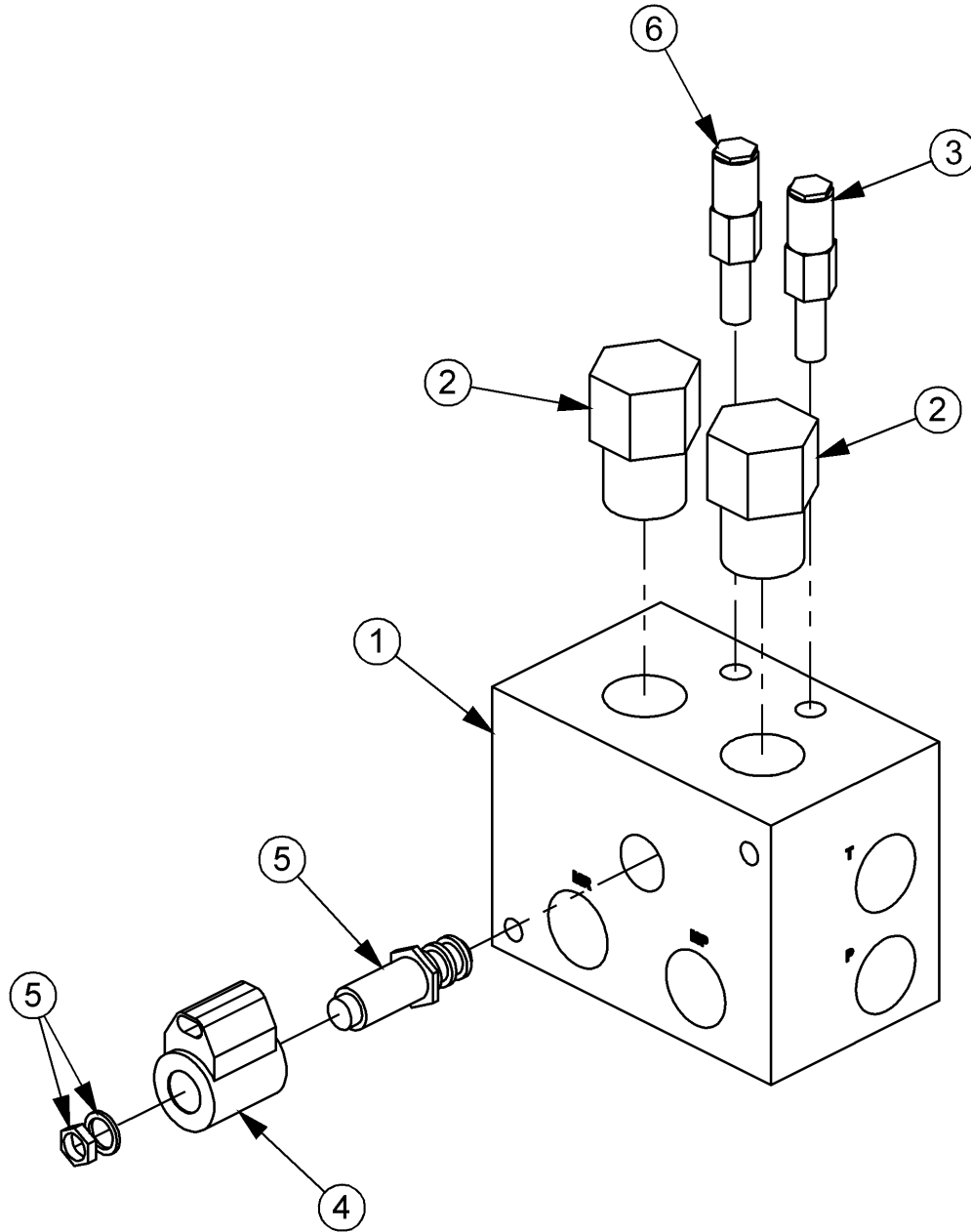

ITEM	PARTNO.	QTY.	DESCRIPTION
1	34092	1	BRAKE VALVE, BLANK
2	34094	2	LOGIC ELEMENT
3	34095	1	RELIEF VALVE, 3000 PSI
4	06510095	1	METRI PAK COIL
5	34093	1	CARTRIDGE, 2 POSITION, 3 WAY (WITH NUT & WASHER)
6	34091	1	RELIEF VALVE, 2600 PSI

SOLENOID BRAKE VALVE HYDRAULIC SCHEMATIC

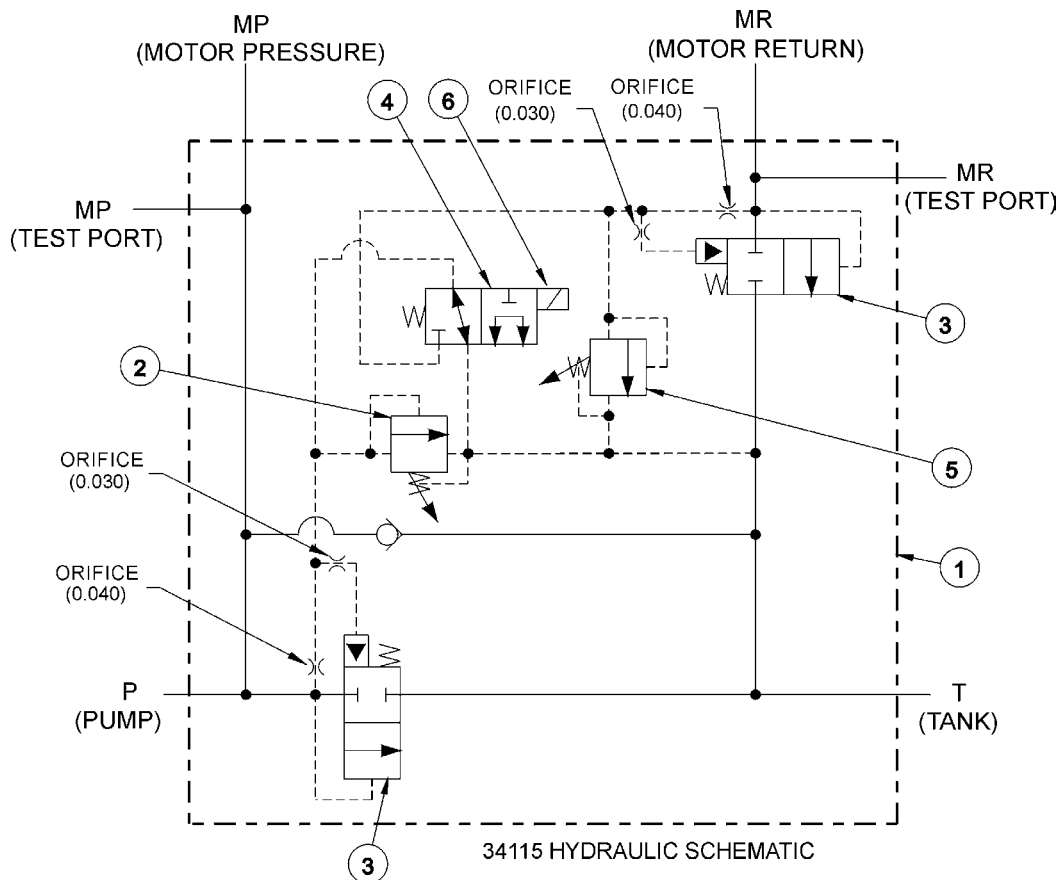

BRAKE VALVE TROUBLESHOOTING

FAILURE MODE:

- MOWER WILL NOT START - system pressure is low (engine not lugging).
- MOWER WILL NOT START - system pressure is high (engine lugging). "MR" port will be high pressure.
- MOWER WILL NOT ROTATE AT FULL SPEED - limited power.
- MOWER BLADE WILL NOT STOP - blade will not stop in proper time.

CHECK STEPS

- 1 thru 6
- 7
- 3 thru 5
- 7 thru 9

CORRECTIVE STEPS:

1. Check for voltage at solenoid (item 6), voltage must be between 10.2 volts and 13.8 volts.
2. Remove, inspect solenoid and cartridge (items 4, 6) for wear or contamination.
3. Remove, inspect logic elements near "P" port (item 3) for wear or contamination.
4. Remove, inspect 3000 psi relief valve (item 2) for wear or contamination.
5. Remove and inspect orifices near "P" port for contamination.
6. Remove "P" port hose and fitting, visually inspect for contamination, check ball for movement.
7. Remove and inspect orifices near "MR" port for contamination.
8. Remove, inspect 2600 psi relief valve (item 5) for wear of contamination.
9. Remove, inspect logic element near "MR" port (item 3) for wear or contamination.

TRAVEL LOCK LIFT BEAM

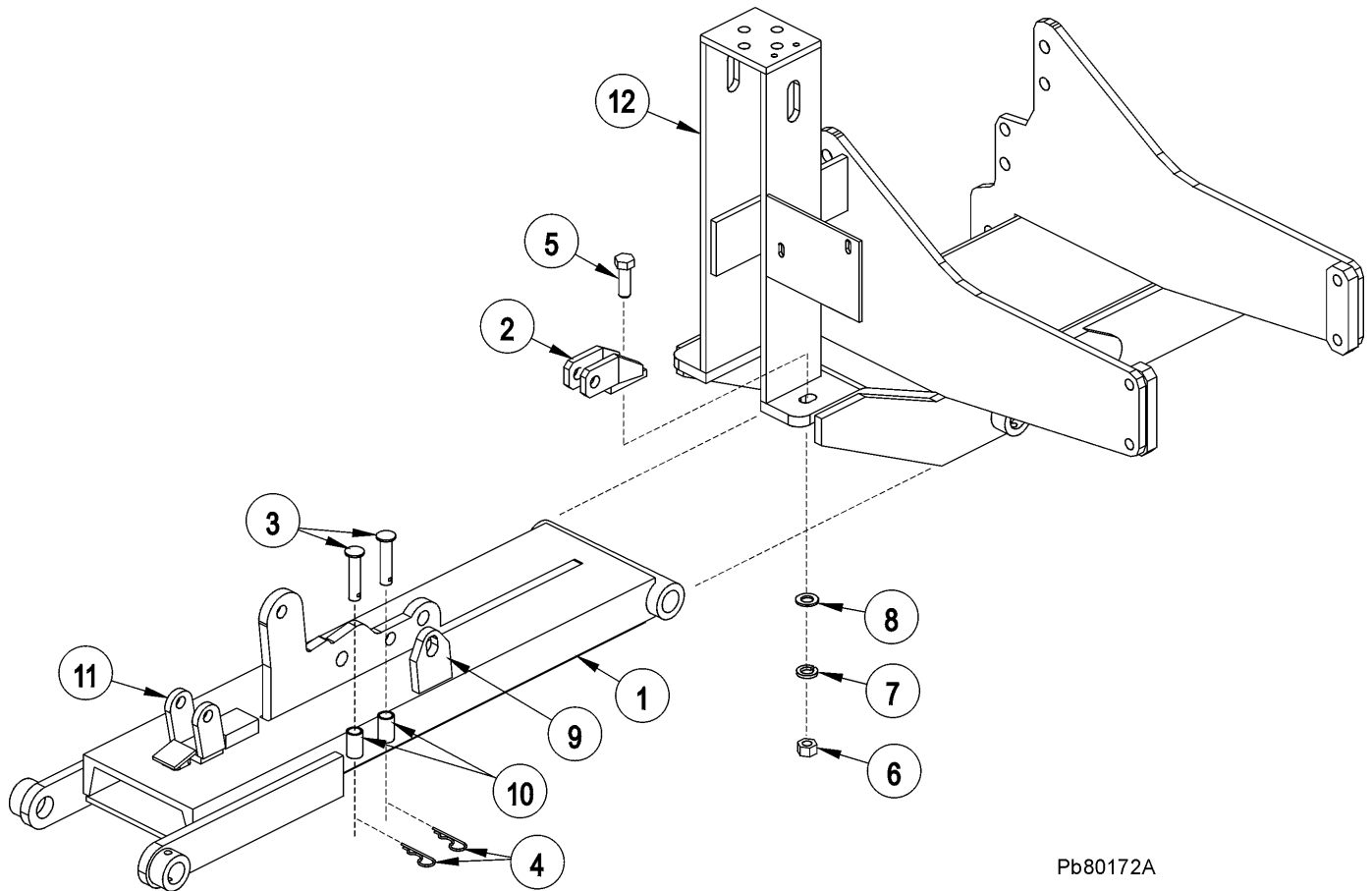

Pb80172A

ITEM	PART NO.	QTY.	DESCRIPTION
1	6T0105	1	DRAFT BEAM (STD WITH TRAVEL LOCKS)
2	6T0106	1	TRAVEL LOCK BRACKET
3	6T0107	2	TRAVEL LOCK PINS 3/4" X 3 1/4"
4	6T3020	2	R - CLIP 5/32"
5	21833	1	CAPSCREW 3/4" X 2 1/4"
6	21825	1	HEX NUT 3/4"
7	21993	1	LOCK WASHER 3/4"
8	22021	1	FLAT WASHER 3/4"
9	22600	1	TRAVEL LOCK EAR
10	22604	2	PINHOLDER
11	22601C	1	TRAVEL LOCK ASY
12	*	REF.	MAIN FRAME REFER TO PARTS SECTION

SIDE MOWER TRAVEL LOCK (COMBO)

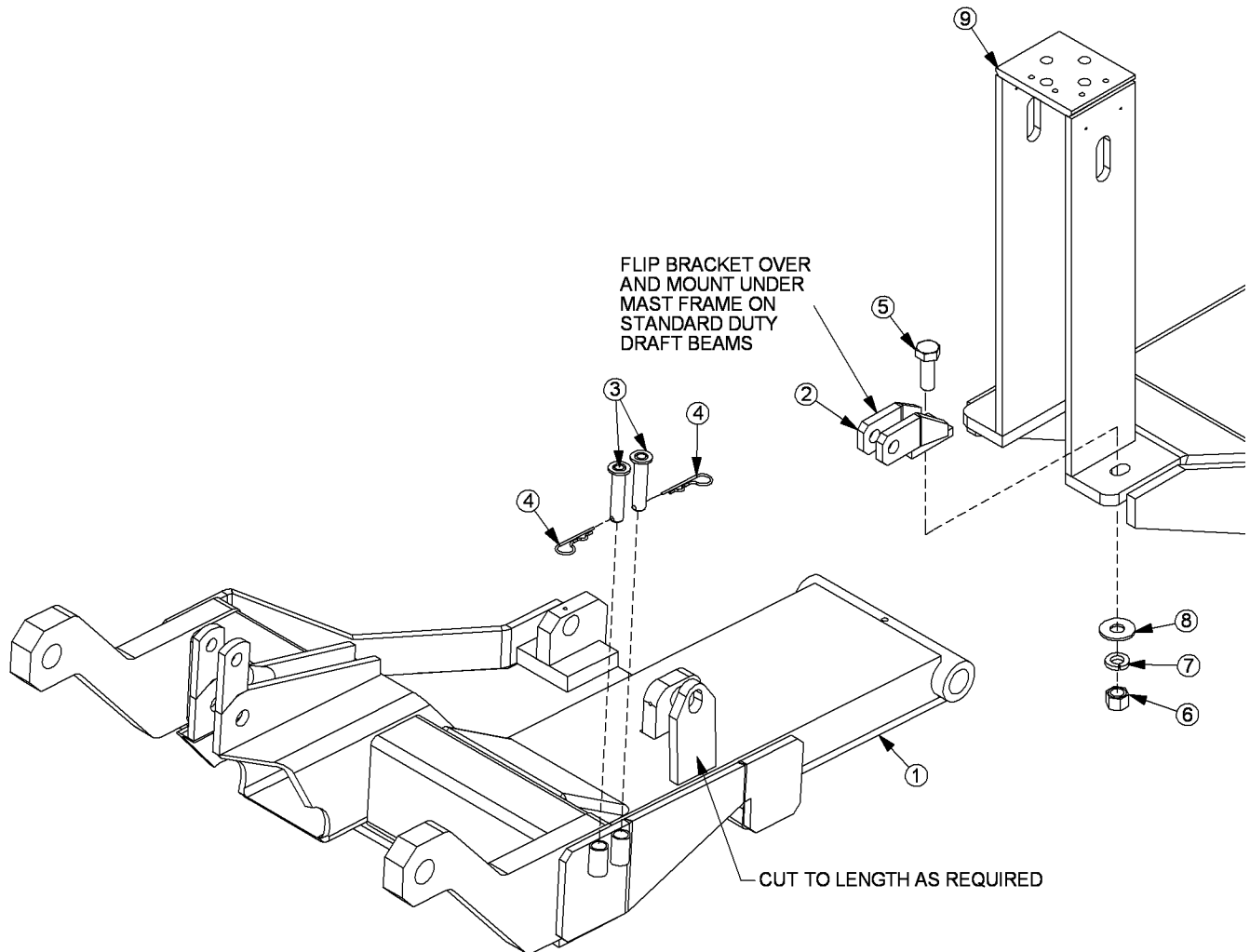

06200381

ITEM	PART NO.	QTY.	DESCRIPTION
1	REF	*	COMBO DRAFT BEAM- REFER TO DRAFT BEAM PARTS
2	6T0106	1	TRAVEL LOCK BRACKET
3	6T0107	2	TRAVEL LOCK PIN (3/4" x 3-1/4" CAPPED)
4	6T3020	2	R-CLIP, 5/32"
5	21833	1	CAPSCREW, 3/4" x 2-1/4" NC
6	21825	1	HEX NUT, 3/4" NC
7	21993	1	LOCKWASHER, 3/4"
8	22021	1	FLAT WASHER, 3/4"
9	REF.	*	MAIN FRAME - REFER TO MAIN FRAME PARTS

SWITCHBOX SERVICE PARTS

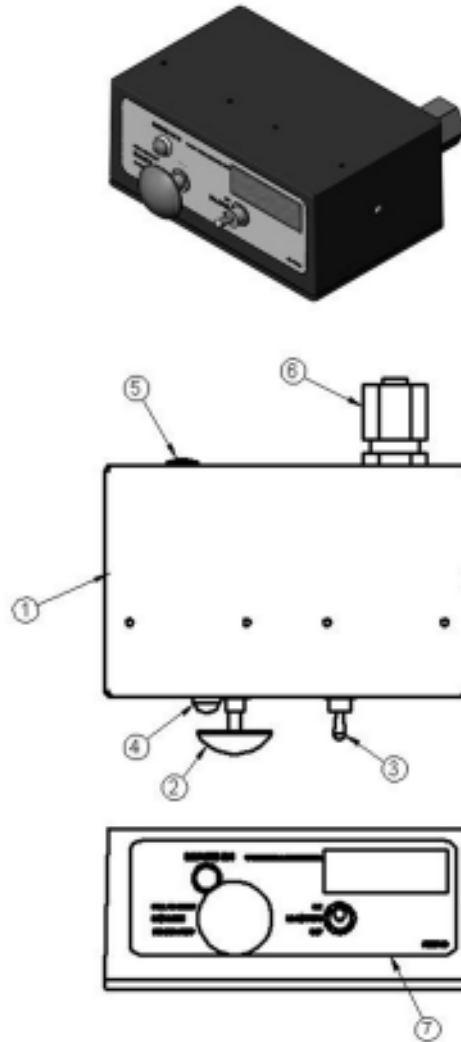

ITEM	P/N	QTY.	DESCRIPTION
1	06514013	1	SWBX,ALUM,BLK,06510102
2	35226	1	SWITCH,MOWER,COLEHERSEE
3	33811	1	SWITCH,MASTER/DECK FLOAT
4	6T3923	1	INDICTATOR LIGHT,ON,RED
5	06514014	1	BREAKER,10A,SWBX
6	34540	1	STRAIN RELIEF,3/4,BLACK,NYLON
7	06550018	1	DECAL,SWTCHBX,TM/TSF,CG
8	35227	1	RELAY,DP,DT,12V,LY2F,35226

SWITCHBOX SCHEMATIC

06510102 SCHEMATIC COMMON GROUND SWITCH BOX SIDE MOWER

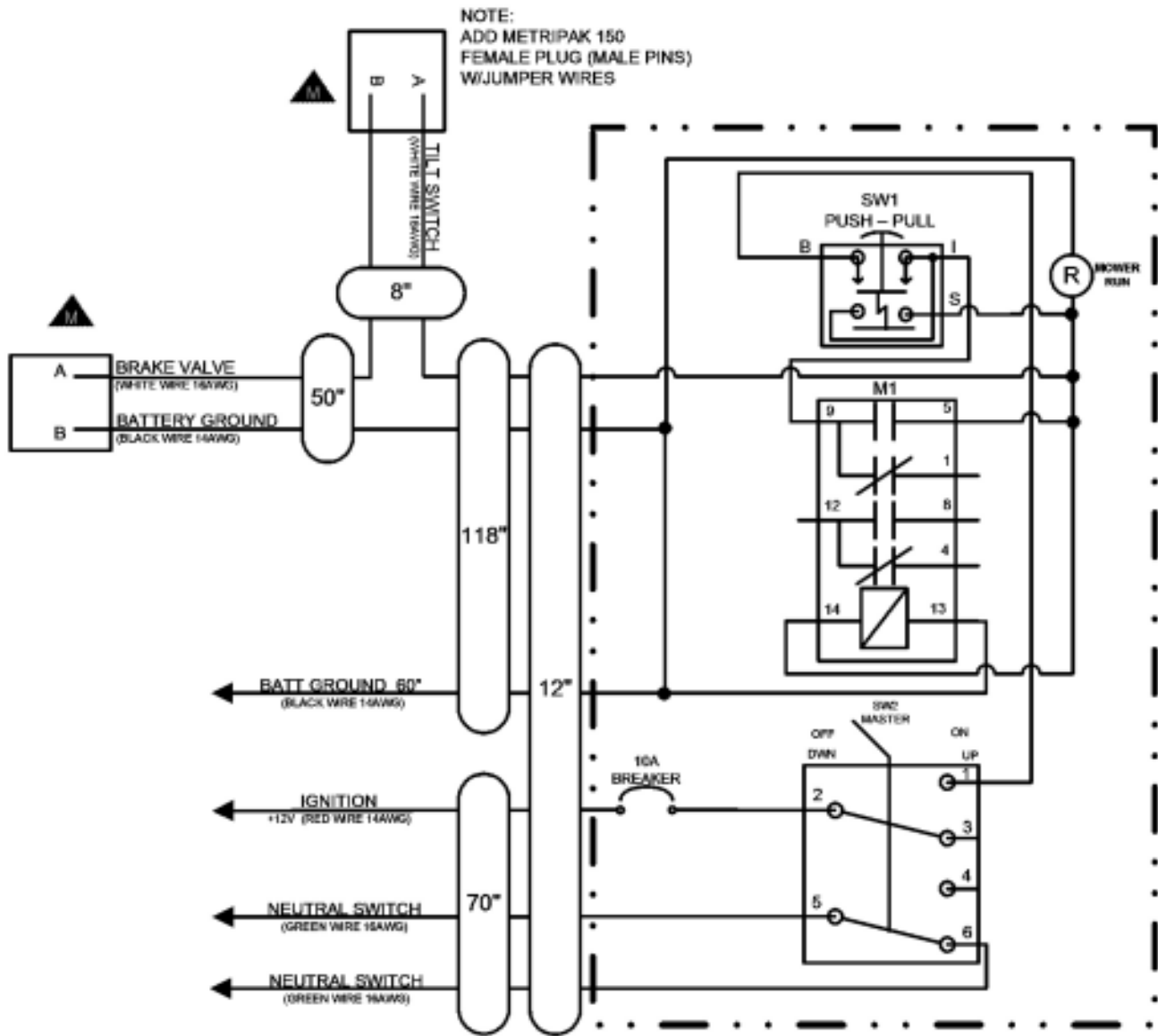

SEE DRAWING # 06515000 FOR A FULL DESCRIPTION OF ALL CONNECTORS

Empty rectangular box at the top of the page.

Large empty rectangular box occupying the majority of the page.

WARRANTY SECTION

WARRANTY INFORMATION

Tiger Corporation, 3301 N. Louise, Sioux Falls, South Dakota, warrants to the original Retail Customer, the new Tiger equipment is free of defects in material and workmanship. Any part of equipment that in Tiger's judgement, show evidence of such defects will be repaired or replaced without charge, provided that the failure of part(s) shall have occurred within twelve (12) months from the date of delivery of said equipment to the Retail Customer. Expendable components such as knives, oil, chain sprockets, skid shoes, knife mounting disks and the like are excluded but not limited to this warranty.

The Retail Customer must pay the transportation cost to and from the Tiger Dealer's service shop for warranty service. Warranty service will be performed by the Tiger Dealer from whom the equipment was purchased, during service shop regularly scheduled days and hours of operation.

All Tiger obligation under this warranty shall be terminated if the equipment is modified or altered in ways not approved in writing by Tiger, if repair parts other than genuine Tiger repair parts have been used, or if the equipment has been subject to misuse, neglect, accident, improper maintenance or improper operation.

Tiger Corporation reserves the right to make improvements in design or changes in specification at any time without incurring any obligation to owners of equipment previously sold.

No agent or person has authority to alter, add to or waive the above warranties which are agreed to be in the only warranties, representations or promises, expressed or implied, as to the quality or performance of the products covered and which do not include any implied warranty of merchantability or fitness. In no event will Tiger be liable for incidental or consequential damages or injuries, including, but not limited to, loss of profits, rental or substitute equipment or other commercial loss.

**THERE ARE NO WARRANTIES WHICH EXTEND
BEYOND THOSE EXPRESSED HEREIN.**

It is the Purchasers obligation to sign the warranty registration form **AFTER** he / she has Read and Understands the Operation and Safety Instructions stated within this manual.

ONE LAST WORD

This manual cannot possibly cover all of the potentially hazardous situations you will encounter. By being familiar with the safety rules, operating and maintenance instructions in this manual you can help prevent accidents. The objective of this manual is to help make you a better operator. Remember, **SAFETY IS YOU!**



1012

Your safety and the safety of those around you depends on **YOU**. Common sense should play a large role in the operation of this machine.

Since we at Tiger Corporation are constantly striving to improve our products, we reserve the right to change specifications or design at any time.

TO THE OWNER / OPERATOR / DEALER



To keep your implement running efficiently and safely, read your manual thoroughly and follow these directions and the Safety Messages in this manual and on the machine. The table of contents clearly identifies each section where you can easily find the information you need.

The Occupational Safety and Health Act (OSHA 1928.51 subpart C) makes the following minimum requirements for tractor operators.

OWNER REQUIREMENTS:

1. Provide a Roll-Over-Protective Structure that meets the requirements of this Standard; and
2. Provide Seatbelts that meet the requirements of this Standard and SAE J3C; and
3. Ensure that each employee uses such Seatbelt while the tractor is moving; and
4. Ensure that each employee tightens the Seatbelt sufficiently to confine the employee to the protected area provided by the ROPS.

OPERATOR REQUIREMENTS:

1. Securely fasten seatbelt if the tractor has a ROPS.
2. Where possible, avoid operating the tractor near steep ditches, embankments, and holes.
3. Reduce speed when turning, crossing slopes, and on rough, slick, or muddy surfaces.
4. Stay off slopes too steep for safe operation.
5. Watch where you are going – especially at row ends, on roads, and around trees.
6. Do Not permit others to ride.
7. Operate the tractor smoothly – no jerky turns, starts, or stops.
8. Hitch only to the draw-bar and hitch points recommended by the tractor manufacturer.
9. When the tractor is stopped, set brakes securely and use park lock, if available



Printed in USA
© Tiger Corporation